

Metal Bellows Coupling

with collet clamps

optional
laserwelded
optional full stainless
steel version

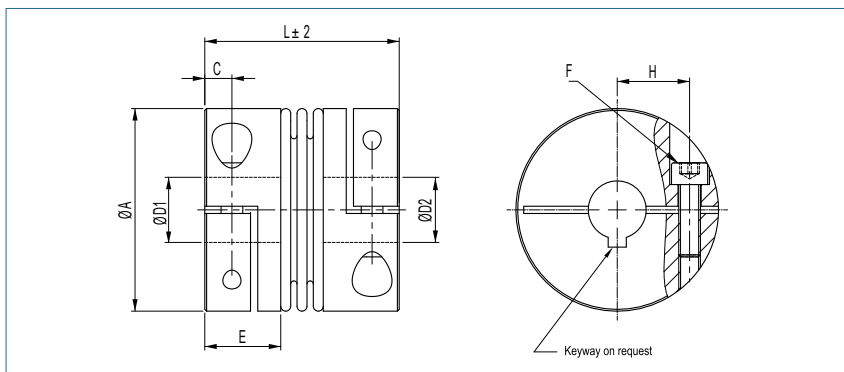

Order Code

KB4K / 400 - 75 - 44 - 40 - (S)

Type / Size

Length
L

ØD1
(H7)

ØD2
(H7)

Options

Size	Torque TKN (Nm)	Dimensions (mm)							Technical Data								
		L	Ø A	D1/D2	H	C	E	F	Mass (kg)	Moment of Inertia J (g m ²)	Spring Stiffness			Misalignment			max speed (min ⁻¹)
		Length	Outer Ø	Bore Sizes (H7) min-max				Screw (ISO4762) TA (Nm)			torsional CT 10 ³ (Nm/rad)	radial CR (N/mm)	axial CA (N/mm)	radial ΔKr (mm)	axial ΔKa (mm)	angular ΔKw (°)	
40	40	46	45	10-25.4	17	5.5	17.5	M5 8	0.07	0.04	3	3350	97	0.05	0.5	0.5	12800
80	80	55	56	12-32 30#	20	7.3	21	M6 15	0.26	0.14	11	6436	165	0.05	0.5	0.5	10300
200	200	60	66	16-35	23	8.6	23	M8 40	0.38	0.28	40	12442	287	0.1	1	0.5	8700
400	400	75	82	32-44	28	9.8	27	M10 84	0.70	0.82	76	6815	338	0.1	1	0.5	6900
650	650	78	90	37-47	39	10.8	29	M12 125	0.89	1.19	103	7910	386	0.1	1.5	1	6400
1000	1000	89	110	42-60	39	11.8	32,5	M12 145	1.37	2.74	1252	29096	756	0.1	1.5	1	6000
1500	1500	96	122	50-70	45	13.3	36	M12 145	1.81	4.45	693	20694	639	0.1	1.5	1	5000



Material	bellows - stainless steel hub - aluminium
Hub	bore tolerance: H7
Temperature Range	-30 °C ~ 120 °C
Keyway	optional acc. DIN 6885 biggest bore marked with a #