

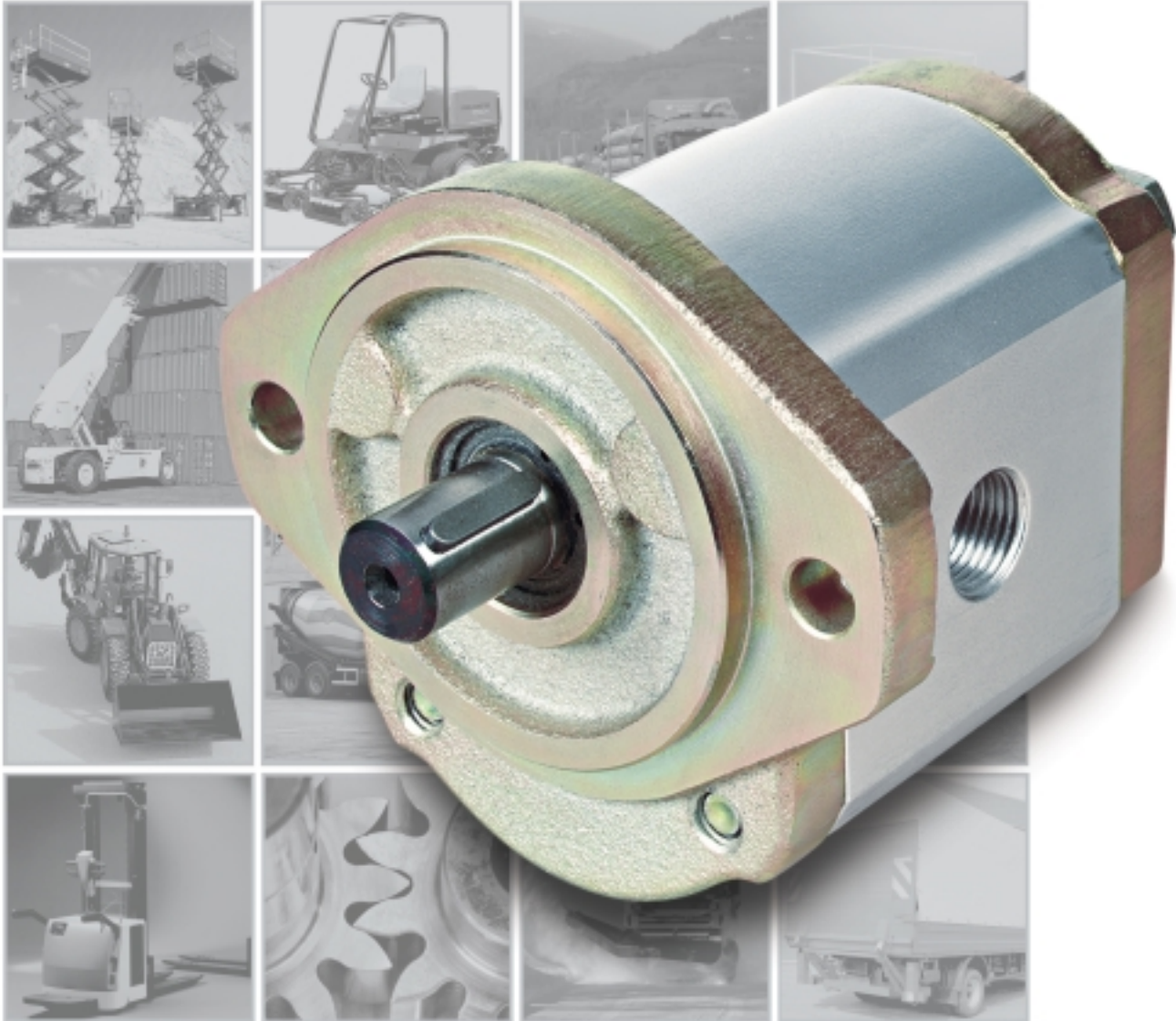

HIGH PRESSURE GEAR PUMP W900





THE POWER OF THE W900 A SERIES _____

Haldex Hydraulics is one of the world's leading manufacturers of hydraulic pumps. In recent years we have focused on important markets, such as materials handling and vehicles, and now the result are in: a series of high-performance hydraulic pumps. The W900 series builds on the versatile technical platform represented by the W series.

W900 High Pressure Gear Pumps are optimized for demanding work, with harsh weather conditions, rugged operations and long service intervals. The W900 series is a range of cost-efficient group II pumps for all applications in which the customer's demands for quality and reliability are particularly high.



_____ **FLANGE CODE 03, 06, 07, 10, 11, 12, 13** _____

4 - 9

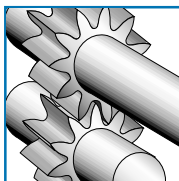

_____ **EFFICIENCIES** _____

10 - 11

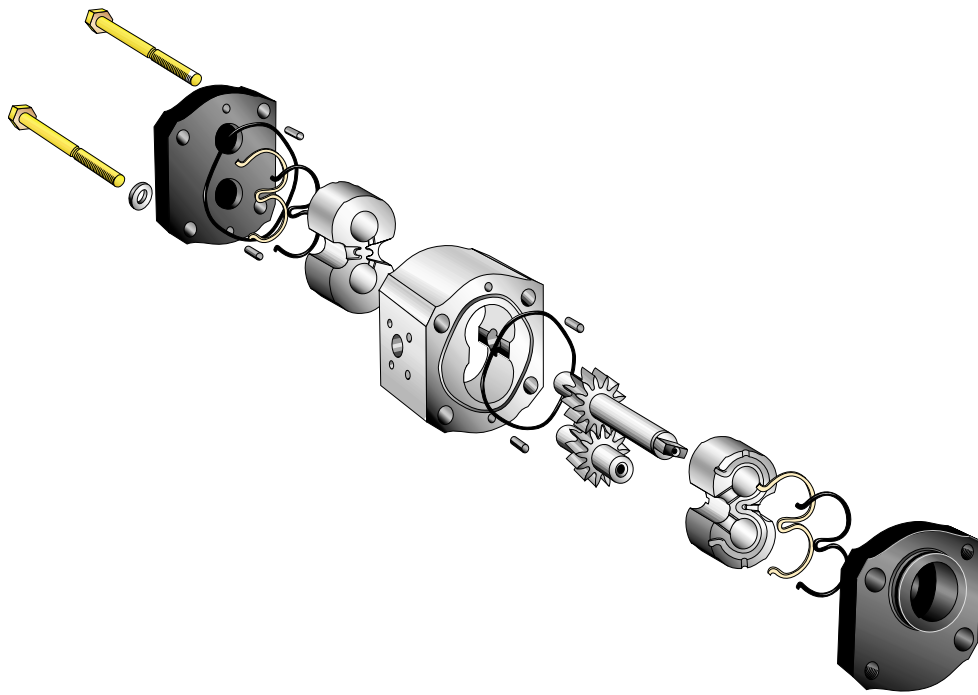

Model code example for a single pump

WP 09 A 1 B 050 R 03 BA 150 N
 ① ② ③ ④ ⑤ ⑥ ⑦ ⑧ ⑨ ⑩ ⑪

- | | |
|------------------------------|---------------------|
| ① = Type | ⑦ = Rotation |
| ② = Series | ⑧ = Mounting flange |
| ③ = Design revision | ⑨ = Drive shaft |
| ④ = # of sections | ⑩ = Portings |
| ⑤ = Seal material | ⑪ = Valve options |
| ⑥ = Displacement per section | |

W900 DESCRIPTION

The W900 pumps are available in a single or multiple configuration of up to four sections. The basic pump is of a three piece modular design. Mounting flange and rear cover are of cast iron. The pump body is manufactured from high strength aluminium alloy.

For optimum strength, gears and shafts are precision machined in one piece. The 13-tooth gear geometry has been optimized for low noise level.

All shaft bearing surfaces are Teflon® coated and designed for long service life. They are continually cooled and lubricated by a controlled flow of fresh oil. This enables operation across a wide speed range at very high loads.

Multiple pumps in the W900 range are very compact. The drive shaft is capable of transmitting high torque even to the rear section. Each section has its own inlet and pressure ports. Single inlet features are optional for 2 and 3 section unit.

A wide range of mounting flanges and port sizes are available to meet international standards.

General data

Displacement V	5 - 31cc/rev
Speed n	500 - 4000 rpm
Pressure rated pressure p_r	up to 276 bar
intermittent pressure p_{ii}	up to 300 bar
Operating temperatures t	up to 105° C
Average volumetric efficiency	97%

The maximum values for n , p_r and t for a given pump specification may be applied simultaneously.

Options

- SAE mounting flange, through bolt model.
- Rectangular flanges.
- Splined, tapered or straight shaft with key, tang shaft.
- Thread ports of flange ports.
- Clockwise or anti-clockwise rotation.
- Integrated valve features.
- Single inlet for multiple units.

PERFORMANCE DATA

Operating pressure range

Inlet port: continuous, minimum -0,20 bar
 intermittent, minimum -0,35 bar
 maximum +2,00 bar

Outlet port (See tables on pages 4-9)

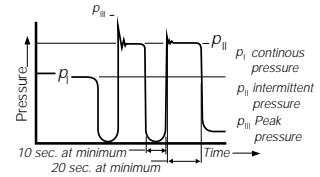

Product has been tested to 1,000,000 cycles at p_r . Pressure p_r is permitted at maxi. 20 sec loaded following 10 sec minimum unloaded.

Product has been tested to 500,000 cycles at p_{ii} . Above represents performance which can be expected from units incorporating flange port styles.

Speed range

Minimum speed for all pump sizes is $n=500$ rpm at maximum pressure p_r .

Maximum speed for single pumps depends on the pump model in question and can be identified from tables on pages 4-9 for respective models.

Maximum speed for multiple pumps is the lowest one specified (See tables on pages 4-9) for any section of the configuration in question.

Noise performance data according to DIN 45 635.

Typical levels at 200 bar and 2300 rpm using mineral oil with viscosity of 40 mm²/s and at temperature of 50° C:

W9A1-08	W9A1-16	W9A1-23
60 dB(A)	65 dB(A)	68 dB(A)

Hydraulic fluids. The use of HL-or HLP-hydraulic oil according to DIN 51 524 is recommended.

The permissible viscosity for all W900 pumps ranges from 750 to 10 mm²/s. The recommended operating viscosity range is from 40 to 16 mm²/s.

The permissible cold start viscosity is 2000 mm²/s.

We recommend to contact Haldex Barnes before using fire resistant or bio-degradable fluids.

Temperature range

Amb. temperature mini. -25° C
 maxi. +80° C

Fluid temperature continuous operation maxi. +90° C
 short term operation maxi. +105° C

Please note

Viscosities -when operating at above temperature limits-have to remain within the range specified under "Hydraulic Fluids".

Fluid cleanliness

Fluid cleanliness according to ISO 4406/1986 code 18/14 or better is required in order to assure the pump's high level of efficiency in the long term.

Drive arrangement

Flexible couplings are preferred for direct drives. Please contact Haldex Hydraulics for indirect drive requirements. Pumps with outboard side load bearing are available.

Mounting position

As required.

Symbols

Single pump
 Double pump
 Triple pump
 Quadruple pump

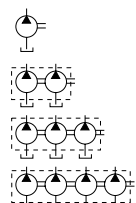

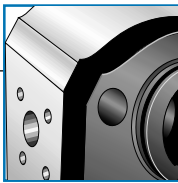

FLANGE CODE 03 (SAE A 2 BOLT)

All shaft bearings are continually cooled and lubricated by a controlled flow of fresh oil. This enables operation across a wide speed range at very high loads. The large sized side bearings support the pump's long-life condition. A wide range of mounting flanges and

port sizes are available to meet European and international standards. W900 pumps may also be supplied with threaded ports in the rear cover (Rear cover's shape is prepared for this option). This option can simplify installation where space is limited.

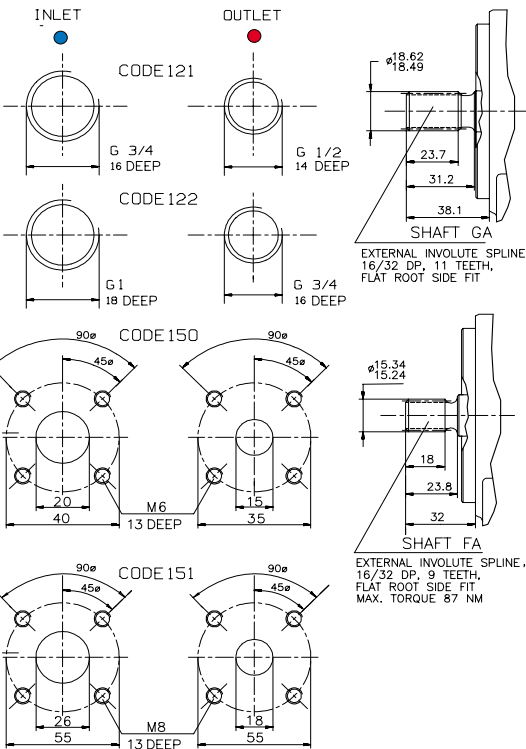
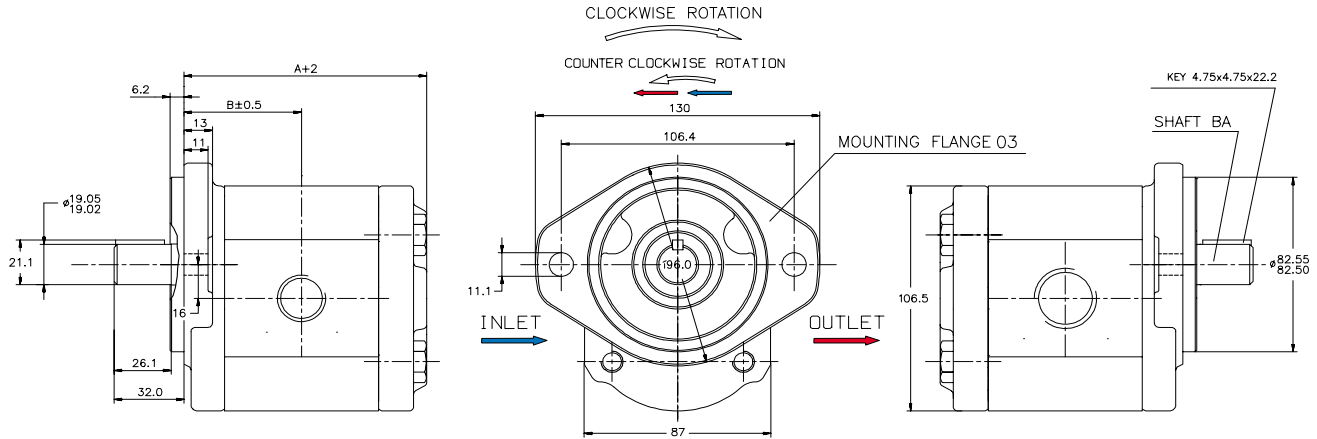

Model code example for a single pump

WP 09 A 1 B 050 R 03 BA 150 N
 ① ② ③ ④ ⑤ ⑥ ⑦ ⑧ ⑨ ⑩ ⑪

- ① = Type WP - Pump
- ② = Series 09 - 900
- ③ = Design revision A
- ④ = # of sections 1 - Single
2 - Duplex
3 - Triplex
4 - Quadruplex
- ⑤ = Seal material B - Buna
- ⑥ = Displacement per section (See Code Displ. below)
- ⑦ = Rotation
R - Clockwise
L - Counter clockwise
- ⑧ = Mounting flange
03 SAE A 2-Bolt
- ⑨ = Drive shaft
BA SAE A Key Ø 0,75"
GA SAE A Spline 11-t
FA SAE A Spline 9-t
- ⑩ = Portings
121 - G3/4" + G1/2" BSPP
122 - G1" + G3/4" BSPP
150 - 20 mm + 15 mm 4-b flange
151 - 26 mm + 18 mm 4-b flange
- ⑪ = Valve options N - None

Size	Rated pressure (bar)		Maximum speed (rpm)		Dimensions		Weight (approx.) [kg]
	Shaft c. 'BA'/'GA'	Shaft c. 'FA'	Port. c. '121'/'150'	Port. c. '122'/'151'	A [mm]	B [mm]	
050 - 5,0cc	276	276	4000	-	90,1	43,3	3,7
060 - 6,0cc	276	276	4000	-	91,6	44,0	3,8
080 - 8,0cc	276	276	4000	-	94,6	45,5	3,9
110 - 11,0cc	276	276	3600	-	99,0	47,7	4,1
140 - 14,0cc	276	276	3300	-	103,5	50,0	4,2
160 - 16,0cc	276	276	3000	-	106,4	51,4	4,3
190 - 19,0cc	276	265	3000	-	110,9	53,7	4,4
230 - 23,0cc	221	221	2800	3500	116,8	56,6	4,6
270 - 27,0cc	185	185	-	3000	122,7	59,6	4,8
310 - 31,0cc	170	165	-	2500	128,7	62,6	5,0



FLANGE CODE 06

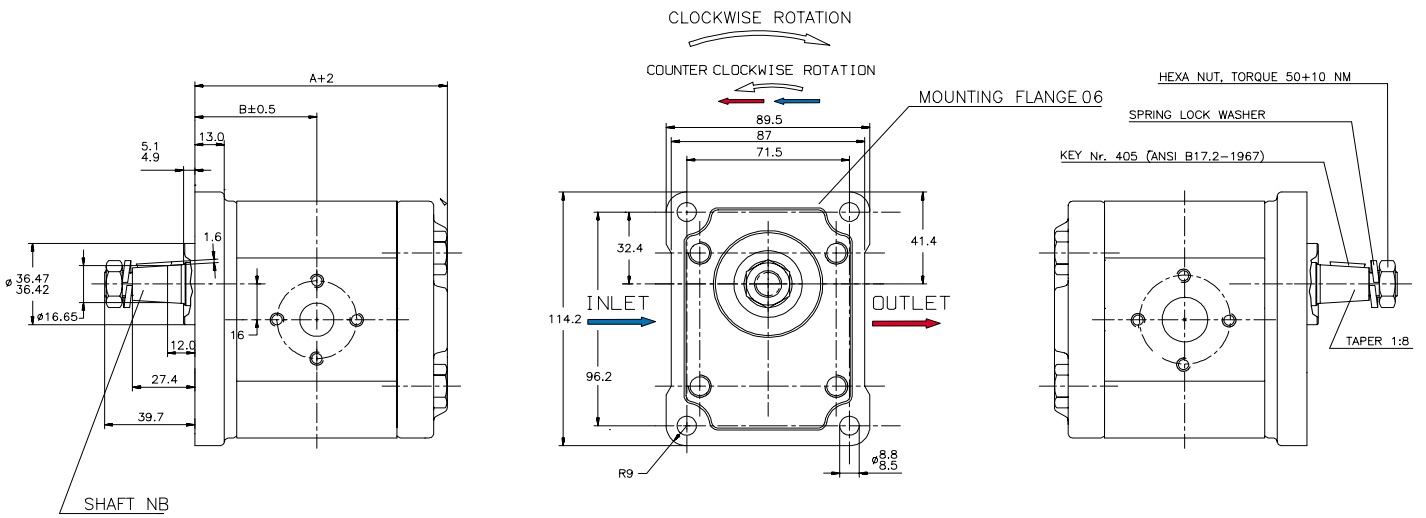

Model code example for a single pump

WP 09 A 1 B 050 R 06 NB 160 N
 ① ② ③ ④ ⑤ ⑥ ⑦ ⑧ ⑨ ⑩ ⑪

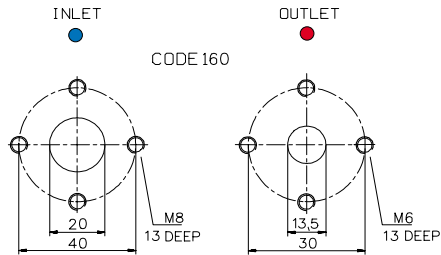

For pump displacement 050-080

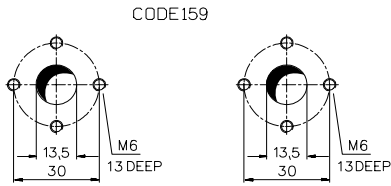

- ① = Type WP - Pump
- ② = Series 09 - 900
- ③ = Design revision A
- ④ = # of sections
1 - Single
2 - Duplex
3 - Triplex
4 - Quadruplex
- ⑤ = Seal material B - Buna
- ⑥ = Displacement per section
(See Code Displ. below)
- ⑦ = Rotation
R - Clockwise
L - Counter clockwise
- ⑧ = Mounting flange
06 Rect. Ø 36,5 mm pilot
- ⑨ = Drive shaft
NB European Tapered shaft 1:8
- ⑩ = Portings
160 - 20 mm + 13,5 mm
- ⑪ = Valve options N - None

Size	Rated pressure (bar)	Maximum speed (rpm) Port. c. '160'	Dimensions		Weight (approx.) [kg]
			A [mm]	B [mm]	
050 - 5,0cc	276	4000	90,1	43,3	3,7
060 - 6,0cc	276	4000	91,6	44,0	3,8
080 - 8,0cc	276	4000	94,6	45,5	3,9
110 - 11,0cc	276	3600	99,0	47,7	4,1
140 - 14,0cc	276	3300	103,5	50,0	4,2
160 - 16,0cc	276	3000	106,4	51,4	4,3
190 - 19,0cc	276	3000	110,9	53,7	4,4
230 - 23,0cc	221	2800	116,8	56,6	4,4
270 - 27,0cc	185	2350	122,7	59,6	4,8
310 - 31,0cc	170	1900	128,7	62,6	5,0

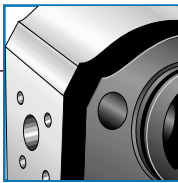

FLANGE CODE 07

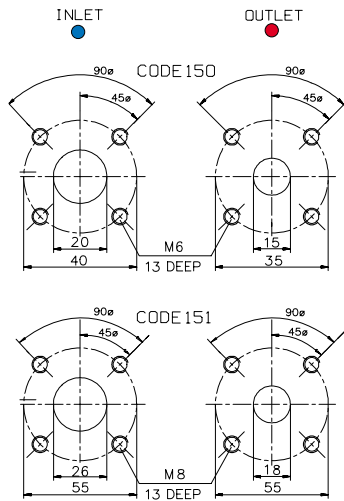
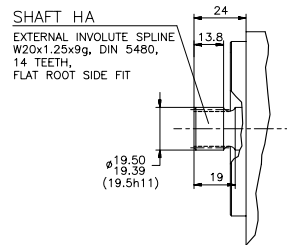
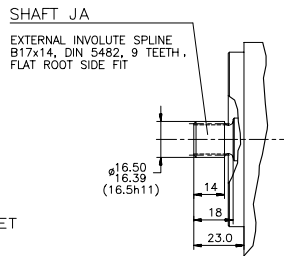
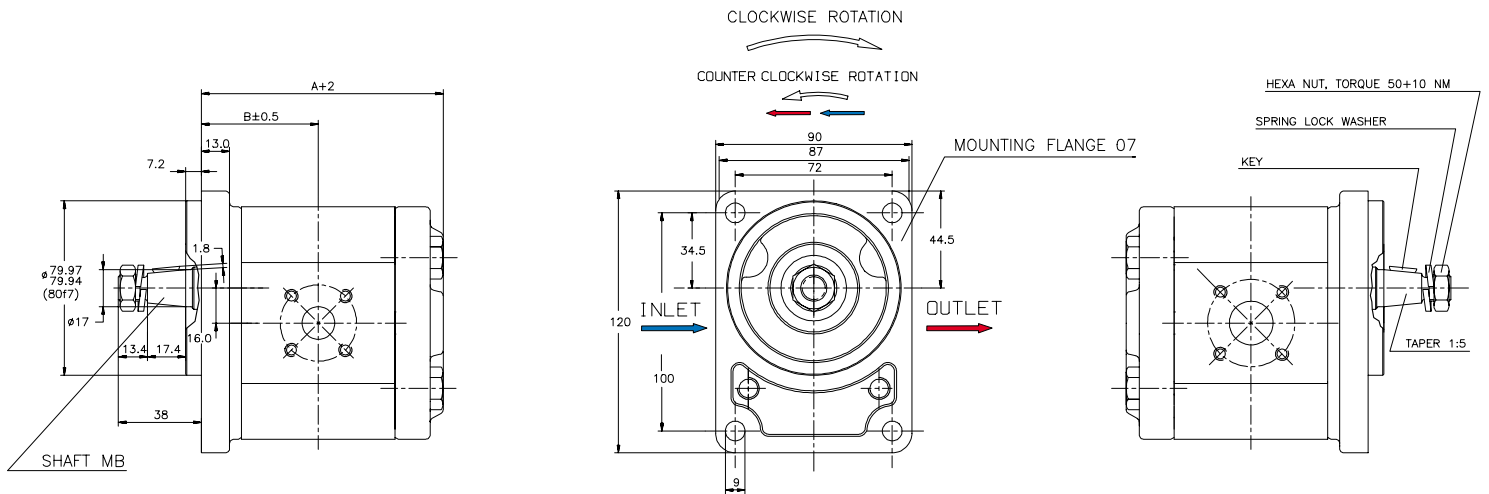

Model code example for a single pump

WP 09 A 1 B 060 R 07 MB 150 N
 ① ② ③ ④ ⑤ ⑥ ⑦ ⑧ ⑨ ⑩ ⑪

- ① = Type WP - Pump
- ② = Series 09 - 900
- ③ = Design revision A
- ④ = # of sections
1 - Single
2 - Duplex
3 - Triplex
4 - Quadruplex
- ⑤ = Seal material B - Buna
- ⑥ = Displacement per section
(See table below)
- ⑦ = Rotation
R - Clockwise
L - Counter clockwise
- ⑧ = Mounting flange
07 Rect. Ø 80 mm pilot
- ⑨ = Drive shaft
MB European Tapered shaft 1:5
JA DIN 5482 Spline 9-t
HA DIN 5480 Spline 14-t
- ⑩ = Portings
150 - 20 mm + 15 mm 4-b flange
151 - 26 mm + 18 mm 4-b flange
- ⑪ = Valve options N - None

Size	Rated pressure (bar)	Maximum speed (rpm)		Dimensions		Weight (approx.) [kg]
		Port. c. '150'	Port. c. '151'	A [mm]	B [mm]	
050 - 0,5cc	276	4000	-	90,1	43,3	3,7
060 - 6,0cc	276	4000	-	91,6	44,0	3,8
080 - 8,0cc	276	4000	-	94,6	45,5	3,9
110 - 11,0cc	276	3600	-	99,0	47,7	4,1
140 - 14,0cc	276	3300	-	103,5	50,0	4,2
160 - 16,0cc	276	3000	-	106,4	51,4	4,3
190 - 19,0cc	276	3000	-	110,9	53,7	4,4
230 - 23,0cc	221	2800	3500	116,8	56,6	4,4
270 - 27,0cc	185	-	3000	122,7	59,6	4,8
310 - 31,0cc	170	-	2500	128,7	62,6	5,0

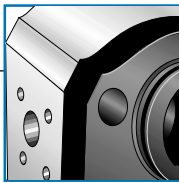

FLANGE CODE 10 OR CODE 11 (THROUGH BOLT Ø50 mm PILOT)

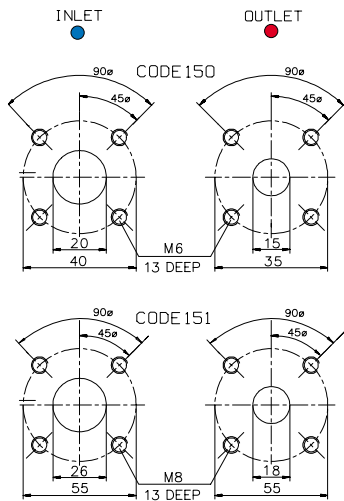
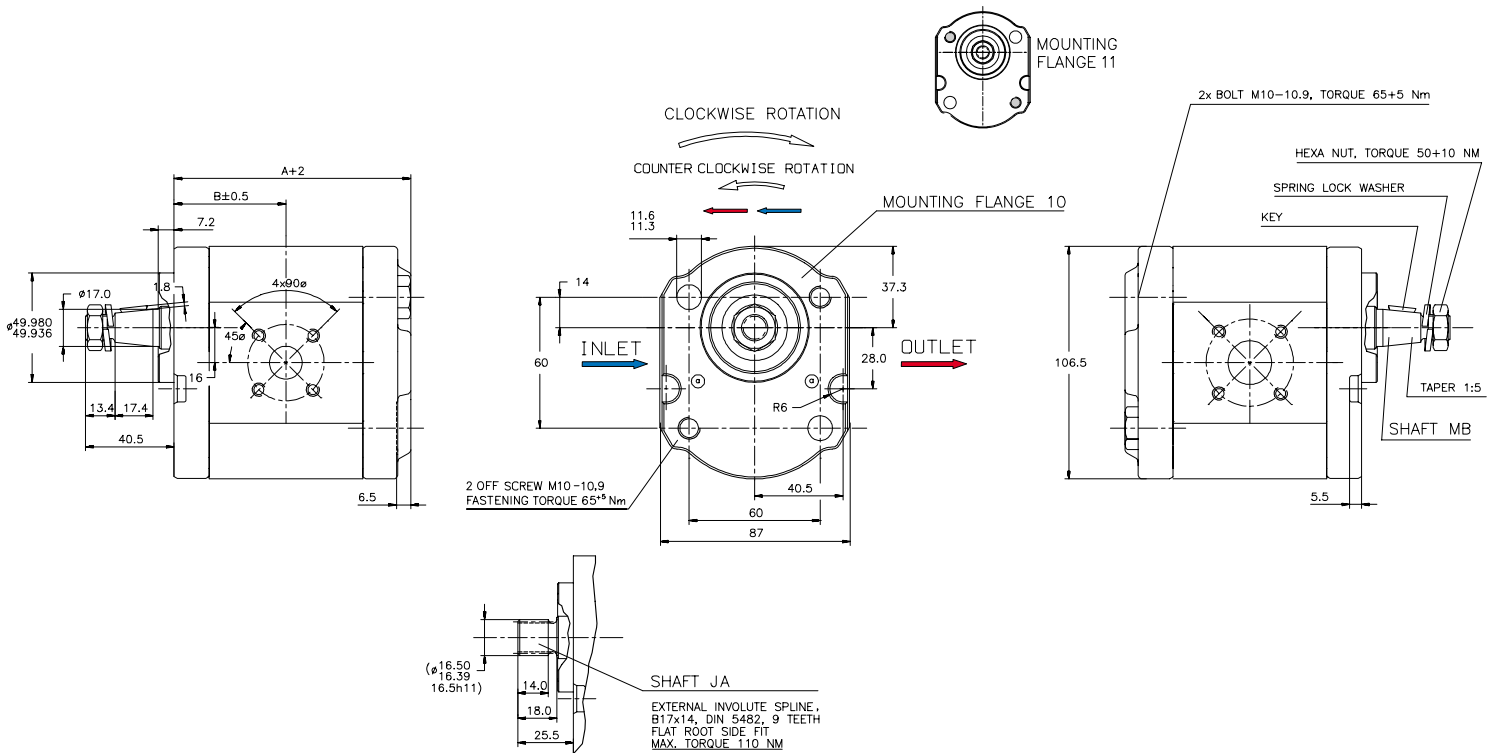

Model code example for a single pump

WP 09 A 1 B 060 R 10 MB 150 N
 ① ② ③ ④ ⑤ ⑥ ⑦ ⑧ ⑨ ⑩ ⑪

- ① = Type WP - Pump
- ② = Series 09 - 900
- ③ = Design revision A
- ④ = # of sections
 1 - Single
 2 - Duplex
 3 - Triplex
 4 - Quadruple
- ⑤ = Seal material B - Buna
- ⑥ = Displacement per section
 (See table below)
- ⑦ = Rotation
 R - Clockwise
 L - Counter clockwise
- ⑧ = Mounting flange
 10 Through-bolt Ø 50 mm pilot
 11 Through-bolt Ø 50 mm pilot
- ⑨ = Drive shaft
 MB European Tapered shaft 1:5
 JA DIN 5482 Spline 9-t
- ⑩ = Portings
 150 - 20 mm + 15 mm 4-b flange
 151 - 26 mm + 18 mm 4-b flange
- ⑪ = Valve options N - None

Size	Rated pressure (bar)	Maximum speed (rpm)		Dimensions		Weight (approx.) [kg]
		Port. c. '150'	Port. c. '151'	A [mm]	B [mm]	
050 - 5,0cc	276	4000	-	87,6	40,8	3,7
060 - 6,0cc	276	4000	-	89,1	41,5	3,8
080 - 8,0cc	276	4000	-	92,1	43,0	3,9
110 - 11,0cc	276	3600	-	96,5	45,2	4,1
140 - 14,0cc	276	3300	-	101,0	47,5	4,2
160 - 16,0cc	276	3000	-	103,9	48,9	4,3
190 - 19,0cc	276	3000	-	108,4	51,2	4,4
230 - 23,0cc	221	2800	3500	114,3	54,1	4,6
270 - 27,0cc	185	-	3000	120,2	57,1	4,8
310 - 31,0cc	170	-	2500	126,2	60,1	5,0



FLANGE CODE 12 OR CODE 13 - WITHOUT SHAFT SEAL (THROUGH BOLT Ø52 mm PILOT)

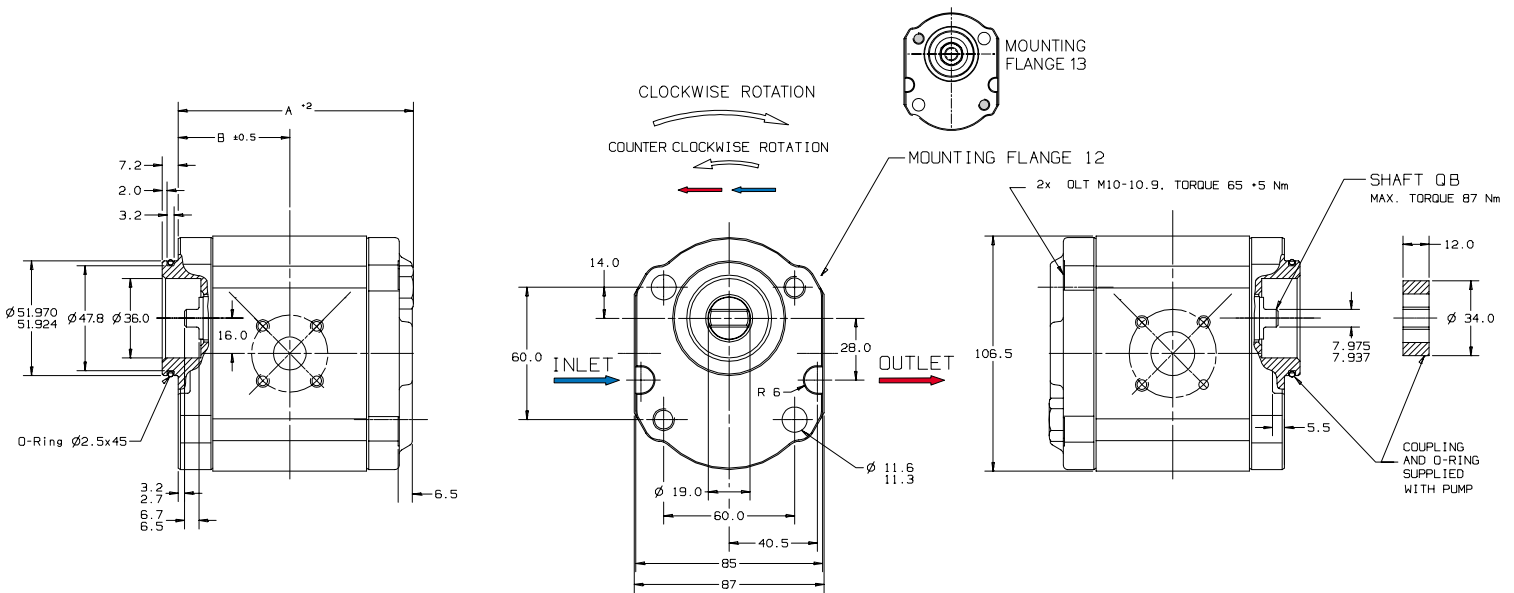

INLET OUTLET

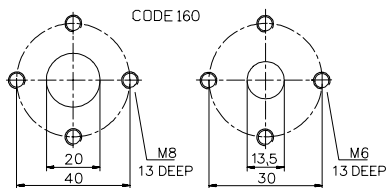
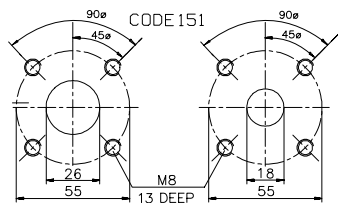
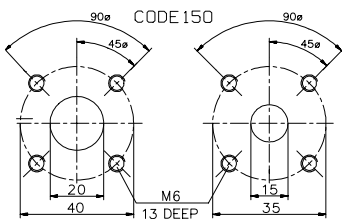

Model code example for a single pump

WP 09 A 1 B 060 R 12 QB 150 N
 ① ② ③ ④ ⑤ ⑥ ⑦ ⑧ ⑨ ⑩ ⑪

- ① = Type WP - Pump
- ② = Series 09 - 900
- ③ = Design revision A
- ④ = # of sections 1 - Single
2 - Duplex
3 - Triplex
4 - Quadruple
- ⑤ = Seal material B - Buna
- ⑥ = Displacement per section (See table below)
- ⑦ = Rotation
R - Clockwise
L - Counter clockwise
- ⑧ = Mounting flange
12 Through-bolt Ø 52 mm pilot
13 Same as 12 but opposite bolt pattern
- ⑨ = Drive shaft
QB Wet Tang
- ⑩ = Portings
150 - 20 mm + 15 mm 4-b flange
151 - 26 mm + 18 mm 4-b flange
160 - 20 mm + 13,5 mm 4-b flange
- ⑪ = Valve options N - None

Size	Rated pressure (bar) Shaft 'QB'	Maximum speed (rpm)		Dimensions		Weight (approx.) [kg]
		Port. '150'/'160'	Port. '151'	A [mm]	B [mm]	
050 - 0,5cc	276	4000	-	87,6	40,8	3,7
060 - 0,6cc	276	4000	-	89,1	41,5	3,8
080 - 0,8cc	276	4000	-	92,1	43,0	3,9
110 - 11,0cc	276	3600	-	96,5	45,2	4,1
140 - 14,0cc	276	3300	-	101,0	47,5	4,2
160 - 16,0cc	276	3000	-	103,9	48,9	4,3
190 - 19,0cc	265	3000	-	108,4	51,2	4,4
230 - 23,0cc	221	2800	3500	114,3	54,1	4,6
270 - 27,0cc	185	-	3000	120,2	57,1	4,8
310 - 31,0cc	160	-	2500	126,2	60,1	5,0

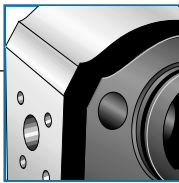

REAR PORT

Rear port end cover can be combined with all flange and shaft options. All technical data from the preceding pages apply to this model.

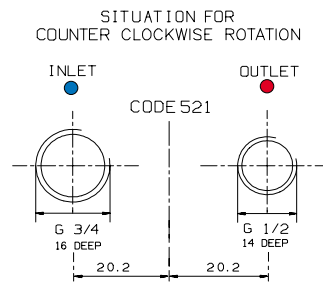
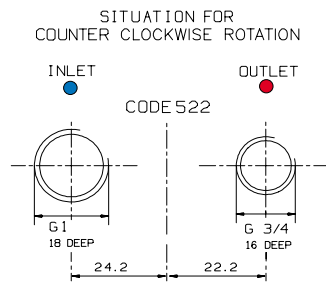
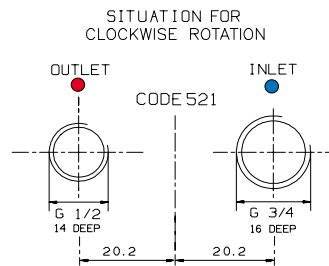
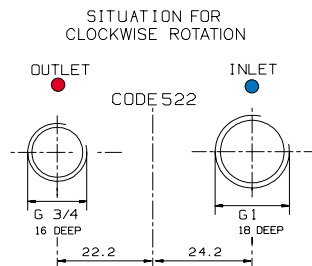
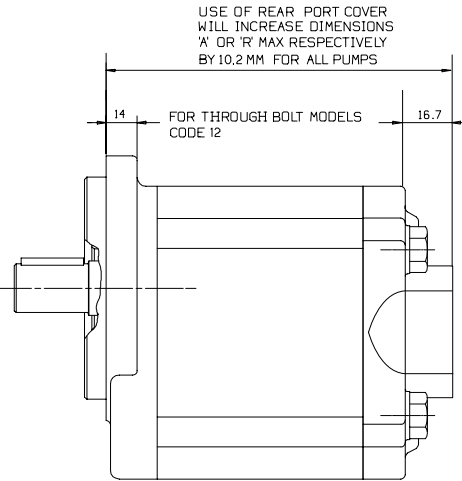
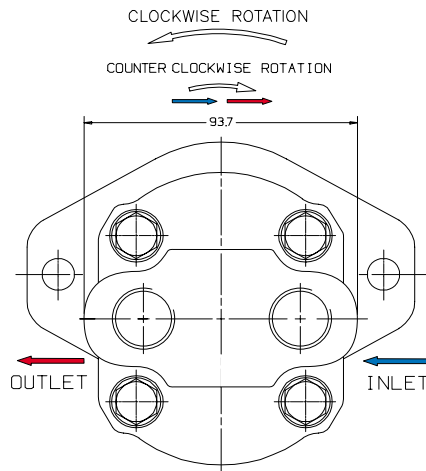

Size	Rated pressure (bar)	Maximum speed (rpm)		Weight (approx.) [kg]
		Port. '521'	Port. '522'	
WP09AX				
050 - 5,0cc		4000	-	3,7
060 - 6,0cc		4000	-	3,8
080 - 8,0cc	can be taken from Tables on pages 4-8	4000	-	3,9
110 - 11,0cc		3600	-	4,1
140 - 14,0cc		3300	-	4,2
160 - 16,0cc		3000	-	4,3
190 - 19,0cc		3000	-	4,4
230 - 23,0cc		2800	3500	4,6
270 - 27,0cc		-	3000	4,8
310 - 31,0cc		-	2500	5,0

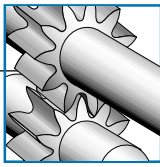

MULTIPLE PUMPS

The two following parameters are of the utmost importance when selecting multiple pumps and must never be exceeded:

- Drive shaft load index "A"
- Internal coupling load index "K"

Maxi. load index K 5240

for double pump

$$K = (p_2 \times V_2)$$

for triple pump

$$K = (p_2 \times V_2) + (p_3 \times V_3)$$

for quadruple pump

$$K = (p_2 \times V_2) + (p_3 \times V_3) + (p_4 \times V_4)$$

Maximum drive shaft load index "A", see table below

for double pump

$$A = (p_1 \times V_1) + (p_2 \times V_2)$$

for triple pump

$$A = (p_1 \times V_1) + (p_2 \times V_2) + (p_3 \times V_3)$$

for quadruple pump

$$A = (p_1 \times V_1) + (p_2 \times V_2) + (p_3 \times V_3) + (p_4 \times V_4)$$

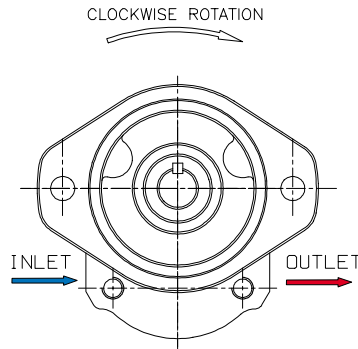
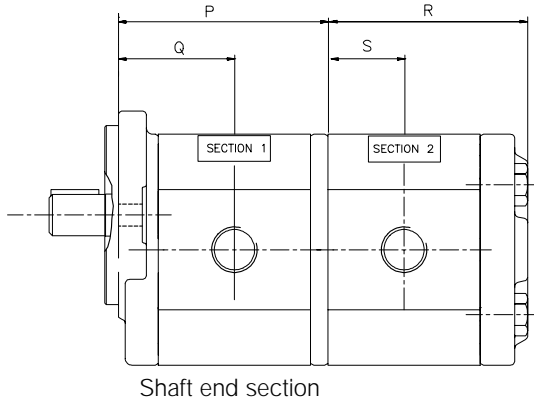

Drive shaft	Load index A	Drive shaft	Load index A
BA	10488	JA	6215
FA	5100	MB	10488
GA	9608	NB	10488
HA	11304	QB	5012

Note: P = actual pressure in bar,
V = applicable displacement from table page 4-8.

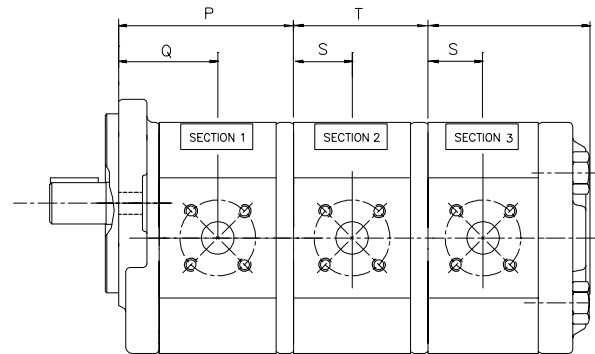

In multiple pumps, shaft end section must have largest displacement. Each consecutive section must have displacement equal to or smaller than section proceeding.

Haldex Hydraulics multiple pumps are also available with reduced number of inlets. Please contact Haldex Hydraulics for details. Please, contact Haldex Hydraulics for pump applications requiring independently sealed sections.

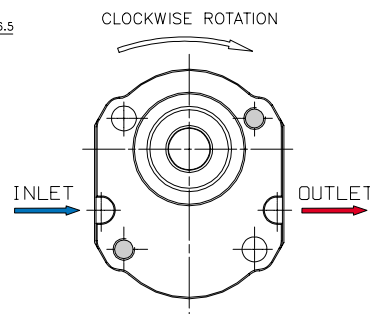
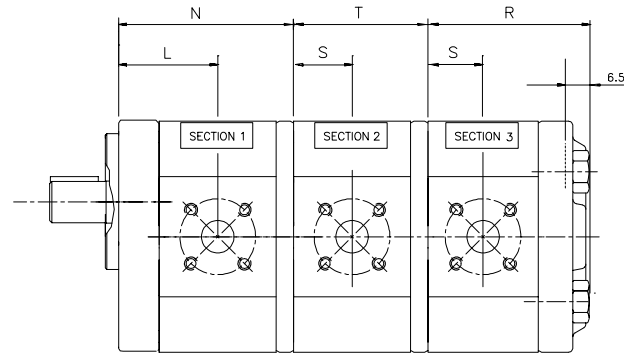

Size	P	Q	Weight	R	S	Weight	T	Weight	N	L	Weight
	mm	mm	kg	mm	mm	kg	mm	kg	mm	mm	kg
	Shaft end section			Rear section			2nd & 3rd section		A1-section		
060 - 0,6cc	77,6	44,0	3,1	73,4	25,6	2,7	59,1	1,8	75,1	41,5	2,7
080 - 0,8cc	80,0	45,5	3,2	76,4	27,0	2,8	62,1	1,9	78,1	41,5	2,7
110 - 11,0cc	85,0	47,7	3,4	80,8	29,2	3,0	66,5	2,1	82,5	45,2	3,0
140 - 14,0cc	89,5	50,0	3,5	85,2	31,5	3,1	71,0	2,2	87,0	47,5	3,1
160 - 16,0cc	92,4	51,4	3,6	88,1	33,0	3,2	73,9	2,3	89,9	48,9	3,2
190 - 19,0cc	96,9	53,7	3,7	92,7	35,2	3,4	78,4	2,4	94,4	51,2	3,4
230 - 23,0cc	102,8	56,6	3,9	98,6	38,2	3,5	84,3	2,6	100,3	54,1	3,5
270 - 27,0cc	108,7	59,6	4,1	104,5	41,1	3,7	90,2	3,7	106,2	57,1	3,7
310 - 31,0cc	114,8	62,6	4,3	110,5	44,1	3,9	96,2	3,0	112,2	60,1	3,9

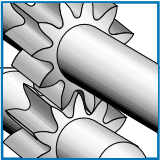

EFFICIENCIES, TOTAL, MECHANICAL, VOLUMETRIC

W9A1-06 (Average $\pm 3\%$ at 30 cSt)

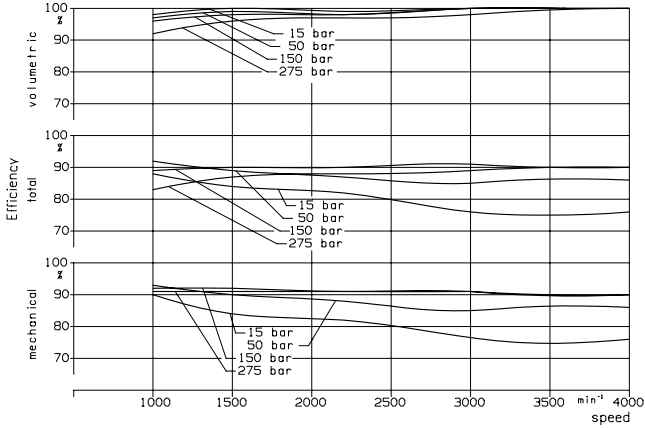

W9A1-16 (Average $\pm 3\%$ at 30 cSt)

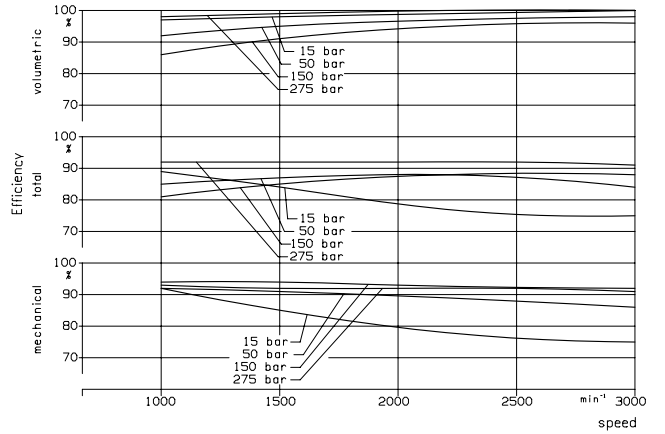

W9A1-08 (Average $\pm 3\%$ at 30 cSt)

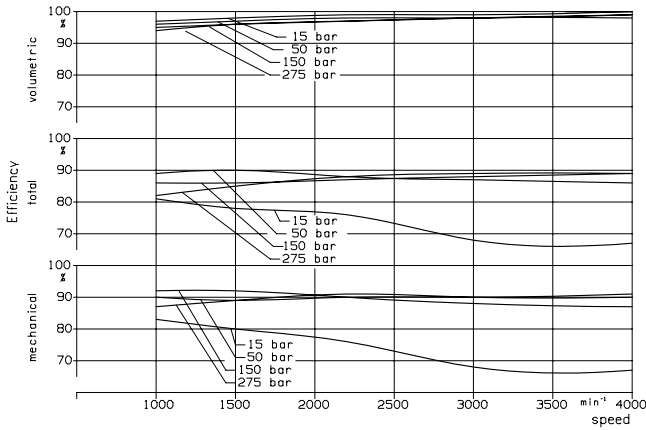

W9A1-19 (Average $\pm 3\%$ at 30 cSt)

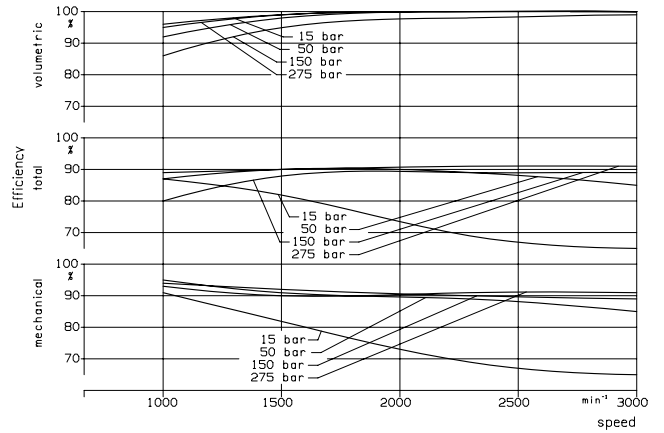

W9A1-11 (Average $\pm 3\%$ at 30 cSt)

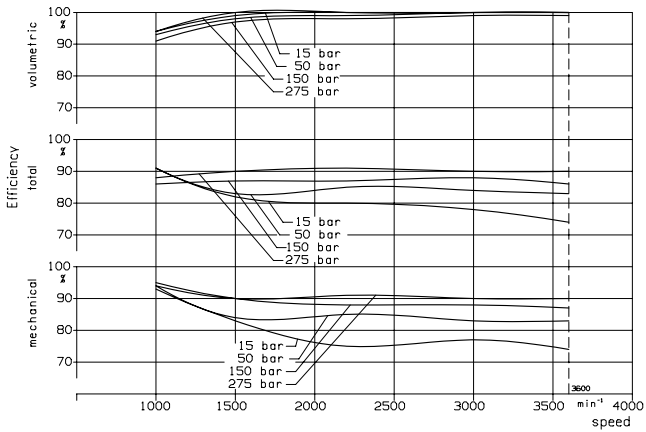

W9A1-23 (Average $\pm 3\%$ at 30 cSt)

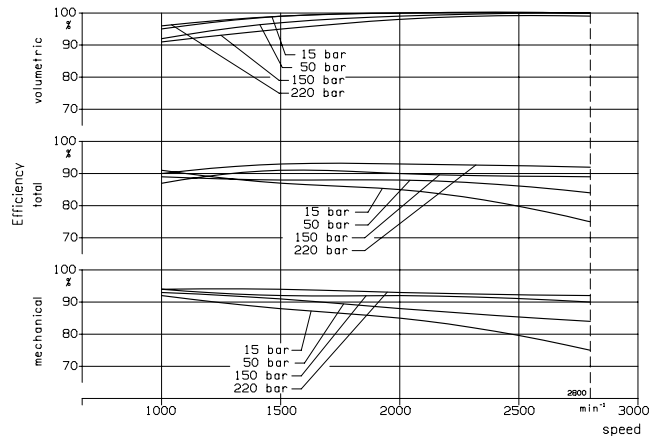

W9A1-14 (Average $\pm 3\%$ at 30 cSt)

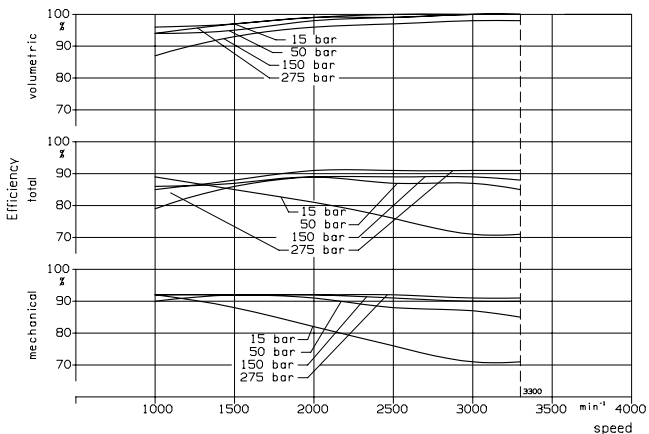

W9A1-27 (Average $\pm 3\%$ at 30 cSt)

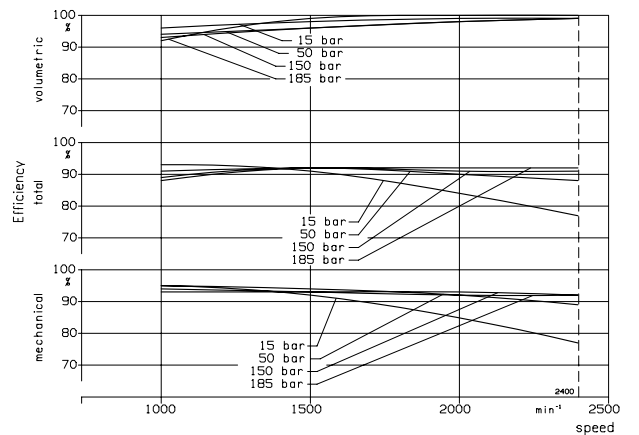

Haldex

HALDEX WP100 GB-03-03

www.haldex.com



Haldex Hydraulics AB
Industrigatan 6
Box 511
SE-195 25 ARLANDASTAD
Sweden
Tel: +46-8 591 288 50
Fax: +46-8 591 288 60
info.hydraulics.eu@haldex.com

Haldex Hydraulics AB
Ringvägen 3
SE-280 40 SK. FAGERHULT
Sweden
Tel: +46-433 32400
Fax: +46-433 30546
info.hydraulics.eu@haldex.com

Haldex Hydraulics GmbH
Seligenweg 12
Postfach 1507
DE-95014 HOF
Germany
Tel: +49-9281 895-0
Fax: +49-9281 87133
info.hydraulics.eu@haldex.com

Haldex Hydraulics Corp.
2222 15th Street
ROCKFORD, IL 61104
USA
Tel: +1-815 398 4400
Fax: +1-815 398 5977
info.hydraulics.us@haldex.com

Haldex Hydraulics Corp.
214 James Farm Road
Statesville, NC 28625
USA
Tel: +1-704 873 2587
Fax: +1-704 838 7989
info.hydraulics.us@haldex.com



Haldex is an innovator in vehicle technology and supplies proprietary systems and components for trucks, cars and industrial vehicles worldwide. Haldex is listed on the Stockholm Stock Exchange and has yearly sales exceeding 6,5 billion Swedish Krona with 4.000 employees (www.haldex.com).

PRODUCT RANGE

HE Powerpacks
12/24/48 VDC 0.3 – 4.5 kW and
0.75 – 3 kW AC modular power
packs

Pressure Switches
5 - 350 bar, connecting/
disconnecting

HE Box Powerpacks
12/24/48 VDC modular
powerpacks in weatherproof
boxes

W100 Hydraulic pumps
0,5 - 2,0 cc 227 bar

W300 Hydraulic pumps
0.8 – 5.7 cc 230 bar

W600 Hydraulic pumps
3 – 12 cc 276 bar

WM600 Hydraulic motors
3 – 12 cc 276 bar

W900 Hydraulic pumps
5 – 31 cc/section 276 bar

WM900 Hydraulic motors
5 - 31 cc/section 276 bar

WQ900 The quiet pump
5 - 23 cc/section 230 bar

W1500 Hydraulic pumps
19 - 50 cc/section 276 bar

WM1500 Hydraulic motors
19 - 50 cc/section 276 bar

G25 Hydraulic pumps
21.3 – 63 cc/section 250 bar

GPA Internal Gear pumps
1.7 – 63 cc/section 100 bar

GC Hydraulic pumps
1.06 – 11.65 cc/section 275 bar

II-Stage Hydraulic pumps
4.2 – 22.8 cc/section 275 bar

Rotary Flow Dividers
3.8 – 13.3 cc/section 300 bar

G20/G30 (LS) Hydraulic pumps
23 – 161 cc/section 275 bar

Transmission pumps

Fuel pumps