

# **G25** SERIES 20

## **BI-ROTATIONAL GEAR PUMPS**

---

**LOW NOISE, HIGH EFFICIENCIES  
CAST IRON CONSTRUCTION**

---

**Displacements from 23 cc (1.4 in.<sup>3</sup>)  
to 87 cc (5.3 in.<sup>3</sup>)**

**Pressures to 210 BAR (3045 PSI) Continuous**



**Haldex**

# Contents

<i>Description, features and benefits</i> .....	<i>2 &amp; 3</i>
<i>Specifications and application data</i> .....	<i>5</i>
<i>Model code - Single pumps</i> .....	<i>8</i>
<i>Installation dimensions - Single pumps</i> .....	<i>4</i>
<i>Options/dimensions -</i>	
<i>Port connections</i> .....	<i>7</i>
<i>Mounting flanges</i> .....	<i>5</i>
<i>Drive shafts</i> .....	<i>6</i>
<i>Sound level and performance data -</i>	
<i>Performance Curves</i> .....	<i>7</i>

## Description, features and benefits

### *Low Noise, High Efficiency*

Haldex Barnes G25 Series 20 gear pumps are designed for low noise, high efficiency bi-rotational operation. The 14-tooth gear provides lower pressure ripple which results in lower noise amplitude and low noise operation. Gear sides and shaft journals are ground to a fine finish to further reduce noise. The cast iron construction also contributes to noise reduction.

In addition, cast iron housings allow gear tips to generate their own run-in paths, creating minimum radial gear-tip clearance for high volumetric efficiency.

The G25 Series 20 utilizes a patented 1 piece urethane seal that provides bi-rotational pressure compensation. Two seal packs and two die cast aluminum floating wear plates are retained within the gear housing to minimize leakage across the end faces of the gears and to reduce wear. During startup, the seal packs mechanically preload the plates against the ends of the gears. The seal packs also establish the wear plate area exposed to system pressure, allowing axial pressure loading and balancing of the wear plates. As pressure increases, the wear plates progress toward the gear faces to reduce clearances and balance opposing axial forces. Running clearances are maintained small enough for minimum leakage across the faces, yet large enough to maintain the oil film required to minimize wear of mating surfaces.

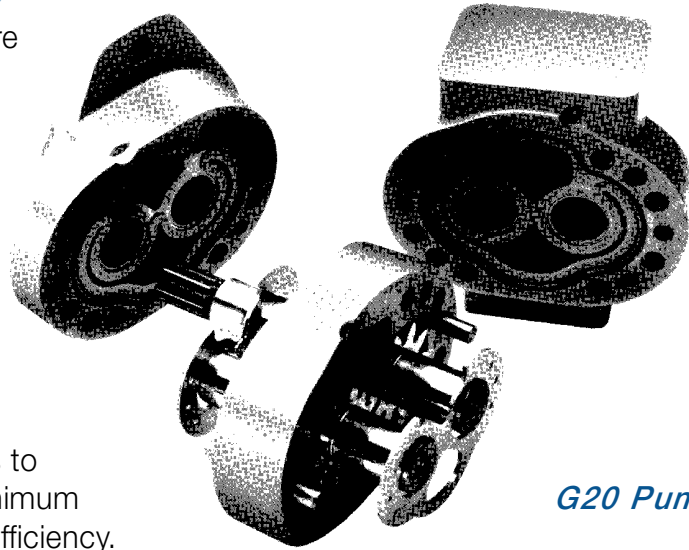

*G20 Pump*

## ***Heavy Duty Construction, Long Life***

Cast iron construction insures reliability and strength. The drive gear and drive shaft as well as the driven gear and shaft are one piece construction. This design eliminates the potential problems of fretting and stress fatigue associated with two piece construction. The one piece design also allows the use of large diameter journals and bearings for greater load carrying capability. The gears and shafts are of AISI 8620 alloy steel for greater shaft strength and a stronger gear assembly.

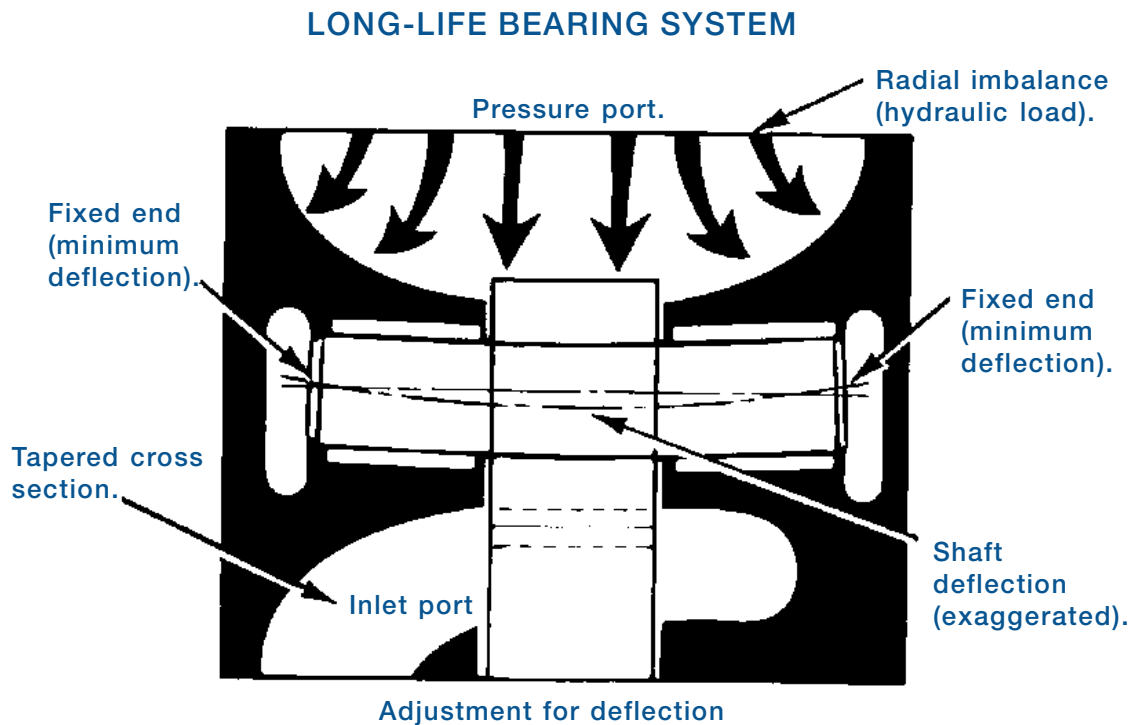

## ***Convenient, Economical Porting Arrangements***

G25 Series 20 pumps are available with side ports only, rear ports only or with both side & rear ports for total port location flexibility. A large selection of port sizes is charted in this catalog for your convenience.

## ***Choices of Mounting Flanges, Shafts and Seals***

Mounting Flanges and shafts meet SAE standards and are available in a number of sizes and types to satisfy various mounting requirements. Double shaft seals are ideal for applications where the pump pilot and shaft extend into a transmission case or crankcase. If either seal fails, the pump fluid remains separated from the transmission or crankcase fluid. This provides for a visual detection of seal malfunction.

# G25 Single Pump Installation Dimensions

Inches [mm]

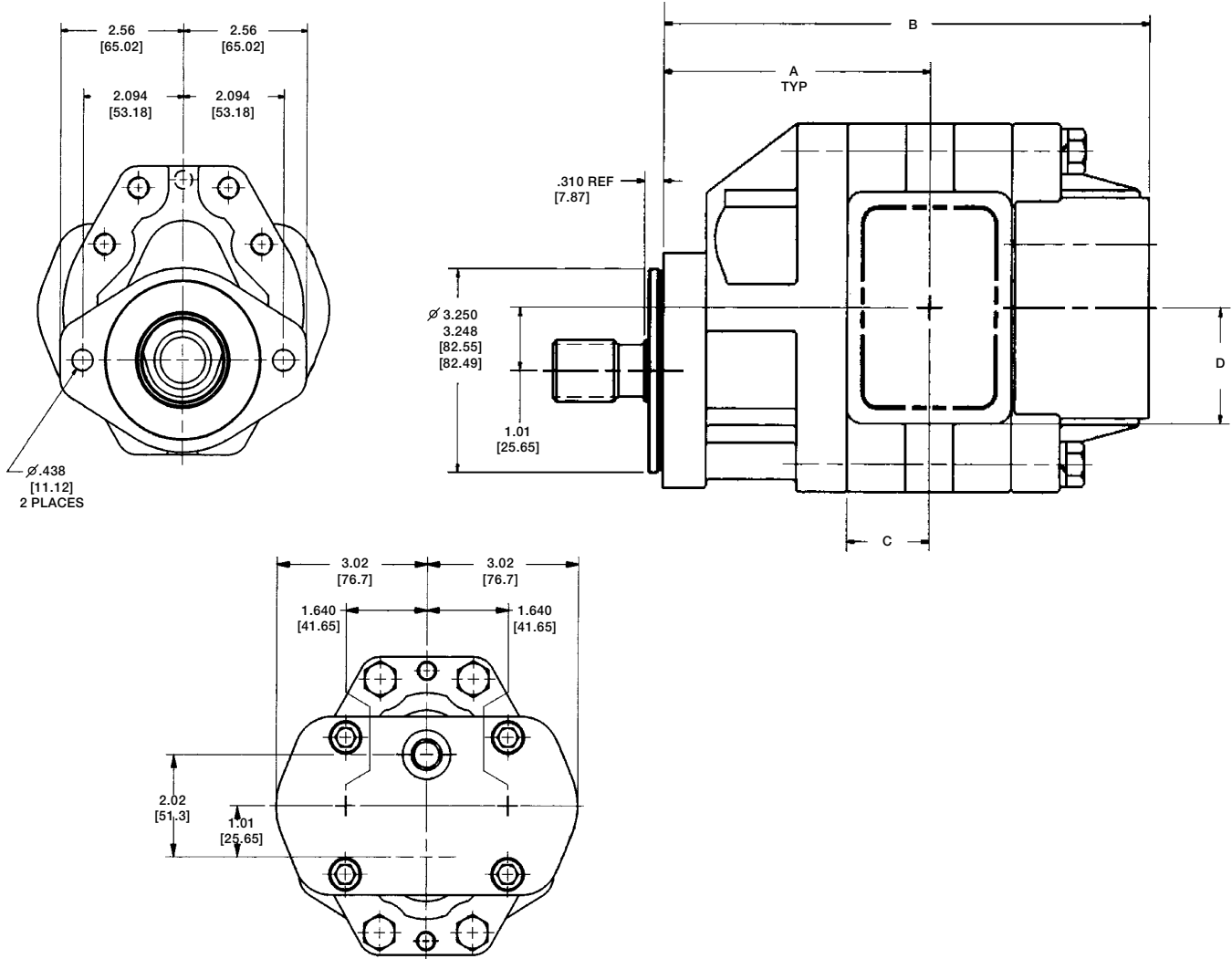

Model	"A" Inch (mm)	"B" Inch (mm)	"C" Inch (mm)	"D" Inch (mm)
G25-23-**-**-**F*F*-20-*	3.57 [90.8]	6.44 [163.5]	1.28 [32.5]	.62 [15.8]
G25-29-**-**-**F*F*-20-*	3.65 [92.8]	6.60 [167.6]	1.28 [32.5]	.70 [17.8]
G25-36-**-**-**F*F*-20-*	3.74 [94.9]	6.76 [177.8]	1.28 [32.5]	.78 [19.8]
G25-43-**-**-**F*F*-20-*	3.83 [97.2]	6.94 [176.3]	1.28 [32.5]	.87 [22.1]
G25-48-**-**-**F*F*-20-*	3.90 [99.0]	7.08 [180.0]	1.38 [35.0]	.94 [23.9]
G25-55-**-**-**F*F*-20-*	3.98 [101.1]	7.25 [184.2]	1.56 [39.6]	1.02 [25.9]
G25-62-**-**-**F*F*-20-*	4.07 [103.5]	7.44 [188.9]	1.56 [39.6]	1.17 [29.7]
G25-68-**-**-**F*F*-20-*	4.15 [105.4]	7.58 [192.7]	1.85 [47.0]	1.19 [30.2]
G25-77-**-**-**F*F*-20-*	4.27 [108.5]	7.83 [199.0]	1.85 [47.0]	1.32 [33.5]
G25-87-**-**-**F*F*-20-*	4.40 [111.7]	8.08 [205.3]	2.00 [50.8]	1.44 [36.6]

# Specifications and Application Data

Single pumps		Theoretical displacement per revolution		Rated pressure		Rated speed @ rated pressure & 20 bar (6" Hg) vacuum inlet	Minimum speed @ rated pressure	Typical delivery @ rated speed & pressure		Typical input power @ rated speed & pressure	
Model series	Pump size	cc	in <sup>3</sup>	bar	psi	rpm	rpm*	l/min	gpm	kW	hp
G25	7	23	1.41	210	3045	3600	1000	79.0	20.8	32.1	42.9
	9	29	1.79	210	3045	3400	800	94.7	25.0	38.5	51.6
	11	36	2.18	210	3045	3200	600	108.6	28.7	44.2	59.3
	13	43	2.60	210	3045	3000	600	121.4	32.1	49.5	66.3
	15	48	2.94	210	3045	2800	600	128.1	33.9	52.2	70.0
	17	55	3.33	210	3045	2500	600	129.6	34.2	52.7	70.6
	19	62	3.77	210	3045	2500	600	145.2	38.3	59.0	79.1
	21	68	4.13	210	3045	2500	600	157.4	41.6	64.1	85.9
	24	77	4.71	190	2755	2500	600	179.5	47.4	66.1	88.6
	27	87	5.30	175	2540	2300	600	183.8	48.5	62.3	83.6

\*Lower speeds are permissible when operating below rated pressure.

## Efficiency

Depending on displacement, speed and pressure, volumetric efficiency is 81-98% and overall efficiency is 68-86% with fluid at 30 cSt (141 SUS).

## Inlet Conditions

Pressure on the inlet should not exceed .35 bar (5 psi). Under continuous operation, inlet vacuum should not exceed 0.20 bar (6" Hg).

## Operating Temperature

Under continuous operation, a maximum of 95°C (201°F) is recommended. The maximum temperature for cyclic or intermittent operation is 110°C (230°F).

## Fluids and Filtration

For applications requiring fire resistant fluids, water glycols, water in-oil emulsions and synthetics may be used at slightly reduced ratings. We recommend antiwear HL- and HLP-hydraulic fluids according to DIN 51524. Recommended viscosities should be 7 cSt (49.2 SSU) minimum, and 750 cSt (3465 SSU) maximum. For application assistance, consult your Haldex Barnes representative.

The system should be filtered to provide an ISO code (4406) cleanliness level of 19/16. A 25 cm absolute or finer filter sized to accommo-

date full system return line flow, is recommended for most operating environments. Severe conditions may require greater efficiency from the filter.

## Noise Levels

Typical values measured at 210 Bar (3000 PSI) and 2300 RPM with oil at 32 cSt (150 SUS) and 42°C (108°F).

G25-7                      67dB(A)  
G25-13                    72 dB(A)

# Mounting Flanges

## Option 1 2-Bolt SAE

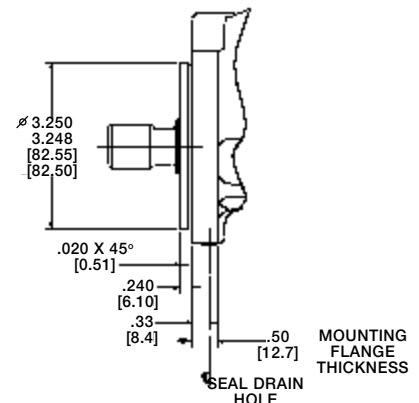
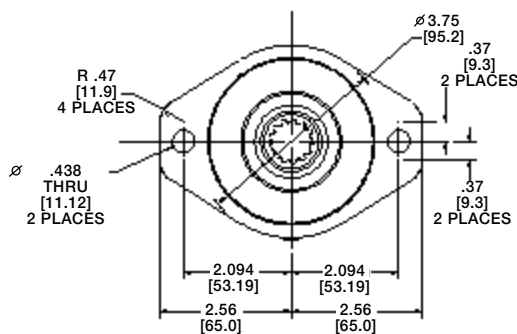

# Mounting Flanges

**Option 2  
2-Bolt SAE "B"**

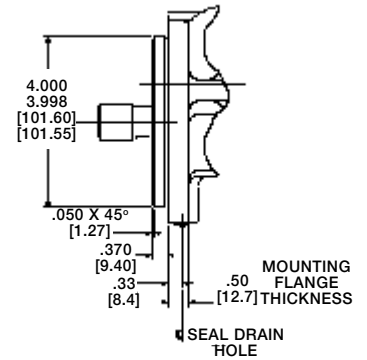
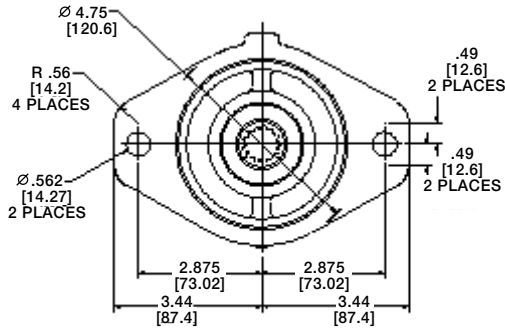

**Option 6  
2/4-Bolt  
Combination  
SAE "B"**

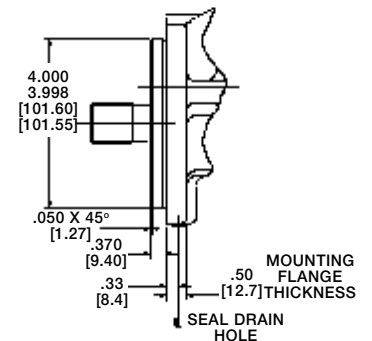
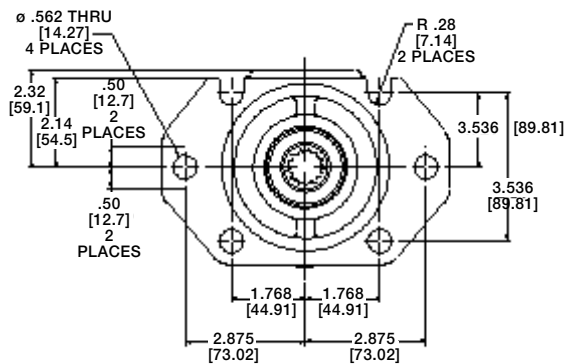

# Drive Shafts

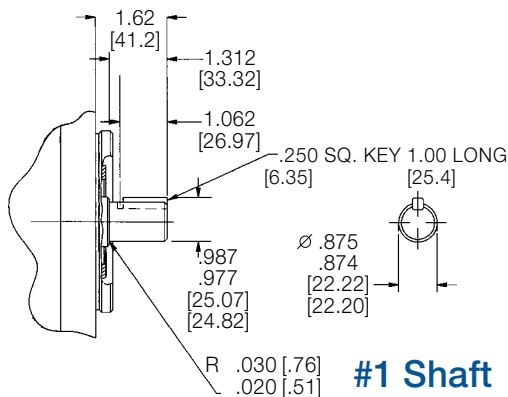

**#1 Shaft**

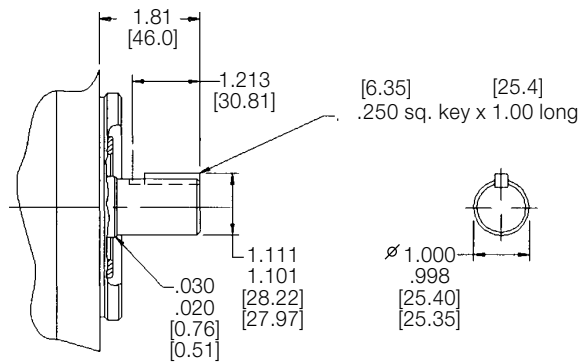

**#21 Shaft**

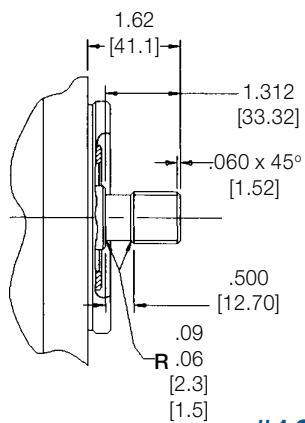

**#12 Shaft**

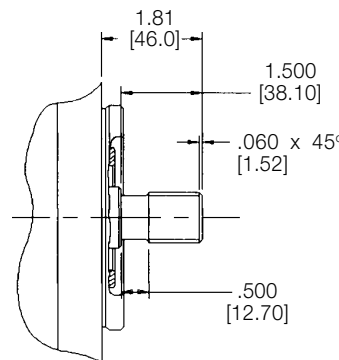

**#99 Shaft**

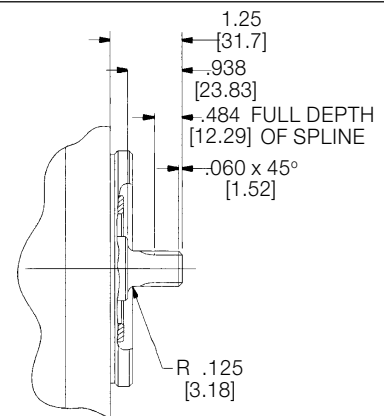

**#17 Shaft**

# Performance Data

G25 TYPICAL MECHANICAL EFFICIENCY

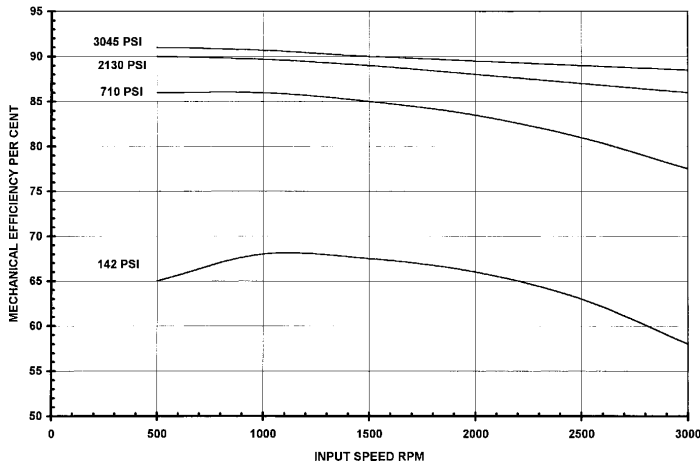

G25 TYPICAL OVERALL EFFICIENCY

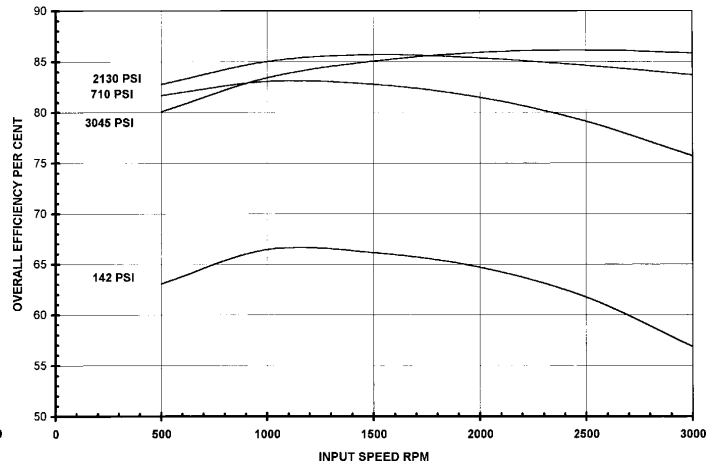

G25 TYPICAL VOLUMETRIC EFFICIENCY

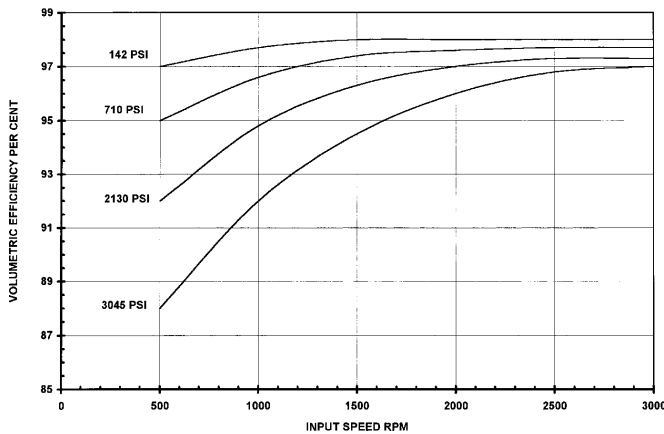

G25-15-20 NOISE CHARACTERISTICS

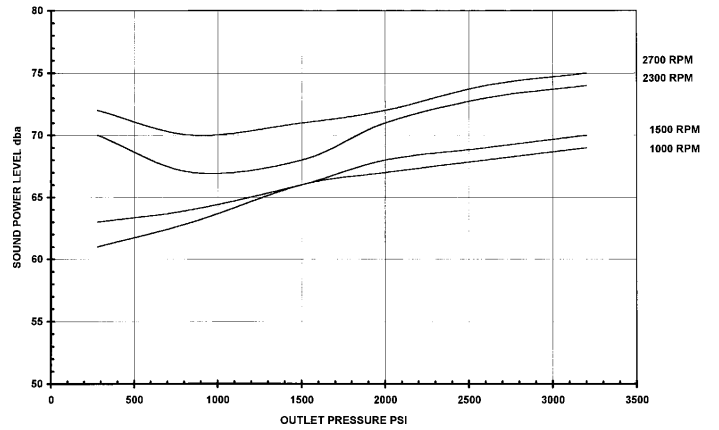

## Port Size & Location Selection Guide

The chart below indicates the port styles and sizes available for a given displacement and port location.

Displacement	Side & Rear Inlet	Side Inlet / Side Outlet	Rear Inlet / Rear Outlet	Port Description Key
23	Q	Q	A, AM, B, BM, C, CM, L, M, Q, S, T, U, V, W	A = 4-Bolt, .75" B = 4-Bolt, 1" C = 4-Bolt, 1.25" D = 4-Bolt, 1.5" L = 1" NPTF M = 1.25" NPTF Q = .75" - 12 S = .875" - 12 T = 1.0625" - 12 U = 1.1875" - 12 V = 1.3125" - 12 W = 1.625" - 12 X = 1.875" - 12
29	L, Q, S	L, Q, S	A, AM, B, BM, C, CM, L, M, Q, S, T, U, V, W	
36	L, S	L, S	A, AM, B, BM, C, CM, L, M, S, T, U, V, W	
43	L, M, S, T	L, M, S, T	A, AM, B, BM, C, CM, L, M, S, T, U, V, W	
48	L, M, S, T, U, V	A, AM, L, M, S, T, U	A, AM, B, BM, C, CM, L, M, S, T, U, V, W	
55	L, M, T, U, V	A, AM, B, BM, L, M, T, U, V	A, AM, B, BM, C, CM, L, M, T, U, V, W	
62	L, M, T, U, V	A, AM, B, BM, C, CM, L, M, T, U, V	A, AM, B, BM, C, CM, L, M, T, U, V, W	
68	L, M, T, U, V, W	A, AM, B, BM, C, CM, L, M, T, U, V, W	A, AM, B, BM, C, CM, L, M, T, U, V, W	
77	L, M, T, U, V, W	C, CM, D, DM, L, M, T, U, V, W, X	B, BM, C, CM, L, M, T, U, V, W	
87	L, M, U, V, W	C, CM, D, DM, L, M, U, V, W, X	B, BM, C, CM, L, M, U, V, W	

# How To Order G25 Series Pumps

## ORDERING INFORMATION

Each option has been assigned an order code -- listed in the tables below -- for placement in the sequence shown at right.

### 1 (Pump Type)

Order Code	Description
G	Gear Pump

### 2 (Pump Series)

Order Code	Description
25	G25 Series

### 3 (Shaft Seal Material)

Order Code	Description
B	Buna N
V	Viton

### 4 (Mounting Flange)

Order Code	Description
1	2-Bolt SAE "A"
2	2-Bolt SAE "B"
6	2/4-Bolt Combination SAE "B"

### 5 (Port Style & Size)

Order Code	Description
A	4-Bolt Flange, 0.75" Dia.
B	4-Bolt Flange, 1.00" Dia.
C	4-Bolt Flange, 1.25" Dia.
D	4-Bolt Flange, 1.50" Dia.
L	1.00" NPTF
M	1.25" NPTF
Q	.750" - 16 Straight Thread
S	.875" - 14 Straight Thread
T	1.0625" - 12 Straight Thread
U	1.1875" - 12 Straight Thread
V	1.3125" - 12 Straight Thread
W	1.6250" - 12 Straight Thread
X	1.8750" - 12 Straight Thread

### 6 (Displacement)

Order Code	Description
23	23 cc / 1.4 in. <sup>3</sup>
29	29 cc / 1.76 in. <sup>3</sup>
36	36cc / 2.19 in. <sup>3</sup>
43	43 cc / 2.62 in. <sup>3</sup>
48	48 cc / 2.92 in. <sup>3</sup>
55	55 cc / 3.35 in. <sup>3</sup>
62	62 cc/3.78 in. <sup>3</sup>
68	68 cc/4.14 in. <sup>3</sup>
77	77 cc/4.69 in. <sup>3</sup>
87	87 cc/5.3 in. <sup>3</sup>

**EXAMPLE:**

**G-25-B-2- T- 55-B-12-A-20-B-XXX**

1	2	3	4	5	6	7	8	9	10	11	12
Pump Type	Pump Series	Shaft Seal Material	Mounting Flange	Port Size	Pump Displacement	Shaft Seal	Shaft Type	Port Locations	Design Series	Rotation	Special Design

### 7 (Shaft Seal)

Order Code	Description
A	Single Seal
B	Double Seal
C	Single Seal with Outboard Bearing

### 8 (Shaft Type)

Order Code	Description
1	SAE "B" Straight Keyed, .875" dia., 1.312" ext.
12	SAE "B" 13 Tooth Spline (Flat Root-Side Fit)
17	SAE "A" 9-Tooth Spline (Flat Root-Side Fit)
21	SAE "BB" Straight Keyed 1" dia., 1.50" ext.
99	SAE "BB" 15 Tooth Spline (Flat Root-Side Fit)

Contact factory for other options.

### 9 (Port Locations)

Order Code	Description
A	Side & Rear Inlet / Side & Rear Outlet *
B	Side Inlet / Side Outlet **
C	Rear Inlet / Rear Outlet **
D	Same as Option A, except with Case Drain
E	Same as Option B, except with Case Drain **
F	Same as Option C, except with Case Drain **

\* NOTE: Port Location "A" not available with port size "X" on displacements "77" or "87" cc.

\*\* Split flange option available on rear only or side only.

### 10 (Design Series)

Order Code	Description
20	Design Series

### 11 (Rotation)

Order Code	Description
B	Birotational

### 12 (Special)

Order Code	Description
xxx	Special Design Designation



Haldex Barnes Corporation  
 Statesville Division  
 214 James Farm Road  
 Statesville, NC 28677 • USA  
 Phone 704/873-2587  
 Fax 704/878-0530

Haldex Barnes Corporation  
 2222 15th St.  
 Rockford, IL 61104 • USA  
 Phone 815/398-4400  
 Fax 815/398-5977

DISTRIBUTED BY: