

ISO 9001:2008 by L.R.  
PED DIR. 97/23/EC by L.R.  
ATEX DIR. 94/9/EC by B.V.  
FIRE SAFE EXECUTION by L.R.  
ISO 15848 by TÜV  
ANTISTATIC DEVICE by L.R.  
FIRE SAFE TESTED ISO 10497 by L.R.

TYPE  
**VE2**  
ANSI 150

NORME E DIRETTIVE APPLICATE DISPONIBILI AL SEGUENTE LINK:  
STANDARD AND DIRECTIVE APPLIED AVAILABLE AT FOLLOWING LINK:  
[http://www.adlerspa.com/pdf/NORME\\_ADLER.pdf](http://www.adlerspa.com/pdf/NORME_ADLER.pdf)

## VALVOLE A SFERA "ANSI B16.10" PASSAGGIO VENTURI

ISO nbr° LRC 0160281 QMS issued by L.R.Q.A. PED nbr° COV 0212112/01 issued by L.R.V.  
ATEX nbr° 40.2003.4392 issued by B.V. ISO 15848 nbr° I-148466/1-/2 issued by TÜV

FULL BORE ACCORDING  
TO ISO 14313

On request  
FIRE SAFE  
According to ISO 10497  
"ISO-FT"

On request  
S.I.L. 3  
According to IEC 61508

CONSTRUCTION ACCORDING TO:  
BS EN 12516-2 - ANSI B16.34  
ISO 14313 - ANSI B16.5  
ANSI B16.10/UNI EN 558-2

**BALL VALVES**  
**"ANSI B16.10" VENTURI PORT**  
**ROBINETS A BOISSEAU SPHERIQUE**  
**"ANSI B16.10" PASSAGE VENTURI**  
**FLANSCHKUGELHÄHNE IN "ANSI B16.10"**  
**REDUZIERTER DURCHGANG**

WEB SITE: [WWW.ADLERSPA.COM](http://WWW.ADLERSPA.COM)

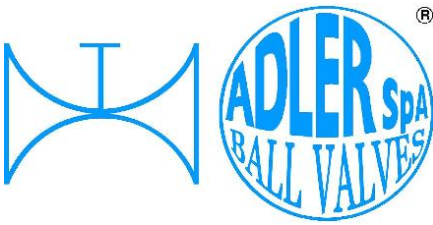

ISO 9001:2008 by L.R.  
 PED DIR. 97/23/EC by L.R.  
 ATEX DIR. 94/9/EC by B.V.  
 FIRE SAFE EXECUTION by L.R.  
 ISO 15848 by TÜV  
 ANTISTATIC DEVICE by L.R.  
 FIRE SAFE TESTED ISO 10497 by L.R.

TYPE  
**VE2**  
 ANSI 150

VALVOLA A SFERA "ANSI B 16.10" PASSAGGIO VENTURI  
 BALL VALVES "ANSI B 16.10" VENTURI PORT  
 ROBINETS A BOISSEAU SPHERIQUE "ANSI B 16.10" PASSAGE VENTURI  
 FLANSCHKUGELHÄHNE IN "ANSI B 16.10" REDUZIERTER DURCHGANG

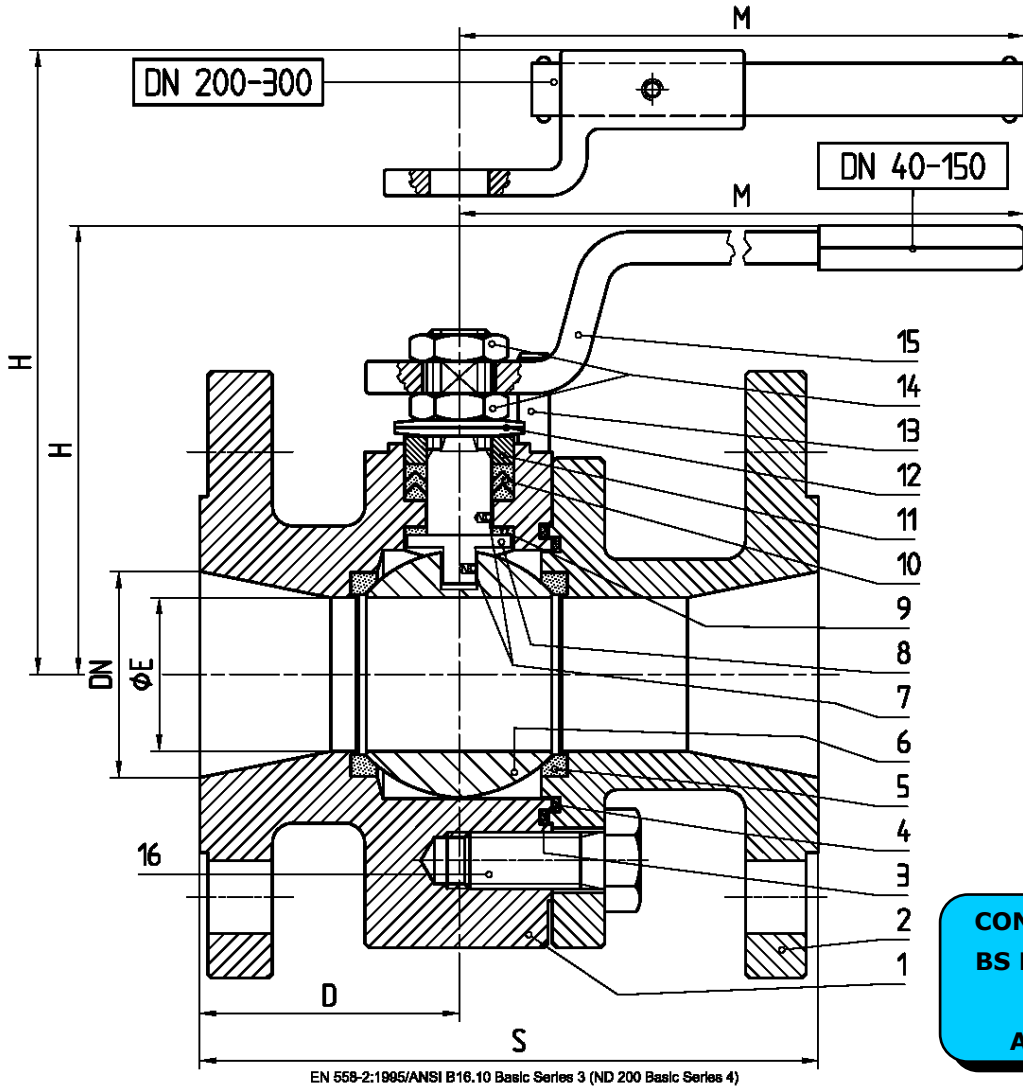

DN 300  
 -CONSIGLIATO  
 RIDUTTORE MANUALE  
 -MANUAL GEAR BOX  
 SUGGESTED  
 -REDUCTEUR MANUEL  
 CONSEILLE  
 -EMPFEHLEN WIR EIN  
 HANDGETRIEBE

CONSTRUCTION ACCORDING TO:  
 BS EN 12516-2 - ANSI B16.34  
 ISO 14313 - ANSI B16.5  
 ANSI B16.10/UNI EN 558-2

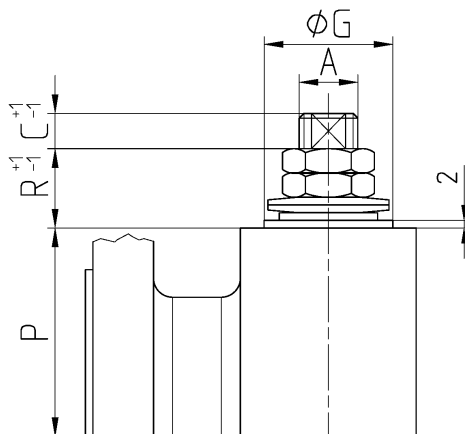

• ACCOPPIAMENTO VALVOLA  
 ATTUATORE  
 • CONNECTION VALVE  
 ACTUATOR  
 • ACCOUPLEMENT ROBINET-  
 ACTIONNEUR  
 • ZUSAMMENBAU KUGELHAHN  
 • ANTRIEB  
**ISO-5211**

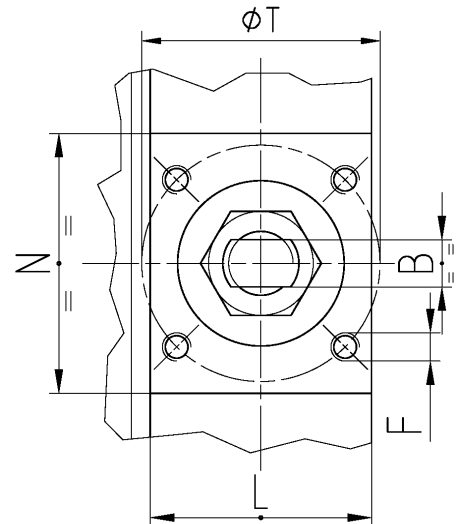

N.	DESCRIZIONE DESCRIPTION BESCHREIBUNG	MATERIALI MATERIALS MATERIAUX WERKSTOFFE
1	CORPO BODY CORPS KÖRPER	ASTM A105 ASTM A479 316/316L ASTM A 351 CF8M
2	LATERALE END LATERAL GEGENGEHÄUSE	ASTM A105 ASTM A479 316/316L ASTM A 351 CF8M
3*	O-RING	FKM - (VITON)
4*	ANELLO SEAL ANNEAU DICHTUNGSRING	P.T.F.E.
5*	SEDE SEAT SIEGE SITZRING	P.T.F.E. (BAM CERTIFIED) R.P.T.F.E. (OPTIONAL)
6	SFERA BALL BOULE KUGEL	ASTM A479 304/304L ASTM A351 CF8  ASTM A479 316/316L ASTM A351 CF8M
7	DISPOSITIVO ANTISTATICO ANTISTATIC DEVICE CONTACT ANTISTATIQUE ANTISTATIK VORRICHTUNG	ASTM A479 316/316L
8	STELO STEM TIGE SPINDEL	ASTM A479 304/304L  ASTM A479 316/316L

N.	DESCRIZIONE DESCRIPTION BESCHREIBUNG	MATERIALI MATERIALS MATERIAUX WERKSTOFFE
9*	BUSSOLA STEM SEAL JOINT TIGE UNTERE SPINDELABDICHTUNG	P.T.F.E.
10*	PACCO A "V" CHEVRON RINGS JOINT A "V" 3 FACHE DACHMANSCHETTE	P.T.F.E. / GRAFITE P.T.F.E. / GRAPHITE P.T.F.E. / GRAPHITE P.T.F.E. / GRAPHIT
11	PREMIBUSSOLA PRESSING BUSH PRESSE RONDELLE STOPFBUCHSDRUCKRING	ASTM A479 304
12	MOLLE A TAZZA SPRING WASHERS RONDELLES BELLEVILLE TELLERFEDERN	C72/50Cr V4  X5CrNi17.7 or X12CrNi17.7  ZINCATO - GALVANIZED - ZINGUE - VERZINKT  ON REQUEST
13	VITE DI FERMO E FERMO PIN AND STOP PIN PLOT ET PLOT D'ARRET ANSCHLAGBOLZEN	UNI 3740 8.8  UNI 3951 A2-70  ZINCATO - GALVANIZED - ZINGUE - VERZINKT  ON REQUEST
14	DADO - CONTRODADO NUT - LOCK NUT ECROU - CONTRE-ECROU MUTTER - KONTERMUTTER	UNI 3740 - 6S  ASTM A479 304  ZINCATO - GALVANIZED ZINGUE - VERZINKT  ON REQUEST
15	LEVA WRENCH LEVIER HANDHEBEL	AISI 1010  ASTM A479 304  ZINCATO - GALVANIZED ZINGUE - VERZINKT  ON REQUEST
16	VITE SCREW VIS SCHRAUBE	UNI 3740 8.8  UNI 3951 A2-70  ZINCATO - GALVANIZED - ZINGUE - VERZINKT  ON REQUEST

\* RICAMBI CONSIGLIATI - RECOMMENDED SPARE PARTS - PIECES DE RECHANGE CONSEILLEES - ERSATZTEIL EMPFEHLUNG

## DIMENSIONI - DIMENSION - DIMENSIONS - ABMESSUNGEN

DN	15	20	25	32	40	50	65	80	80	100	125	150	150	200	250	300
A					12	16	16	16	22	22	30	30	30	42	48	48
B					8	10	10	10	14	14	18	18	18	28	32	32
C					7	9	9	9	12	12	17	17	17	19	19	20
D					61	61	65	81	76	77,5	89	119	109	122	144	158
E					30	38	51	51	64	76	101	101	118	152	187	203
F					M5	M6	M6	M6	M8	M8	M8	M8	M10	M12	M16	M16
ISO					F03	F05	F05	F05	F07	F07	F07	F07	F10	F12	F14	F14
G	VEDERE TYPE SEE VOIR SIEHE				25	35	35	35	55	55	55	55	70	85	100	100
H	FE2				119	110	120	120	144	152	174	174	188	256	284	295
L	ANSI 150				34	45	45	46	62	62	64	80	104,5	128	146	170
M					185	280	280	280	370	370	470	470	650	750	750	900
N					40	60	62	64	84	73	81	115	107	139	147	141
P					46,5	55	65	65	82	90,5	99,5	99,5	113	144	172,5	193
R					17	20	20	20	23	23	26	26	26	34	37	27
S					165	178	190	203	203	229	254	267	267	292	330	356
T					36	50	50	50	70	70	70	70	102	125	140	140
~Kg					7,7	12	65	21	20	32,8	49	55,7	52,6	85	145	210

- DATI E CARATTERISTICHE SOGGETTI A VARIAZIONI SENZA PREAVVISO
- SPECIFICATIONS SUBJECT TO MODIFICATION WITHOUT PRIOR NOTICE
- TOUS DROITS DE MODIFICATION RESERVES
- KONSTRUKTIONSÄNDERUNGEN VORBEHALTEN



ADLER SpA - BALL VALVES  
20010 S. STEFANO TICINO (MI) ITALY V.le BORLETTI, 14 Tel. +39/02974842.11 FAX +39/0297271698  
E-mail: [adler@adlerspa.com](mailto:adler@adlerspa.com) <http://www.adlerspa.com>

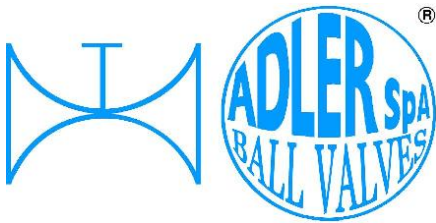

ISO 9001:2008 by L.R.  
 PED DIR. 97/23/EC by L.R.  
 ATEX DIR. 94/9/EC by B.V.  
 FIRE SAFE EXECUTION by L.R.  
 ISO 15848 by TÜV  
 ANTISTATIC DEVICE by L.R.  
 FIRE SAFE TESTED ISO 10497 by L.R.

TYPE  
**VE2**  
 ANSI 150

VALVOLA A SFERA "ANSI B16.10" PASSAGGIO VENTURI  
 BALL VALVES "ANSI B16.10" VENTURI PORT

ROBINETS A BOISSEAU SPHERIQUE "ANSI B16.10" PASSAGE VENTURI  
 FLANSCHKUGELHÄHNE IN "ANSI B16.10" REDUZIERTER DURCHGANG

• ESECUZIONI • EXECUTIONS • EXECUTIONS • AUSFÜHRUNGEN

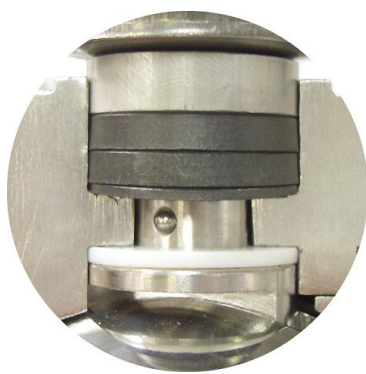

EXECUTION 4 - 12

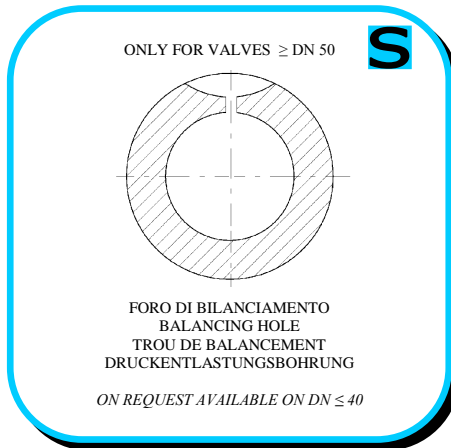

EXECUTION 6 - 16

**S** STANDARD

**O** OPTIONAL

**1** **S**  
**CARBON STEEL**  
 ASTM A105  
 DN 15 ÷ 300  
 or  
 ASTM A 216 WCB  
 DN 125 ÷ 300

**2** **S**  
**STAINLESS STEEL**  
 ASTM A479 S31600  
 DN 15 ÷ 100  
 ASTM A351 CF8M  
 DN 125 ÷ 300

**3** **O**  
**PN**  
**10 ÷ 40**

**4** **S**  
 -STELO ANTI ESPULSIONE -ANTI BLOW OUT STEM  
 -TIGE ANTIEXPULSION -AUSBLASGESICHERTE WELLE

-PACCO A "V" -CHEVRON RINGS  
 -JOINT A "V" -3 FACHE DACHMANSCHETE  
 ANTISTATIC DEVICE ANTISTATIK VORRICHTUNG  
 BS 5146

**AQUILA - EAGLE - AIGLE**  
**ADLER**

**6** **O**  
**BREVETTO - PATENTED**  
**00219688**

FKM (VITON)  
 -"O" RING STELO "O" RING ON STEM  
 -TIGE AVEC "O" RING  
 -"O" RING IM SPINDELBEREICH

VE2/15 RIPRODUZIONE VIETATA - COPYRIGHT



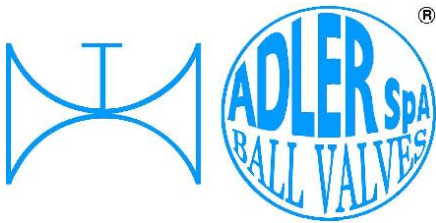

ISO 9001:2008 by L.R.  
 PED DIR. 97/23/EC by L.R.  
 ATEX DIR. 94/9/EC by B.V.  
 FIRE SAFE EXECUTION by L.R.  
 ISO 15848 by TÜV  
 ANTISTATIC DEVICE by L.R.  
 FIRE SAFE TESTED ISO 10497 by L.R.

TYPE  
**VE2**  
 ANSI 150

VALVOLA A SFERA "ANSI B16.10" PASSAGGIO VENTURI  
 BALL VALVES "ANSI B16.10" VENTURI PORT

ROBINETS A BOISSEAU SPHERIQUE "ANSI B16.10" PASSAGE VENTURI  
 FLANSCHKUGELHÄHNE IN "ANSI B16.10" REDUZIERTER DURCHGANG

• ESECUZIONI • EXECUTIONS • EXECUTIONS • AUSFÜHRUNGEN

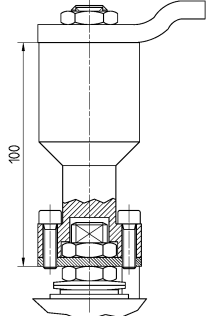
**7**  **O**

-PROLUNGA STELO -STEM EXTENSION  
 -TIGE PROLONGEE -SPINDELVERLÄNGERUNG

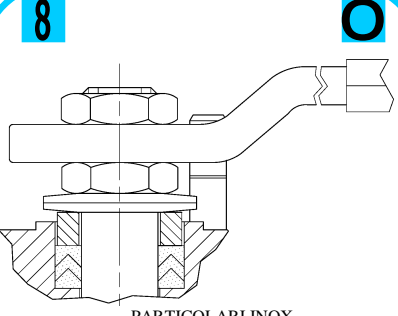
**8**  **O**

-PARTICOLARI INOX -STAINLESS STEEL DETAILS  
 -ACCESSOIRES EN INOX -EDELSTAHLTEILE

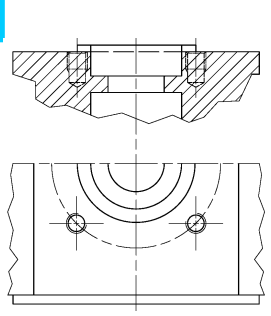
**9**  **S**

-ATTACCO "ISO" -"ISO" CONNECTIONS  
 -SYSTEM "ISO" -ANSCHLUSS "ISO"

**TESTING**

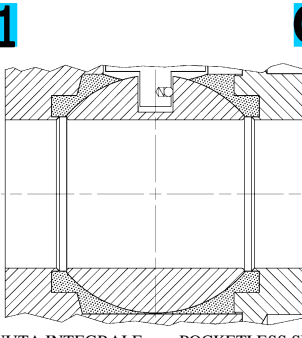

**11**  **O**

-TENUTA INTEGRALE -POCKETLESS SEATS  
 -TENUCE INTEGRALE -TOTRAUMARM  
 -P.T.F.E. / R.T.F.E.

**12** **FIRE SAFE**  
 ISO 10497 "ISO-FT"  
 (BS 6755 / API 607)

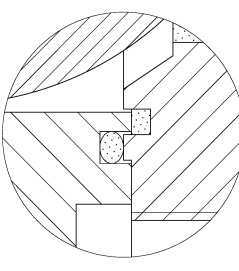

**13**  **S**

**BREVETTO - PATENTED**  
 00219619

-DOPPIA TENUTA -DOUBLE SEALS  
 -DOUBLE ETANCHEITE -DOPPELTE ABDICHTUNG  
 -LATERALE A BATTUTA -METAL BEATING END  
 -LATERAL AVEC BATTUE MECANIQUE  
 -METALLISCHER ANSCHLAG DES GEGENGEHÄUSES

**14** **VEDERE / SEE ANSI B16.34** **O**



FLUSSO  
 FLOW

-TROU DE COMPRESSION DANS LA BOULE  
 -ENTLASTUNGSBOHRUNG IN DER KUGEL  
**VALVOLA MONO DIREZIONALE**  
 MONO-DIRECTIONAL VALVE

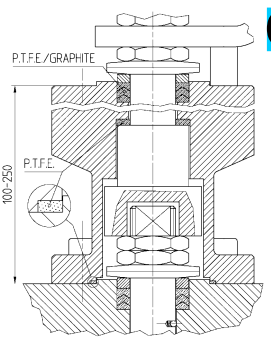
**15**  **O**

P.T.F.E./GRAPHITE  
 P.T.F.E.  
 100-250

-SERVIZIO CRIOGENICO - CRYOGENIC SERVICE  
 -SERVICE CRYOGÉNIQUE  
 -TIEFTEMPERATUR SERVICE

**16**  **O**

-FIRE SAFE ISO FT + "O" RING STELO  
 -FIRE SAFE ISO FT + "O" RING ON STEM  
 -SECURITE FEU ISO FT + TIGE AVEC "O" RING  
 -FEUERSICHERE AUSFÜHRUNG ISO FT +  
 "O" RING IM SPINDELBEREICH

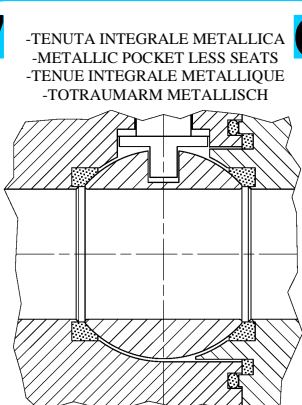
**17**  **O**

-TENUTA INTEGRALE METALLICA  
 -METALLIC POCKET LESS SEATS  
 -TENUCE INTEGRALE METALLIQUE  
 -TOTRAUMARM METALLISCH

**ADLER**

UNA GAMMA COMPLETA  
 PRIVILEGIANDO LA QUALITA'

A COMPLETE RANGE PRIVILEGING  
 THE QUALITY

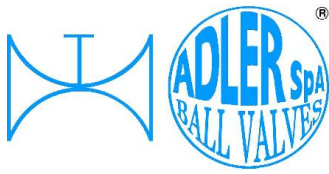

**DIMENSIONI FLANGE VE2  
FLANGE DIMENSION VE2  
DIMENSIONS BRIDES VE2  
FLANSCHANSCHLUSSMASSE VE2**

**TABLE  
04**

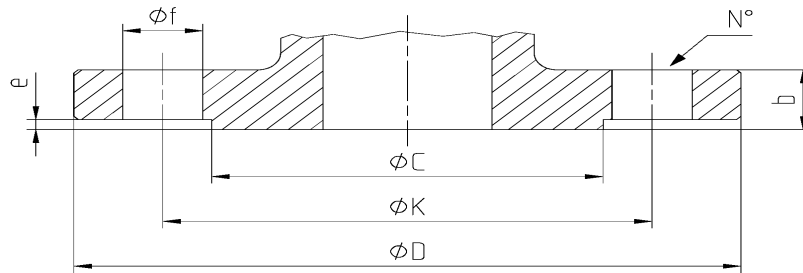

**ANSI B16.5**

DN	Ref.	½"	¾"	1"	1 ¼"	1 ½"	2"	2 ½"	3"	4 "	5"	6"	8"	10"	12"	
ANSI 150 RF	D					127	152.4	177.8	190.5	228.6	254	279.4	342.9	406.4	482.6	
	C					92	104.7	127	157.3	185.7	215.9	269.8	269.8	323.9	381	
	K					98.6	120.7	139.7	152.4	190.5	215.9	241.3	298.5	362	431.8	
	N°					4	4	4	4	8	8	8	8	12	12	
	f					19.1	19.1	19.1	19.1	19.1	22.4	22.4	22.4	25.4	25.4	
	b					17.6	19.1	22.4	23.9	23.9	23.9	23.9	25.4	28.5	30.3	31.8
	e					1.6	1.6	1.6	1.6	1.6	1.6	1.6	1.6	1.6	1.6	1.6

**EN 1092-1 (OPTIONAL)**

DN	Ref.	10	15	20	25	32	40	50	65	80	100	125	150	200	250	300	
PN 10	D						150	165	185	200	220	250	285	340	395	445	
	C						88	102	122	138	158	188	212	268	320	370	
	K						110	125	145	160	180	210	240	295	350	400	
	N°						4	4	4*	8	8	8	8	8	12	12	
	f						18	18	18	18	18	18	22	22	22	22	
	b						18	18	18	20	20	20	22	22	24	26	26
	e						3	3	3	3	3	3	3	3	3	3	4
PN 16	D						150	165	185	200	220	250	285	340	405	460	
	C						88	102	122	138	158	188	212	268	320	378	
	K						110	125	145	160	180	210	240	295	355	410	
	N°						4	4	4*	8	8	8	8	12	12	12	
	F						18	18	18	18	18	18	22	22	26	26	
	b						18	18	18	20	20	20	22	22	24	26	28
	e						3	3	3	3	3	3	3	3	3	3	4
PN 25	D						150	165	185	200	235	270	300	360	425	485	
	C						88	102	122	138	162	188	218	278	335	395	
	K						110	125	145	160	190	220	250	310	370	430	
	N°						4	4	8	8	8	8	8	12	12	16	
	f						18	18	18	18	22	26	26	26	30	30	
	b						18	20	22	24	24	24	26	28	30	32	34
	e						3	3	3	3	3	3	3	3	3	3	4
PN 40	D						150	165	185	200	235	270	300	375	450	515	
	C						88	102	122	138	162	188	218	285	345	410	
	K						110	125	145	160	190	220	250	320	385	450	
	N°						4	4	8	8	8	8	8	12	12	16	
	f						18	18	18	18	22	26	26	30	33	33	
	b						18	20	22	24	24	24	26	28	34	38	42
	e						3	3	3	3	3	3	3	3	3	3	4

\* n° 8 fori su richiesta

