

# KEYSTONE

- 60W – Wafer style resilient seated butterfly valve
- 60L – Lug style resilient seated butterfly valve
- Cartridge Seat Design

## Features and Benefits

- Suitable for high pressure and full vacuum service due to the use of a cartridge seat design.
- Triple function cartridge seat isolates the body and stem from the media, provides positive drop-tight shut-off of line media at full rated pressure and provides a flange seal, eliminating the need for flange gaskets.
- Full rated unidirectional dead-end service is achieved by utilizing a unique patented lip in the lug body.
- Strong disc-to-stem connection and elimination of exposed pins or bolts is achieved through a rectangular drive.
- Ability to install the valve with the disc in the closed position eliminates the risk of damage to the valve during installation.
- Maximum flow and rangeability is achieved with the use of a streamlined disc.
- Stems are blowout-proof stems as a standard.
- Longer seat life with low operating torques is ensured by utilizing upper and lower stem bearings.
- Need for costly brackets is eliminated due to the ability to direct mount actuation onto the valve top-plate.



## General Application

Ideally suited for many industrial applications such as food and beverage, pulp and paper, chemical, mining, water treatment, power, and automotive where a heavy-duty resilient seated butterfly valve is required. Available in a wide variety of body, disc and seat materials to fit a wide variety of media applications.

## Technical Data

|                  |   |
|------------------|---|
| Size Range:      | 2" to 24" wafer and lug styles                                |
| Pressure Rating: | 2" to 12" – 250 psi<br>14" to 24" – 200 psi                   |
|                  | Teflon® seat or elastomer covered disc<br>2" to 12" – 150 psi |
| Dead End Rating: | Full rated in preferred direction of flow                     |
| Flange Standard: | ASME Class 125/150  |

Designed to comply with MSS-SP-67 and API 609 (may be shell tested to spec on request).

# Keystone Butterfly Valves – Series 60

2" to 24"

## Specifications

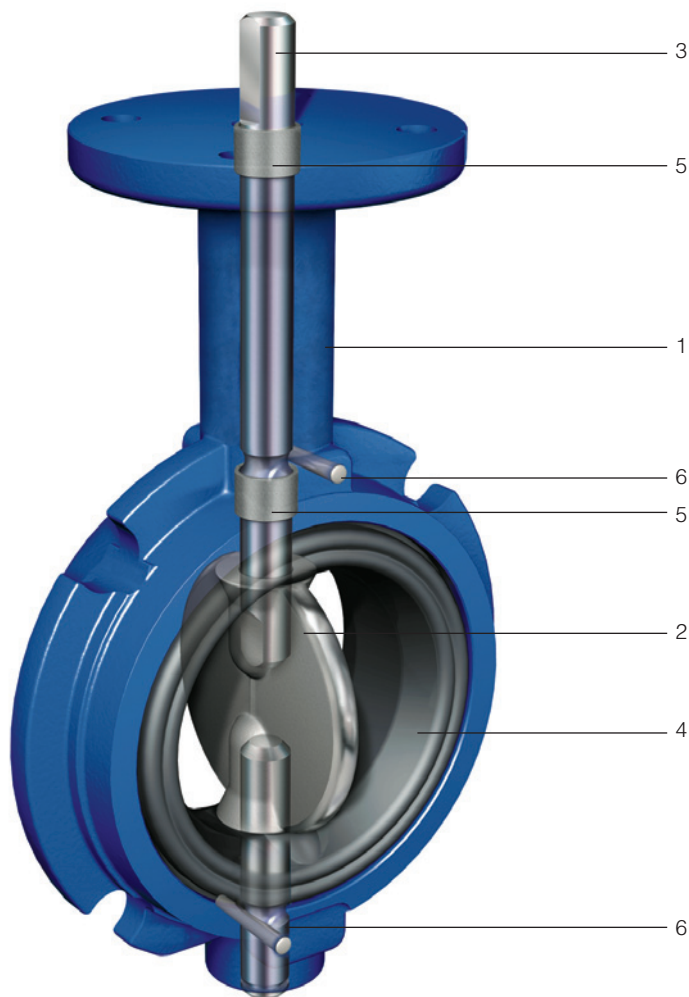

### Materials

| Part                   | Standard Material  | Material Specifications   |
|------------------------|--|---|
| 1 Body                 | Cast Iron <sup>1</sup><br>Ductile Iron (2" to 12")<br>Ductile Iron <sup>2</sup> (14" to 24" Lug style)<br>316 Stainless Steel <sup>3</sup> | ASTM A126 Class B<br>ASTM A395 Grade 60/40/18<br>ASTM A536 Grade 65/45/12<br>ASTM A351 CF8M |
| 2 Disc                 | Ductile Iron/Nickel Plated<br>Aluminum Bronze<br>316 Stainless Steel<br>EPDM Coated (2" to 12")<br>NBR Coated (2" to 12")                  | ASTM A536 Grade 65/45/12<br>ASTM B148 C95400<br>ASTM A351 CF8M                              |
| 3 Stem                 | 416 Stainless Steel (standard)<br>316 Stainless Steel (optional) <sup>4</sup>  | ASTM A582 UNS S41600 Cond. A<br>ASTM A276 UNS S31600 Cond. A                                |
| 4 Seat                 | EPDM Food Grade (-20°F – 250°F)<br>NBR (0°F – 180°F)<br>Fluoroelastomer (0°F – 300°F)<br>Teflon® (-20°F – 250°F) (2" to 12")               |   |
| 5 Bearing <sup>5</sup> | Teflon® Gar-Fil® (2" to 24")   |   |
| 6 Pin                  | Carbon Steel   |   |

#### Notes:

1. 14" and larger Wafer style available in Cast Iron Body only.
2. 14" and larger Lug style available in Ductile Iron Body only.
3. Offered in 2" to 6" only. These bodies come standard with a vented shaft and food grade seats.
4. 316 Stainless Steel Stem available in 2" to 12" only.
5. Valves with 316 SS bodies are provided with two additional bearings in the lower stem journal.

## Specifications

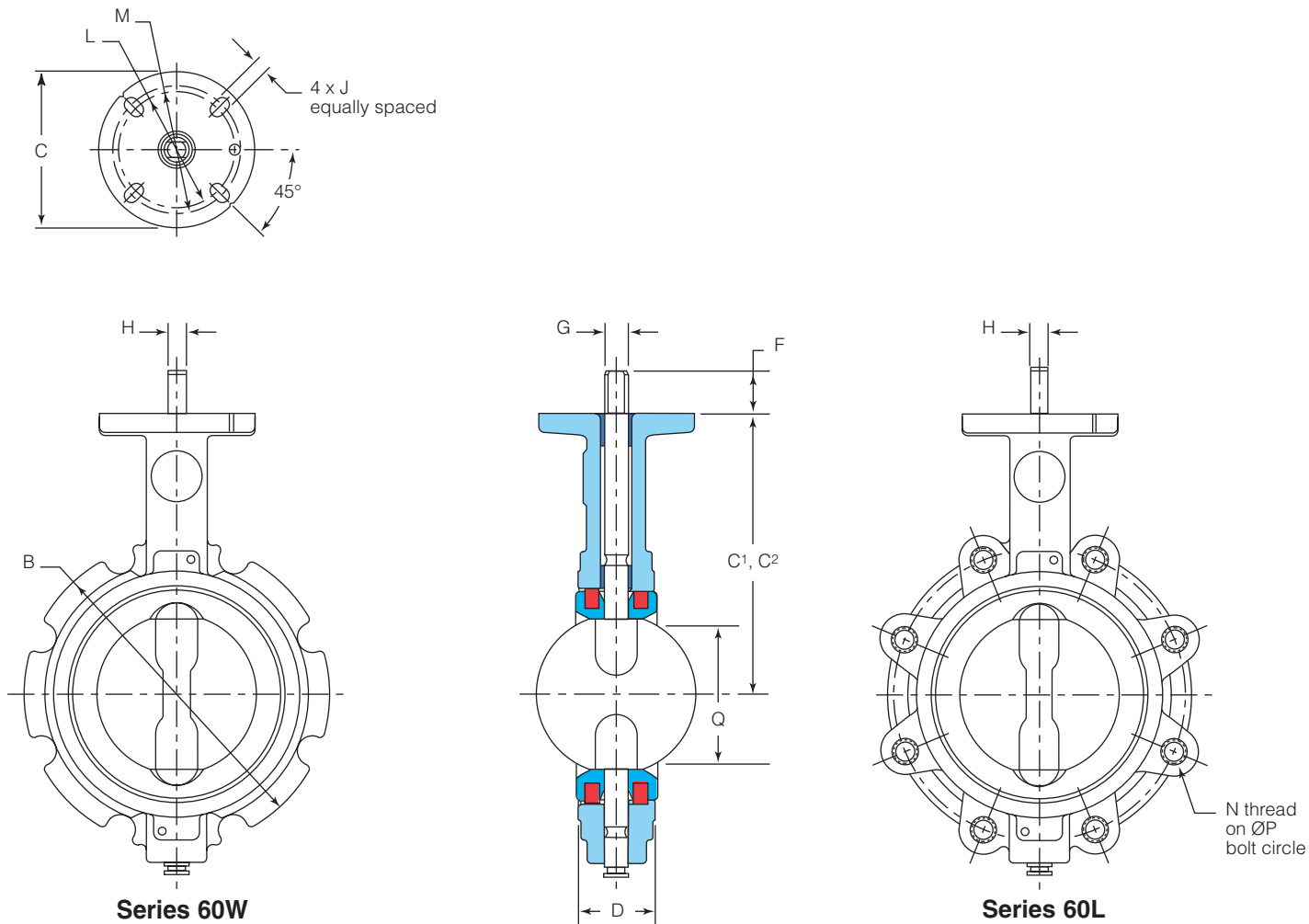

### Dimensions (inches)

| Size   | B     | C <sup>1</sup> | C <sup>2</sup> | D    | E    | F    | G    | H    | J     | L    | M    | N       | P     | Q*    | Key         | Adapt. Code |
|--------|-------|----------------|----------------|------|------|------|------|------|-------|------|------|---------|-------|-------|-------------|-------------|
| 2"     | 5.09  | 5.75           | 4.69           | 1.63 | 4.00 | 1.25 | 0.56 | 0.37 | 0.406 | 3.00 | 3.25 | 5/8-11  | 4.75  | 1.41  | –           | BAB         |
| 2 1/2" | 5.81  | 6.25           | –              | 1.75 | 4.00 | 1.25 | 0.56 | 0.37 | 0.406 | 3.00 | 3.25 | 5/8-11  | 5.50  | 1.82  | –           | BAB         |
| 3"     | 6.25  | 6.50           | 4.87           | 1.75 | 4.00 | 1.25 | 0.56 | 0.37 | 0.406 | 3.00 | 3.25 | 5/8-11  | 6.00  | 2.62  | –           | BAB         |
| 4"     | 7.81  | 7.25           | 6.00           | 2.00 | 4.00 | 1.25 | 0.63 | 0.43 | 0.406 | 3.00 | 3.25 | 5/8-11  | 7.50  | 3.62  | –           | BAC         |
| 5"     | 8.75  | 7.75           | –              | 2.13 | 4.00 | 1.25 | 0.75 | 0.50 | 0.406 | 3.00 | 3.25 | 3/4-10  | 8.50  | 4.67  | –           | BAD         |
| 6"     | 9.75  | 8.38           | 6.50           | 2.14 | 4.00 | 1.25 | 0.75 | 0.50 | 0.406 | 3.00 | 3.25 | 3/4-10  | 9.50  | 5.68  | –           | BAD         |
| 8"     | 12.00 | 9.62           | –              | 2.35 | 6.00 | 1.25 | 0.87 | 0.63 | 0.562 | 5.00 | –    | 3/4-10  | 11.75 | 7.54  | –           | CAE         |
| 10"    | 14.50 | 11.00          | –              | 2.63 | 6.00 | 2.00 | 1.12 | –    | 0.562 | 5.00 | –    | 7/8-9   | 14.25 | 9.65  | 1/4 x 1/4   | CAF         |
| 12"    | 17.50 | 12.50          | –              | 3.00 | 6.00 | 2.00 | 1.37 | –    | 0.562 | 5.00 | –    | 7/8-9   | 17.00 | 11.49 | 5/16 x 5/16 | CAG         |
| 14"    | 19.50 | 13.25          | –              | 3.06 | 6.00 | 3.00 | 1.37 | –    | 0.531 | 5.00 | –    | 1-8     | 18.75 | 12.97 | 5/16 x 5/16 | CAG         |
| 16"    | 22.06 | 14.75          | –              | 4.01 | 6.00 | 3.00 | 1.63 | –    | 0.531 | 5.00 | –    | 1-8     | 21.25 | 14.85 | 3/8 x 3/8   | CAH         |
| 18"    | 23.44 | 15.75          | –              | 4.48 | 6.75 | 3.00 | 1.63 | –    | 0.531 | 5.00 | –    | 1 1/8-7 | 22.75 | 16.76 | 3/8 x 3/8   | CAH         |
| 20"    | 25.68 | 16.25          | –              | 4.99 | 6.75 | 4.25 | 1.88 | –    | 0.812 | 6.50 | –    | 1 1/8-7 | 25.00 | 18.72 | 1/2 x 3/8   | DAJ         |
| 24"    | 30.06 | 19.12          | –              | 6.00 | 8.00 | 4.25 | 1.88 | –    | 0.812 | 6.50 | –    | 1 1/4-7 | 29.50 | 22.59 | 1/2 x 3/8   | DAJ         |

C<sup>1</sup> Dimensions apply to Cast Iron and Ductile Iron bodies ONLY.

C<sup>2</sup> Dimensions apply to Stainless Steel bodies ONLY.

Q\* Dimension is the minimum allowable pipe or flange inside diameter at the centered body face to protect the disc sealing edge against damage when opening the valve.

# Keystone Butterfly Valves – Series 60

2" to 24"

## Valve Sizing

Rate of flow through a valve depends upon the pressure drop. The most common method of presenting this information is by  $C_v$ . The  $C_v$  is the valve coefficient of flow and represents the

flow of water in gallons per minute (GPM) with a 1 psi pressure drop through the valve. The higher the  $C_v$ , the greater the flow and the better the control characteristics. Throttling

characteristics are shown in the same manner with  $C_v$ 's at the various disc openings. Tabulated below are the  $C_v$ 's for the Series 60 Butterfly Valve.

**$C_v$  Chart (Water @ 70°F, Specific Gravity = 1.00)**

| Valve Size | Disc position (Degrees Open) |       |       |       |        |        |        |        |
|------------|------------------------------|-------|-------|-------|--------|--------|--------|--------|
|            | 25°                          | 30°   | 40°   | 50°   | 60°    | 70°    | 80°    | 90°    |
| 2"         | 3                            | 7     | 19    | 36    | 63     | 84     | 115    | 120    |
| 2 1/2"     | 4                            | 10    | 24    | 47    | 78     | 113    | 182    | 194    |
| 3"         | 14                           | 21    | 45    | 84    | 133    | 203    | 382    | 430    |
| 4"         | 30                           | 52    | 100   | 165   | 270    | 420    | 703    | 830    |
| 5"         | 85                           | 130   | 210   | 345   | 525    | 825    | 1,350  | 1,500  |
| 6"         | 165                          | 225   | 360   | 570   | 820    | 1,260  | 1,875  | 1,980  |
| 8"         | 210                          | 300   | 480   | 780   | 1,320  | 2,280  | 3,780  | 3,870  |
| 10"        | 405                          | 575   | 850   | 1,200 | 1,900  | 3,300  | 6,100  | 6,450  |
| 12"        | 550                          | 750   | 1,200 | 1,875 | 2,850  | 5,025  | 9,300  | 9,800  |
| 14"        | 650                          | 825   | 1,500 | 2,300 | 3,500  | 6,200  | 9,700  | 10,500 |
| 16"        | 800                          | 1,000 | 1,850 | 2,900 | 4,600  | 7,500  | 10,600 | 13,500 |
| 18"        | 1,100                        | 1,400 | 2,450 | 3,800 | 5,000  | 9,700  | 13,850 | 18,000 |
| 20"        | 1,400                        | 1,650 | 3,050 | 4,800 | 7,400  | 12,500 | 17,750 | 23,000 |
| 24"        | 2,000                        | 2,400 | 4,200 | 6,600 | 10,500 | 17,000 | 23,000 | 31,000 |

## Torque Data

Torque is the rotary effort required to operate a valve. This turning force in a butterfly valve is determined by three factors – the friction of the disc and seat due to interference for sealing, bearing friction, and fluid dynamic torque.

### Breakaway torque at 70°F

Breakaway torque is the total of the torques resulting from bearing friction and disc/seat interference friction at a given pressure differential. Listed below are torques to open and close the valve at pressures shown in wet services (normal conditions).

Note: These values are valid for water and lubricating fluids only at 70°F. Since torques are greatly increased for dry and nonlubricating fluids and temperature variations, contact your Keystone representative for accurate values in these applications.

**Breakaway Torque in Inch Pounds for Wet Service Applications/Standard Disc**

| Line Pressure | Size |       |     |     |     |       |       |       |        |       |        |        |        |        |
|---------------|------|-------|-----|-----|-----|-------|-------|-------|--------|-------|--------|--------|--------|--------|
|               | 2    | 2 1/2 | 3   | 4   | 5   | 6     | 8     | 10    | 12     | 14    | 16     | 18     | 20     | 24     |
| 50            | 85   | 126   | 180 | 355 | 562 | 918   | 1,440 | 2,466 | 3,510  | 5,200 | 6,900  | 9,000  | 11,000 | 16,000 |
| 100           | 108  | 153   | 207 | 414 | 652 | 1,035 | 1,692 | 3,010 | 4,140  | 6,000 | 8,000  | 10,500 | 14,000 | 21,000 |
| 150           | 126  | 175   | 256 | 472 | 715 | 1,152 | 1,922 | 3,550 | 5,616  | 7,500 | 9,500  | 12,000 | 15,200 | 28,000 |
| 200           | 144  | 198   | 297 | 531 | 787 | 1,269 | 2,205 | 4,095 | 7,686  | 8,550 | 10,750 | 13,500 | 17,600 | 33,700 |
| 250           | 162  | 221   | 339 | 590 | 869 | 1,386 | 2,476 | 4,660 | 10,556 | –     | –      | –      | –      | –      |

## Materials Description

### Seats

**Food Grade EPDM** – Rated for temperatures -20°F to 250°F. Service conditions are equivalent to those recommended for regular EPDM including applications where Food Grade is required.

**NBR** – Rated for temperatures 0°F to 180°F. NBR is also commonly identified as BUNA-N, Nitrile, or Hycar®. It is an excellent general purpose elastomer suitable for use with air, water as well as most petroleum oils and greases, automotive gasolines (except those which have additives), alcohols and glycols, L-P gases, propane and butane, fuel oils and many other fluids. It also exhibits good abrasion resistance, and excellent resistance to compression set.

**Viton®** – Rated for temperatures 0°F to 300°F. Viton® is a DuPont Dow Elastomers trademark. Fluorel® is Dyneon's trademark for the equivalent fluorocarbon elastomer. This material offers higher temperature resistance and outstanding chemical resistance. It is resistant to hydrocarbon products and mineral acids, both diluted and concentrated solutions. However, it is never to be used in steam applications and is relatively poor in water service.

**Teflon®** – Rated for temperatures -20°F to 250°F. The Teflon® liner overlays silicone which is bonded to a rigid phenolic ring on the outside seat perimeter. Teflon® extends over the seat faces and outside flange seal diameter, completely covering the EPDM layer of the seat which provides the resilience for sealing valve stems and the closed disc.

### Special Valve Seats

**EPDM** – Rated for temperatures -20°F to 250°F. EPDM is an abbreviation of a compound called Ethylene Propylene Diene Monomer. It is also commonly called EPT, Nordel, and EPR. EPDM is used extensively in the HVAC (Heating, Ventilation, Air Conditioning) industry due to its resistance to polar compounds such as water, phosphate esters, ketones, alcohols, and glycols. The EPDM material is also applicable for handling concentrated sulfuric acid, 20% sodium hypochlorite (bleach), chlorinated water for swimming pools, and other alkaline solutions. EPDM is not resistant to hydrocarbon solvents and oils, chlorinated hydrocarbons, turpentine, or any other petroleum based oils.

**White Neoprene** – Rated for temperatures 0°F to 180°F. Neoprene has excellent resistance to alcohols,

glycols, dilute mineral acids, concentrated caustics, and aqueous salt solutions. White Neoprene is generally used in sanitary applications, and although it is slightly inferior to BUNA-N in oil resistance, it is markedly better than most elastomers in these applications.

**Black Neoprene** – Rated for temperatures 0°F to 180°F. Neoprene offers excellent physical properties where resistance to alcohols, glycols, dilute mineral acids, concentrated caustics, aqueous salt solutions, and mild abrasion resistance is required. The black grade provides better abrasion and oil resistance than the white grade Neoprene, and although it is slightly inferior to BUNA-N in oil resistance, it provides excellent service in water/oil, air/oil services.

**Hypalon®** – Rated for temperatures 0°F to 225°F. Hypalon® is the DuPont Dow Elastomers trademark for chlorosulfonated polyethylene. Hypalon® is resistant to most chemicals and greases and is particularly unaffected by aqueous salt solutions, alcohols, weak and concentrated alkalies, and concentrated sulfuric acid. It is not recommended for gasoline, jet fuels, ketones, or chlorinated solvents. Hypalon® has excellent abrasion resistance and is unaffected by prolonged immersion in water.

### Disc Coatings

**PVDF Coated Disc** – Rated for temperatures -20°F to 275°F. Polyvinylidene fluoride also known as Kynar® is a strong, tough fluoroplastic material that is particularly suited to corrosion resistant applications in severe environments. The coating has a high degree of mechanical strength, and is chemically resistant to most acids and bases over a broad temperature range. (min. thickness 20 mils).

**EPDM Coated Disc** – Rated for temperatures -20°F to 250°F. EPDM coated disc provides excellent wear and abrasion characteristics for use in highly abrasive environments. The EPDM elastomer also provides the disc with chemical resistance for handling certain acids, esters, ketones and all types of water service where normal metal discs cannot be used due to chemical and/or abrasive conditions. The EPDM coated discs are not recommended for use in hydrocarbon solvents and oils, chlorinated hydrocarbons, turpentine, or any other petroleum based oils. Other rubber materials available upon request.

#### Notes:

- A. Phenolic reinforced seats standard on 2" to 24"
- B. Letter identification of phenolic reinforced liners on I.D. of liner is:
  - NB = NBR
  - EM = Food-Grade EPDM
  - CF = White Neoprene
  - EP = EPDM
  - FK = Viton®
  - CR = Black Neoprene
  - CS = Hypalon®

## Valve Weights

### Wafer Body (lbs)

| Valve Size: | 2  | 2.5 | 3  | 4  | 5  | 6  | 8  | 10 | 12  | 14  | 16  | 18  | 20  | 24  |
|-------------|----|-----|----|----|----|----|----|----|-----|-----|-----|-----|-----|-----|
| Bare Stem   | 5  | 6   | 7  | 17 | 19 | 29 | 36 | 58 | 87  | 140 | 177 | 222 | 347 | 465 |
| Lever OP    | 10 | 11  | 12 | 22 | 24 | 34 | 41 | 63 | 92  | –   | –   | –   | –   | –   |
| Gear OP     | 14 | 15  | 19 | 24 | 30 | 32 | 62 | 84 | 130 | 164 | 201 | 246 | 371 | 535 |

### Lug Body (lbs)

| Valve Size: | 2  | 2.5 | 3  | 4  | 5  | 6  | 8  | 10  | 12  | 14  | 16  | 18  | 20  | 24  |
|-------------|----|-----|----|----|----|----|----|-----|-----|-----|-----|-----|-----|-----|
| Bare Stem   | 8  | 10  | 11 | 15 | 27 | 31 | 44 | 64  | 120 | 156 | 226 | 266 | 412 | 495 |
| Lever OP    | 13 | 15  | 16 | 20 | 32 | 36 | 49 | 69  | 125 | –   | –   | –   | –   | –   |
| Gear OP     | 17 | 19  | 20 | 27 | 40 | 44 | 79 | 115 | 163 | 180 | 250 | 290 | 436 | 565 |

### Material Specifications – ASTM References

| Part            | Material                      | Specs                 |
|-----------------|-------------------------------|-----------------------|
| <b>Body</b>     | Cast Iron                     | A126 Class B          |
|                 | Ductile Iron (2" to 12")      | A395 Grade 60/40/18   |
|                 | Ductile Iron (14" to 24" Lug) | A536 Grade 65/45/12   |
|                 | Stainless Steel               | A351 Grade CF8M       |
| <b>Disc</b>     | Ductile Iron                  | A236 Grade 65/45/12   |
|                 | Stainless Steel               | A351 Grade CF8M       |
|                 | Aluminum Bronze               | B148 UNS C945000      |
| <b>Stem</b>     | 416 SS                        | A582 Type 416         |
|                 | 316 SS                        | A276 Type 316 Cond. A |
| <b>Bearings</b> | Teflon®                       | Gar-Fil®              |

**Series 60 Ordering Information**

**Example:**

a 4" lug style with cast iron body, aluminum bronze U/C disc, 416 SS shaft and NBR seat with handle – **040 60L CAS2 U 1**

**040 60 L C A S 2 U 1**

**Size**

|              |           |
|--------------|-----------|
| 020 – 2"     | 100 – 10" |
| 025 – 2 1/2" | 120 – 12" |
| 030 – 3"     | 140 – 14" |
| 040 – 4"     | 160 – 16" |
| 050 – 5"     | 180 – 18" |
| 060 – 6"     | 200 – 20" |
| 080 – 8"     | 240 – 24" |

**Series**

60

**Body Style**

- W – Wafer
- L – Lug

**Body Material**

- C – Cast Iron (14" and larger wafer style available only in Cast Iron)
- D – Ductile Iron (14" and larger lug style available only in Ductile Iron)
- S – Stainless Steel (available only in 2" to 6" sizes)
- X – Other

**Disc Material**

- S – 316 Stainless Steel (2" to 12" valves with 316 SS Disc are available only with 316 SS Stem)
- A – Aluminum Bronze
- D – Ductile Iron – ENP
- E – EPDM coated
- N – NBR coated
- X – Other

**Stem Material**

- S – 416 Stainless Steel (standard)
- P – 316 Stainless Steel (optional; available only in 2" to 12" sizes)
- X – Other

**Seat Material**

|                       |                    |
|-----------------------|--------------------|
| 1 – EPDM (Food Grade) | 6 – Black Neoprene |
| 2 – NBR               | 7 – Teflon®        |
| 3 – Viton®            | 8 – EPDM           |
| 4 – Black Hypalon®    | X – Other          |
| 5 – White Neoprene    |                    |

**Special**

- U – U/C
- S – Silicone-free
- C – Sanitary Service (available only with Stainless Steel Body)
- X – Other

**Actuation**

|                         |                             |
|-------------------------|-----------------------------|
| 0 – None                | 4 – Pneumatic Direct Acting |
| 1 – 10 Position Handles | 5 – Pneumatic Spring Return |
| 2 – Gear                | 6 – Electric                |
| 3 – Chain Wheel         | X – Other                   |

## Additional Keystone Products



**Keystone K-LOK®** ANSI rated high performance valves are available in ASME 150 and ASME 300 pressure classes. They are available in a variety of trims to meet your higher pressure higher temperature requirements.



**Keystone Figure 106** large diameter butterfly valves are offered in sizes 24" to 48" for your larger diameter valve requirements.

**Tyco Flow Control** offers a complete line of actuation and controls to meet all your automation needs. This allows us to supply a complete package for single source responsibility.



**Keystone  
MRP Pneumatic Rack and  
Pinion Actuators**



**Keystone  
EPI<sub>2</sub> Electric Actuator**

[www.keystonevalves.com](http://www.keystonevalves.com)

Tyco Flow Control (TFC) provides the information herein in good faith but makes no representation as to its comprehensiveness or accuracy. This data sheet is intended only as a guide to TFC products and services. Individuals using this data sheet must exercise their independent judgment in evaluating product selection and determining product appropriateness for their particular purpose and system requirements. TFC MAKES NO REPRESENTATIONS OR WARRANTIES, EITHER EXPRESS OR IMPLIED, INCLUDING WITHOUT LIMITATION ANY WARRANTIES OF MERCHANTABILITY OR FITNESS FOR A PARTICULAR PURPOSE WITH RESPECT TO THE INFORMATION SET FORTH HEREIN OR THE PRODUCT(S) TO WHICH THE INFORMATION REFERS. ACCORDINGLY, TFC WILL NOT BE RESPONSIBLE FOR DAMAGES (OF ANY KIND OR NATURE, INCLUDING INCIDENTAL, DIRECT, INDIRECT, OR CONSEQUENTIAL DAMAGES) RESULTING FROM THE USE OF OR RELIANCE UPON THIS INFORMATION. Patents and Patents Pending in the U.S. and foreign countries. Tyco reserves the right to change product designs and specifications without notice. All registered trademarks are the property of their respective owners. Printed in the USA.