



Capilube Machined type Needle Roller bearing is newly available.

# Capilube Bearings with solid lubricant oil Machined type Needle Roller bearings and Cam Followers



CAT-5943



# Capilube Bearings with solid

**IKO** Capilube bearings are bearings that are pre-packed with thermosetting solid lubricant (Capilube) in the bearing space. Capilube is a lubricant made by thermosetting a large amount of oil and fine particles of ultra high molecular weight polyolefine resin. As the bearing rotates, the lubricating oil oozes out onto the raceway in proper quantity, keeping the lubrication performance for a long period of time.

## Feature of **IKO** Capilube bearings

### Maintenance work can be reduced greatly

Work for lubrication control can be reduced by a good lubrication performance kept by pre-packed solid type lubricant.

### Best suit for oil free environment applications

No oil scattering makes any pollution in the ambient environment.

### Best remedy for grease loss

Best solution for grease loss at hard-to-grease positions by the restriction of machine/equipment structure.

## Capilube Machined type Needle Roller bearings

Many needle rollers are arranged at a small spacing pitch, and can make bearing sectional height very low. It is the most suitable to oscillating motions.

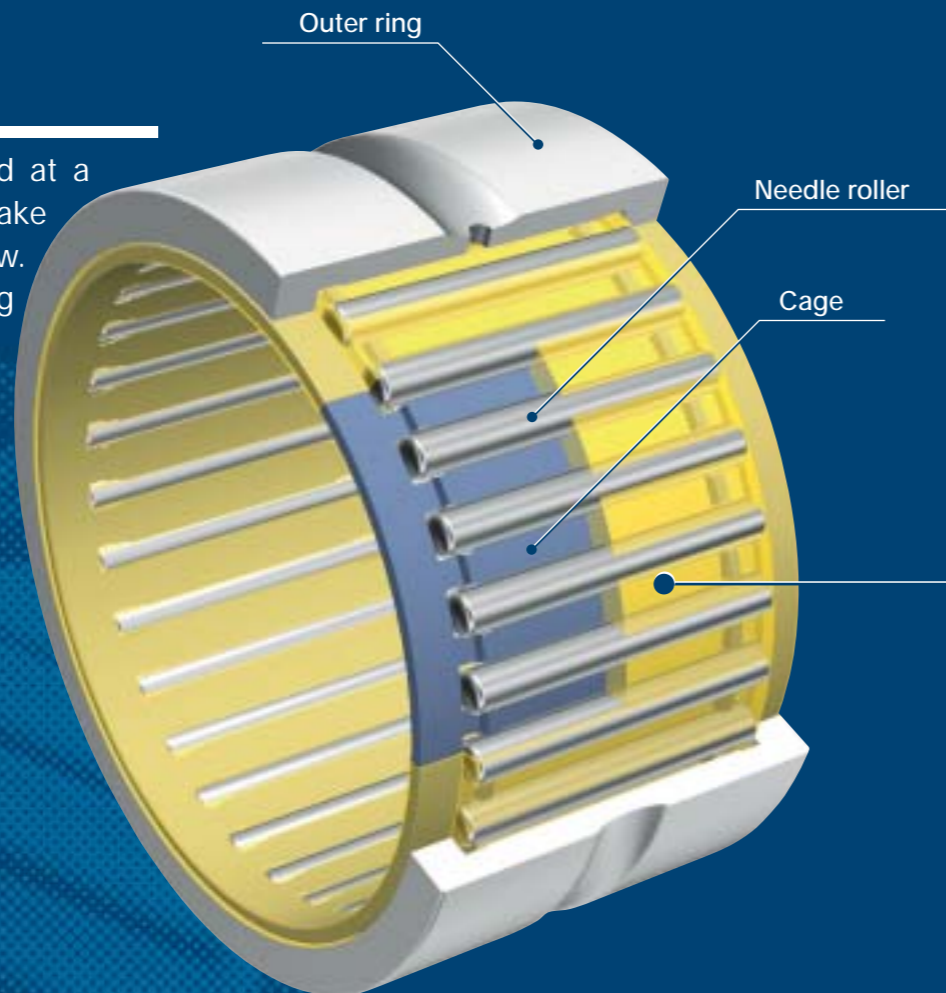

# lubricant oil

## Applications

Most suitable for applications of printing machines, food-manufacturing machines, liquid crystal/semiconductor manufacturing equipment, various types of washing line, various types of transport lines, etc.

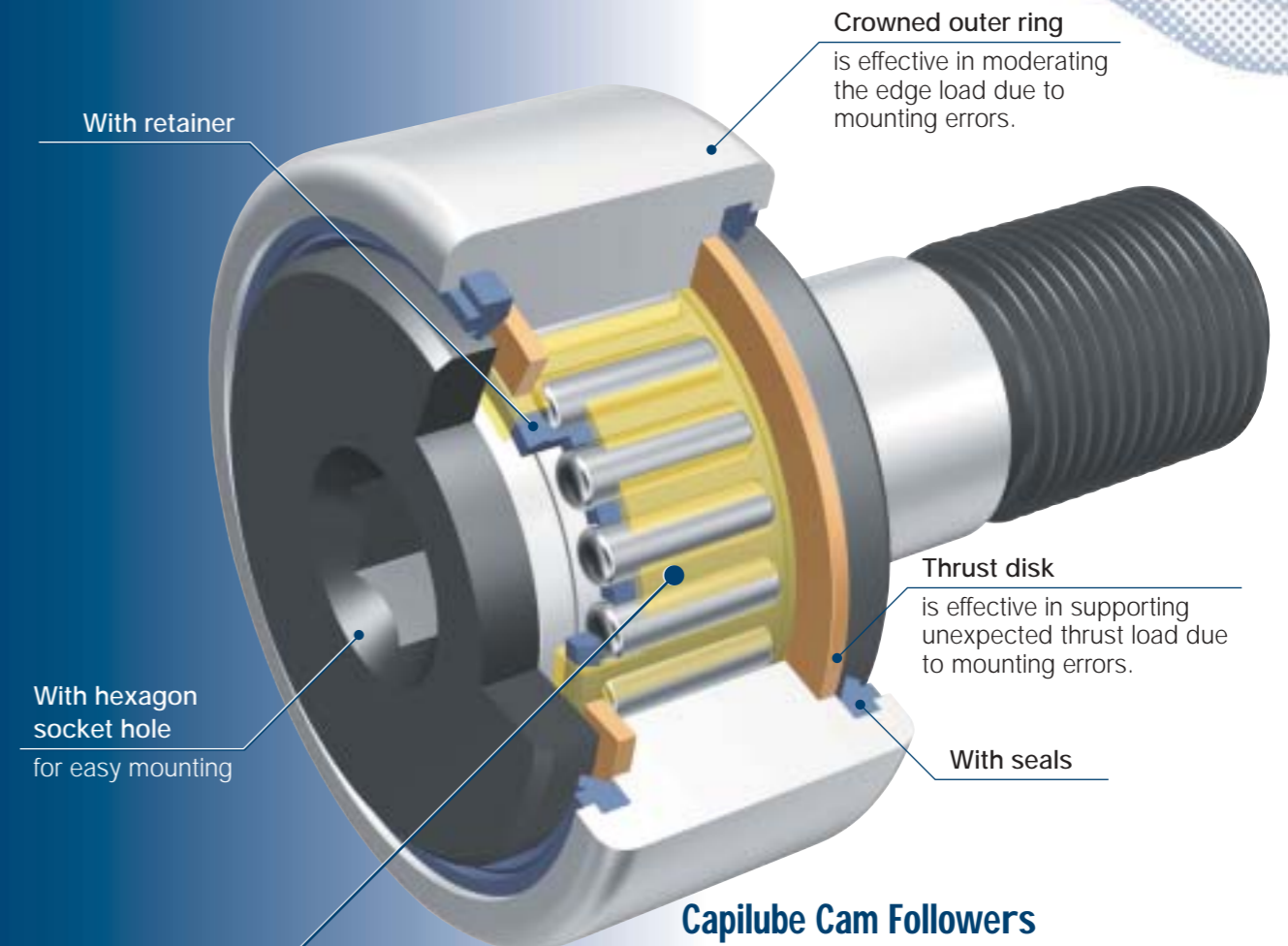

## Capilube Cam Followers

Cam Follower is the best bearing for cam mechanism and linear motion and has high rigidity and high accuracy.

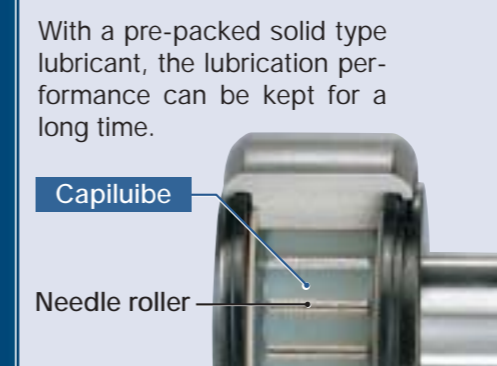



## [ Capilube Bearings with solid lubricant oil ] Machined type Needle Roller bearings

IKO Capilube Machined type Needle Roller bearing is a needle roller bearing that is pre-packed with thermosetting solid lubricant (Capilube) in the bearing space. As the bearing rotates, the lubricating oil oozes out onto the raceway in proper quantity, keeping the lubrication performance for a long period of time.

With a low sectional height, it can have large load ratings.

Machined outer ring has superior rigidity and can be fitted into light alloy housing.

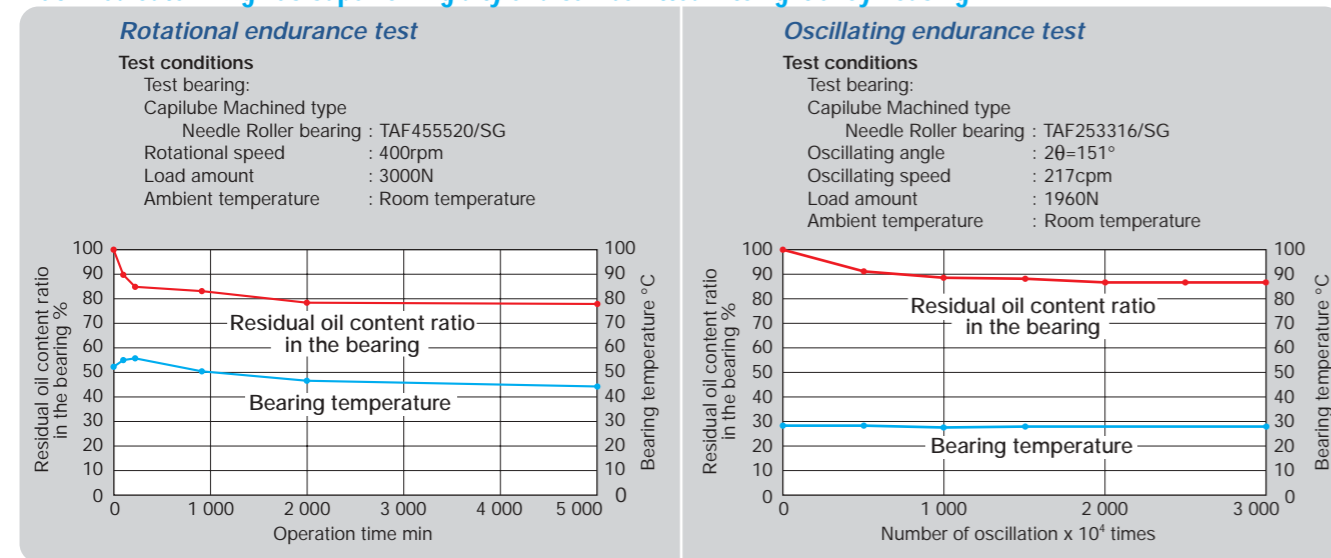

### Identification number

The identification number example of IKO Capilube Machined type Needle Roller bearing is shown.

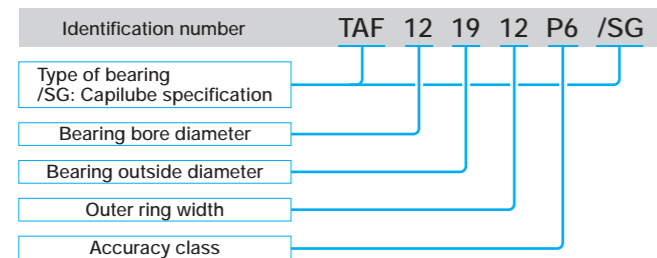

### Basic dynamic load rating

The basic dynamic load rating is defined as the constant radial load acting along the bearing central axis that allows a basic rating life of 1,000,000 revolutions.

### Basic static load rating

The basic static load rating is the static load that gives the contact stress reaches 4,000Mpa at the center of the contact area of the rolling elements and the raceway receiving the maximum load.

### Accuracy

The accuracy of IKO Capilube Machined type Needle Roller bearings conforms to JIS B 1514:2000 (Tolerances of Rolling Bearings), and the dimensional accuracy and rotational accuracy are specified. Representative tolerances of outer ring are shown in Table 1 and the tolerances for the smallest single roller set bore diameter is shown in Table 2.

Table 1 Tolerance for outer ring

D Nominal bearing outside diameter mm	$\Delta D_{mp}$ Single plane mean outside diameter deviation								$\Delta C_s$ Deviation of a single outer ring width							
	Class 0		Class 6		Class 5		Class 4		Class 0		Class 6		Class 5		Class 4	
	High	Low	High	Low	High	Low	High	Low	High	Low	High	Low	High	Low	High	Low
18	22	0	-9	0	-8	0	-6	0	-5	0	-120	-120	0	-40	0	-40
22	30	0	-9	0	-8	0	-6	0	-5	0	-120	-120	0	-80	0	-80
30	50	0	-11	0	-9	0	-7	0	-6	0	-120	-120	0	-120	0	-120
50	80	0	-13	0	-11	0	-9	0	-7	0	-120	-120	0	-120	0	-120

Table 2 Tolerances for the smallest single roller set bore diameter  $F_{ws \min}^{(1)}$

$F_w$ Nominal roller set bore diameter mm	$\Delta F_{ws \min}$ Deviation of the smallest single roller set bore diameter $\mu m$	
	Over	Incl.
10	18	+27
18	30	+33
30	45	+41

Note (1): This is the diameter of the cylinder used instead of the inner ring, where the radial clearance becomes zero at least in one radial direction.

### Design of shaft and housing

IKO Capilube Machined type Needle Roller bearings does not have inner ring so that the shaft can be used directly as the raceway surfaces. Shaft and housing according to specification in Table 3 are recommended.

Table 3 Specification of shaft and housing

Item	Shaft	Housing
Roundness	$0.3 \times IT6^{(1)}$ or $0.3 \times IT5^{(1)}$	$0.3 \times IT7^{(1)}$ or $0.3 \times IT6^{(1)}$
Cylindricity	$0.3 \times IT6^{(1)}$ or $0.3 \times IT5^{(1)}$	$0.5 \times IT7^{(2)}$ or $0.5 \times IT6^{(2)}$
Surface roughness	$0.2 \mu m R_a^{(3)}$	$1.6 \mu m R_a$
Hardness	58 ~ 64HRC <sup>(4)</sup>	-

Note (1): 30% or less of the dimensional tolerance for the shafts or housing bores is recommended.

(2): 50% or less of the dimensional tolerance for shafts or housing bores is recommended.

(3): When required accuracy is not critical, a surface roughness within  $0.8 \mu m R_a (3.2 \mu m R_z)$  is allowable.

(4): An appropriate depth of the hardened layer is required.

### Allowable rotational speed

The allowable rotational speeds of IKO Capilube Machined type Needle Roller bearings are affected by mounting and operating conditions. Recommended  $d_{mn}$  value<sup>(1)</sup> is less than 20,000 under pure radial load condition. Under actual usage,  $d_{mn}$  value is recommended to be less than 2,000 due to unexpected axial load.

Note (1):

Value  $d_{mn} = (\text{Bearing bore dia. [mm]} + \text{Bearing outside dia. [mm]}) / 2 \times \text{Number of revolution [rpm]}$

### Fit

The recommended fits for IKO Capilube Machined type Needle Roller bearings are shown in Table 4 to 5.

Table 4 Fit between IKO Capilube Machined type Needle Roller bearings and housings

Load condition	Tolerance class of housing	
	Normal load	Light load, Fluctuating load
Rotating load on outer ring	N 7 <sup>(1)</sup>	M 7
Directionally indeterminate load	Normal load	K 7
	Light load, normal load	J 7
Stationary load on outer ring	Light load, normal load	H 7
	With heat conduction through shaft	G 7
With light or normal load, especially accurate rotation and high rigidity are required.		K 6

Note (1): Care should be taken so that the radial internal clearance is not too small.

Remark 1: This table applies to steel or cast iron housings. For lighter metal, a tighter fit should be selected. For split housings, do not use a fit tighter than J7.

2: Light load and normal load represent  $P < 0.06C$  and  $0.06C < P < 0.12C$ , respectively, where  $P$  is the dynamic equivalent radial load and  $C$  is the basic dynamic load rating of the bearing to be used.

Table 5 Tolerance of the shafts

Radial internal clearance	Tolerance class of shaft
Smaller than CN clearance	k 5
CN clearance	h 5
Larger than CN clearance	g 6

Remark: When the housing bore fit is tighter than K7, the shaft diameter is made smaller by considering shrinkage of roller set bore diameter after mounting.

### Mounting

- Mounting dimension for IKO Capilube Machined type Needle Roller bearings are shown in the dimension table.
- When mounting IKO Capilube Machined type Needle Roller bearings, pay attention to avoid locating the oil hole of the inner ring within the loading zone. This may lead to a short bearing life.

### Caution for use

- Never wash bearing with organic solvent and/or white kerosene, which have the ability to remove fat.
- To ensure normal rotation of the bearing, apply a load of 1% or more of the dynamic load rating at use.
- The operating temperature range is -15 to +80°C. For continuous operation, the recommended operating temperature is +60°C or less.
- When using two or more IKO Capilube Machined type Needle Roller bearings adjacent to each other on the same shaft, it is necessary to obtain an even load distribution. On request, a set of bearings is available, in which bearings are matched to obtain an even load distribution.

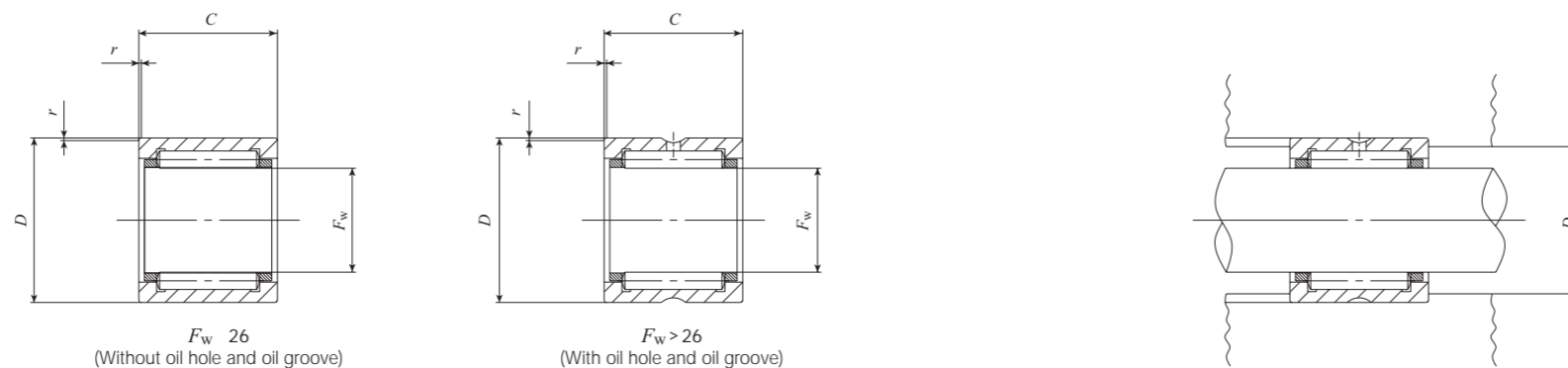

Shaft dia. mm	Identification number	Mass (Reference) g	Boundary dimensions mm				$r_{s \min}^{(1)}$	Standard mounting dimension $D_a$ Max. mm	Basic dynamic load rating C N	Basic static load rating $C_0$ N	Identification number
			$F_w$	D	C						
12	TAF 121912/SG	12.5	12	19	12	0.3	17	6 610	7 260	TAF 121912/SG	
	TAF 121916/SG	16.8	12	19	16	0.3	17	9 250	11 200	TAF 121916/SG	
15	TAF 152316/SG	23.5	15	23	16	0.3	21	12 300	14 900	TAF 152316/SG	
	TAF 152320/SG	29	15	23	20	0.3	21	15 600	20 200	TAF 152320/SG	
18	TAF 182616/SG	26.5	18	26	16	0.3	24	13 400	17 500	TAF 182616/SG	
	TAF 182620/SG	33	18	26	20	0.3	24	17 000	23 600	TAF 182620/SG	
20	TAF 202816/SG	28.5	20	28	16	0.3	26	13 900	18 800	TAF 202816/SG	
	TAF 202820/SG	37	20	28	20	0.3	26	17 600	25 400	TAF 202820/SG	
22	TAF 223016/SG	31	22	30	16	0.3	28	14 900	21 200	TAF 223016/SG	
	TAF 223020/SG	39	22	30	20	0.3	28	18 900	28 700	TAF 223020/SG	
25	TAF 253316/SG	35	25	33	16	0.3	31	15 800	23 700	TAF 253316/SG	
	TAF 253320/SG	43.5	25	33	20	0.3	31	20 000	32 100	TAF 253320/SG	
30	TAF 304020/SG	67	30	40	20	0.3	38	25 100	40 100	TAF 304020/SG	
	TAF 304030/SG	101	30	40	30	0.3	38	36 000	63 900	TAF 304030/SG	
45	TAF 455520/SG	95.5	45	55	20	0.3	53	31 000	60 200	TAF 455520/SG	
	TAF 455530/SG	144	45	55	30	0.3	53	44 600	95 800	TAF 455530/SG	

Note (1) : Minimum allowable value of chamfer dimension r.

1N 0.102kgf

Remark : Bearing with a roller set bore diameter  $F_w$  of 26mm or less have no oil hole and oil groove. In others, the outer ring has an oil hole and an oil groove.

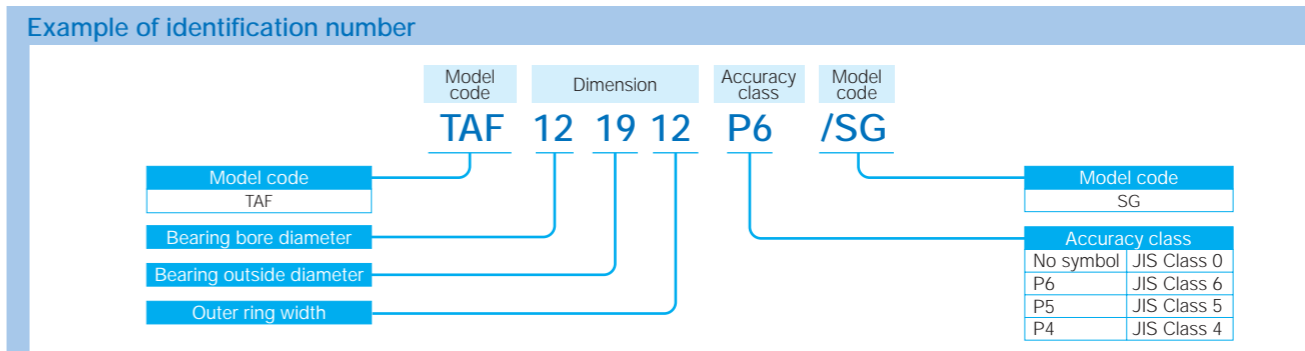

# IKO Maintenance free Needle Roller bearing series

## [ Pre-packed with solid type lubricant ] Capilube Cam Followers

Cam Follower is bearing with a stud incorporating needle rollers in a thick walled outer ring. It has high rigidity and high accuracy and is suitable to cam and linear motion mechanisms.

IKO Capilube Cam Follower is a Cam Follower that is pre-packed with thermosetting solid lubricant (Capilube) in the bearing space.

The lubrication effect can be maintained in long time operation.  
It contributes to "Maintenance free".

### Rotational endurance test

Test condition  
Test product  
IKO Capilube Cal Follower: CF10/SG  
IKO Standard Cam Follower: CF10  
Rotational speed : 1,000rpm  
Ambient temperature : Room temperature

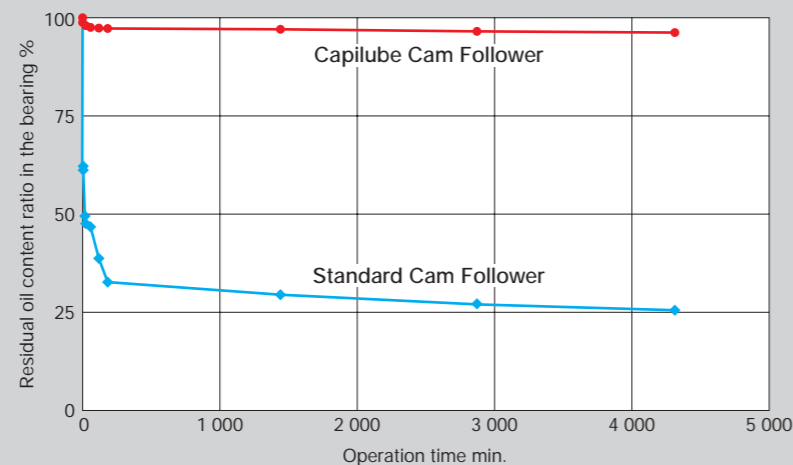

### Identification number

An example of identification number of IKO Capilube Cam Follower is shown.

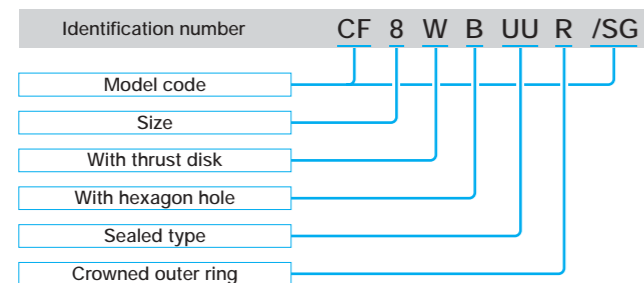

### Basic dynamic load rating

The basic dynamic load rating is defined as the constant radial load acting along the bearing central axis that allows a basic rating life of 1,000,000 revolutions.

### Basic static load rating

The basic static load rating is the static load that gives the contact stress reaches 4,000Mpa at the center of the contact area of the rolling elements and the raceway receiving the maximum load.

### Maximum Allowable Load

The applicable load on IKO Capilube Cam Follower is, in some cases, limited by the bearing strength, shear strength of stud, and strength of outer ring instead of the load rating of needle roller bearing, because the IKO Capilube Cam Follower is mounted in a cantilever position. Maximum allowable loads limited by the bending strength and shear strength.

### Track capacity

The capacity is defined as the load which can be continuously applied on a IKO Capilube Cam Follower placed on a steel track surface without causing deformation and indentation (dent) on the track surface.

### Accuracy

The accuracy of IKO Capilube Cam Follower is shown in Table 6. And the radial run-out of the outer ring is controlled 15µm in maximum.

	Outside diameter of outer ring $D$	Stud diameter $d_1$	Width of outer ring $C$
Tolerances	0 -50	h7	0 -120

### Clearance

The radial internal clearances of IKO Capilube Cam Follower are shown in Table 7.

Identification number	Radial internal clearance	
	Min.	Max.
CF 6 WBUUR/SG	5	20
CF 8 WBUUR/SG CF 10 WBUUR/SG CF 10-1 WBUUR/SG CF 12 WBUUR/SG CF 12-1 WBUUR/SG	5	25

Remark: Values are applicable before the solid type lubricant is packed.

### Fit

Mounting hole tolerance for stud is recommended to be H7 for IKO Capilube Cam Followers. In case it is supported in a cantilever position, the mounting hole diameter should be prepared without play between the stud and the mounting hole especially when heavy shock loads are applied.

### Allowable rotational speed

The allowable rotational speeds of IKO Capilube Cam Follower are affected by mounting and operating conditions. Recommended  $d_1n$  value <sup>(1)</sup> is less than 10,000 under pure radial load condition. Under actual usage,  $d_1n$  value is recommended to be less than 1,000 due to unexpected axial load.

Note <sup>(1)</sup>:  
Value  $d_1n = d_1$  (Stud diameter [mm])  $\times$   $n$  (Number of revolution [rpm])

### Mounting

1. Make the center axis of the mounting hole perpendicular to the moving direction of the IKO Capilube Cam Follower and match the side shoulder accurately with the seating surface indicated by dimension  $f$  in the table of dimensions. Then, fix the Cam Follower with the nut. Do not hit the flange head of the IKO Capilube Cam Follower directly with a hammer, etc. This may lead to a bearing failure such as irregular rotation or cracking.
2. The IKO mark on the flange head of the stud indicates the oil hole position on the raceway. Avoid locating the oil hole within the loading zone which may lead to a short bearing life. (See Fig.1)

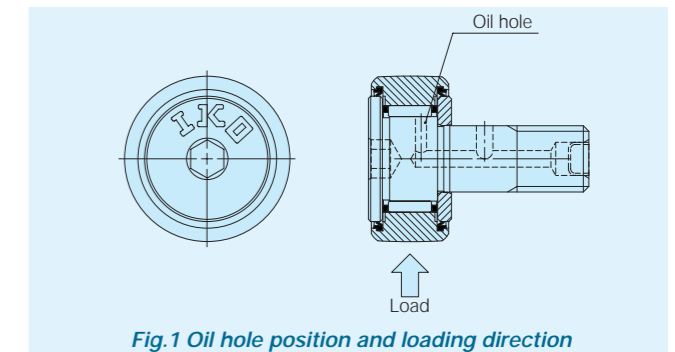

3. When tightening the nut, the tightening torque should not exceed the value shown in the dimension table. If the tightening torque is too large, it is possible that the threaded portion of the stud will be broken. When there is a possibility of loosening, a special nut such as lock nut, spring washer, or self-locking nut should be used.

### Caution for use

1. Never wash bearing with organic solvent and/or white kerosene, which have the ability to remove fat.
2. To ensure normal rotation of the bearing, apply a load of 1% or more of the dynamic load rating at use.
3. The operating temperature range is -15 to +80°C. For continuous operation, the recommended operating temperature is +60°C or less.
4. When the lubricant status is not enough between the outer ring and the mating track surface, seizure or wear may be occurred depending on the operating conditions. In particular, care must be taken for lubricating condition and contacting surface roughness in case high-speed cam mechanisms.

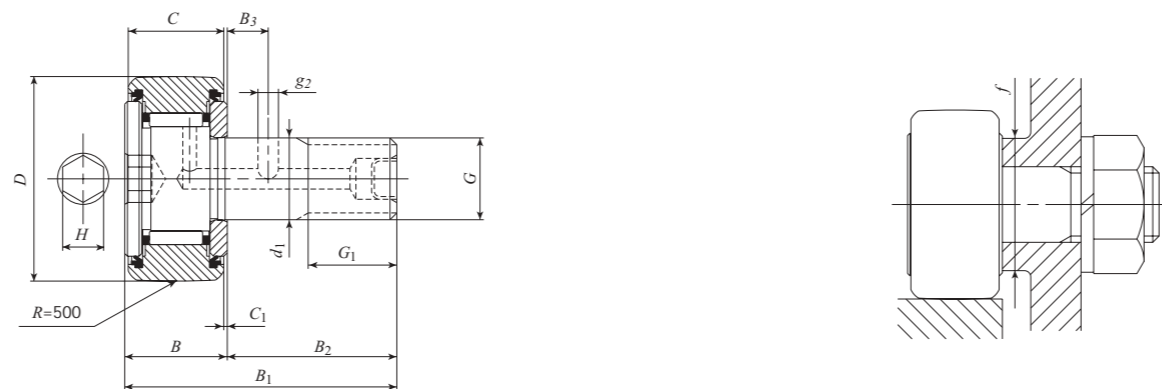

Stud dia. mm	Identification number	Mass (Reference) g	Boundary dimension mm											Mounting dimension f Min. mm	Maximum tightening torque N·m	Basic dynamic load rating C N	Basic static load rating C <sub>0</sub> N	Maximum allowable load N	Track capacity <sup>(1)</sup> N	Identification number		
			D	C	d <sub>1</sub>	G	G <sub>1</sub>	B max.	B <sub>1</sub> max.	B <sub>2</sub>	B <sub>3</sub>	C <sub>1</sub>	g <sub>2</sub>								H	
6	CF 6 WBUUR/SG	18.5	16	11	6	M 6 × 1	8	12.2	28.2	16	-		0.6	-	3	11	2.7	3 660	3 650	1 950	1 040	CF 6 WBUUR/SG
8	CF 8 WBUUR/SG	28.5	19	11	8	M 8 × 1.25	10	12.2	32.2	20	-		0.6	-	4	13	6.5	4 250	4 740	4 620	1 330	CF 8 WBUUR/SG
10	CF 10 WBUUR/SG	45	22	12	10	M10 × 1.25	12	13.2	36.2	23	-		0.6	-	4	16	13.8	5 430	6 890	6 890	1 610	CF 10 WBUUR/SG
	CF 10-1 WBUUR/SG	60	26	12	10	M10 × 1.25	12	13.2	36.2	23	-		0.6	-	4	16	13.8	5 430	6 890	6 890	2 030	CF 10-1 WBUUR/SG
12	CF 12 WBUUR/SG	95	30	14	12	M12 × 1.5	13	15.2	40.2	25	6		0.6	3	6	21	21.9	7 910	9 790	9 790	2 470	CF 12 WBUUR/SG
	CF 12-1 WBUUR/SG	105	32	14	12	M12 × 1.5	13	15.2	40.2	25	6		0.6	3	6	21	21.9	7 910	9 790	9 790	2 710	CF 12-1 WBUUR/SG

Note <sup>(1)</sup> : Values in the table are applicable when the hardness of the mating track surface is 40HRC. When the hardness of the mating track surface differs from 40HRC, the track capacity is obtained by multiplying track capacity factor shown in Table 8.

1N 0.102kgf

Remark : Models with a stud diameter d<sub>1</sub> of 10mm or less has no oil hole. The others are provided with one oil hole each on the outside surface and end surface of the stud.

**Table 8 Track capacity factor**

Hardness HRC	Tensile strength N/mm <sup>2</sup>	Track capacity factor
20	760	0.22
25	840	0.31
30	950	0.45
35	1 080	0.65
38	1 180	0.85
40	1 250	1.00
42	1 340	1.23
44	1 435	1.52
46	1 530	1.85
48	1 635	2.27
50	1 760	2.80
52	1 880	3.46
54	2 015	4.21
56	2 150	5.13
58	2 290	6.26

**Example of identification number**

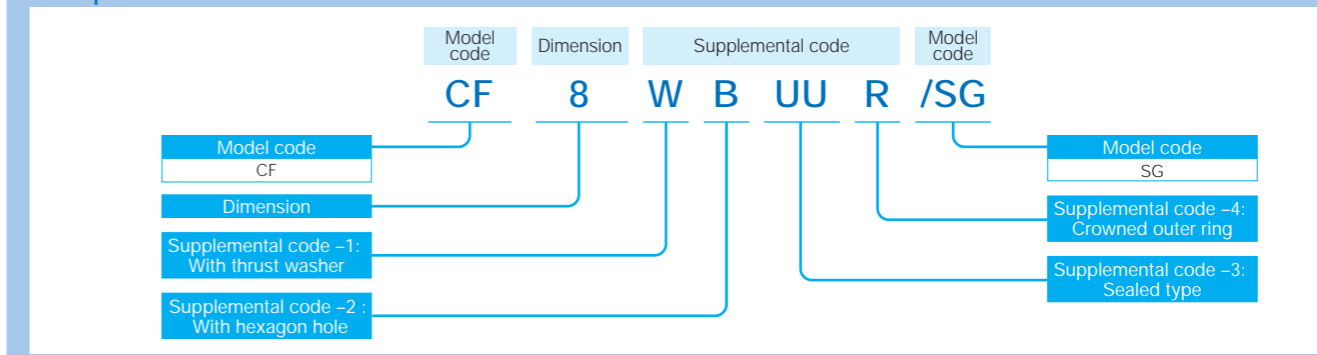



# Capilube Bearings



See you again at **IKO Website**  
<http://www.ikont.co.jp/eg/>

## **NIPPON THOMPSON CO., LTD.**

Head office : 19-19 Takanawa 2-chome  
Minato-ku, Tokyo 108-8586, Japan  
Phone : +81 (0)3-3448-5850  
Fax : +81 (0)3-3447-7637  
E-mail : [ntt@ikonet.co.jp](mailto:ntt@ikonet.co.jp)  
URL : <http://www.ikont.co.jp/eg/>  
Plant : Gifu, Kamakura

## **Nippon Thompson Co., Ltd.**

- ASEAN REPRESENTATIVE OFFICE  
586 Luang Road, Pomprab  
Pomprab Satrupai, Bangkok  
Thailand 10100  
Phone: +66 (0)-2623-3699  
Fax: +66 (0)-2623-0716  
E-mail: [iko@anet.net.th](mailto:iko@anet.net.th)
- CHINA REPRESENTATIVE OFFICE  
Shanghai Apollo Business Center 619  
1440 Yan An C. Road, Shanghai 200040  
People's Republic of China  
Phone: +86 (0)21-6248-1120  
Fax: +86 (0)21-6249-6835

## **IKO International, Inc.**

- 91 Walsh Drive  
Parsippany, NJ 07054  
U.S.A.  
Phone: +1 973-402-0254  
Toll Free: 1-800-922-0337  
Fax: +1 973-402-0441  
E-mail: [eco@ikonet.co.jp](mailto:eco@ikonet.co.jp)
- 500 East Thorndale Avenue  
Wood Dale, IL 60191  
U.S.A.  
Phone: +1 630-766-6464  
Toll Free: 1-800-323-6694  
Fax: +1 630-766-6869  
E-mail: [mwo@ikonet.co.jp](mailto:mwo@ikonet.co.jp)
- 20170 South Western Avenue  
Torrance, CA 90501  
U.S.A.  
Phone: +1 310-609-3988  
Toll Free: 1-800-252-3665  
Fax: +1 310-609-3916  
E-mail: [wco@ikonet.co.jp](mailto:wco@ikonet.co.jp)
- 2150 Boggs Road, Suite 100  
Duluth, GA 30096  
U.S.A.  
Phone: +1 770-418-1904  
Toll Free: 1-800-874-6445  
Fax: +1 770-418-9403  
E-mail: [seo@ikonet.co.jp](mailto:seo@ikonet.co.jp)
- 8105 N. Beltline Road  
Suite 130, Irving, TX 75063  
U.S.A.  
Phone: +1 972-929-1515  
Toll Free: 1-800-295-7886  
Fax: +1 972-915-0060  
E-mail: [sw0@ikonet.co.jp](mailto:sw0@ikonet.co.jp)

## **Nippon Thompson Europe B.V.**

- Sheffieldstraat 35-39  
3047 AN Rotterdam  
The Netherlands  
Phone: +31 (0)10-4626868  
Fax: +31 (0)10-4626099  
E-mail: [nte@ikonet.co.jp](mailto:nte@ikonet.co.jp)
- Mündelheimer Weg 56  
40472 Düsseldorf  
Germany  
Phone: +49 (0)211-414061  
Fax: +49 (0)211-427693  
E-mail: [ntd@ikonet.co.jp](mailto:ntd@ikonet.co.jp)  
Donaustauer Str. 200  
93059 Regensburg  
Germany  
Phone: +49 (0)941-447737  
Fax: +49 (0)941-447747  
Gruben Str.95c  
66540 Neunkirchen  
Germany  
Phone: +49 (0)6821-742535  
Fax: +49 (0)6821-742536
- 2 Vincent Avenue, Crownhill  
Milton Keynes Bucks MK8 OAB  
United Kingdom  
Phone: +44 (0)1908-566144  
Fax: +44 (0)1908-565458  
E-mail: [sales@iko.co.uk](mailto:sales@iko.co.uk)
- Autovia Madrid-Barcelona, Km. 43,700  
Polig. Ind. AIDA, A-8, Ofic. 2, 1<sup>a</sup>  
19200-Azuqueca de Henares  
Guadalajara, Spain  
Phone: +34 949-263390  
Fax: +34 949-263113  
E-mail: [nts@ikonet.co.jp](mailto:nts@ikonet.co.jp)
- Roissypole Le Dôme  
2 rue de La Haye  
BP 10950 Tremblay en France  
95733 Roissy C. D. G. Cedex  
France  
Phone: +33 (0)1-48165739  
Fax: +33 (0)1-48165746  
E-mail: [ntf@ikonet.co.jp](mailto:ntf@ikonet.co.jp)

Although all data in this catalog has been carefully compiled to make the information as complete as possible, NIPPON THOMPSON CO., LTD. shall not be liable for any damages whatsoever, direct or indirect, based upon any information in this catalog. NIPPON THOMPSON CO., LTD. makes no warranty, either express or implied, including the implied warranty of merchantability or fitness for a particular purpose.