

ISO 9001:2008 by L.R.
PED DIR. 97/23/EC by L.R.
ATEX DIR. 94/9/EC by B.V.
FIRE SAFE EXECUTION by L.R.
ISO 15848 by TÜV
ANTISTATIC DEVICE by L.R.
FIRE SAFE TESTED ISO 10497 by L.R.

TYPE
FA8
PN 10 ÷ 16

NORME E DIRETTIVE APPLICATE DISPONIBILI AL SEGUENTE LINK:
STANDARD AND DIRECTIVE APPLIED AVAILABLE AT FOLLOWING LINK:
http://www.adlerspa.com/pdf/NORME_ADLER.pdf

VALVOLE A SFERA "CORPO PIATTO" PASSAGGIO TOTALE MONTAGGIO DI FONDO

ISO nbr° LRC 0160281 QMS issued by L.R.Q.A. PED nbr° COV 0212112/01 issued by L.R.V.
ATEX nbr° 40.2003.4392 issued by B.V. ISO 15848 nbr° I-148466/1-/2 issued by TÜV

FULL BORE ACCORDING
TO ISO 14313

On request
S.I.L. 3
According to IEC 61508

On request
FIRE SAFE
According to ISO 10497
"ISO-FT"

CONSTRUCTION ACCORDING TO:
BS EN 12516-2 - ANSI B16.34
ISO 14313

**BALL VALVES "WAFER TYPE" FULL BORE END TANK
ASSEMBLING**

**ROBINETS A BOISSEAU SPHERIQUE "WAFER"
PASSAGE INTEGRAL MONTAGE FOND DE CUVE
FLANSCHKUGELHÄHNE IN "KOMPAKTBAUWEISE"
VOLLER DURCHGANG EINBAU ALS
BODENABLASSKUGELHAHN**

WEB SITE: WWW.ADLERSPA.COM

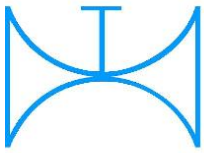

ISO 9001:2008 by L.R.
 PED DIR. 97/23/EC by L.R.
 ATEX DIR. 94/9/EC by B.V.
 FIRE SAFE EXECUTION by L.R.
 ISO 15848 by TÜV
 ANTISTATIC DEVICE by L.R.
 FIRE SAFE TESTED ISO 10497 by L.R.

TYPE
FA8
 PN 10 ÷ 16

VALVOLA A SFERA "CORPO PIATTO" PASSAGGIO TOTALE, MONTAGGIO DI FONDO
 BALL VALVES "WAFER TYPE" FULL BORE, END TANK ASSEMBLING
 ROBINETS A BOISSEAU SPHERIQUE "WAFER" PASSAGE INTEGRAL, MONTAGE FOND DE CUVE
 FLANSCHKUGELHÄHNE IN "KOMPAKTBAUWEISE" VOLLER DURCHGANG,
 EINBAU ALS BODENABLASSKUGELHAHN

FLANGIA LATO SERBATOIO
 MAGGIORATA
 TANK SIDE FLANGE INCREASED

CONSTRUCTION
 ACCORDING TO:
 BS EN 12516-2
 ANSI B16.34
 ISO 14313

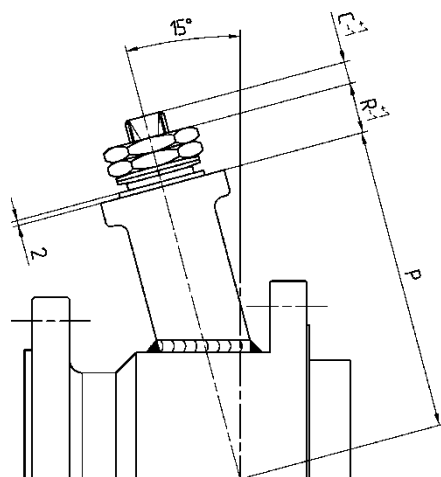
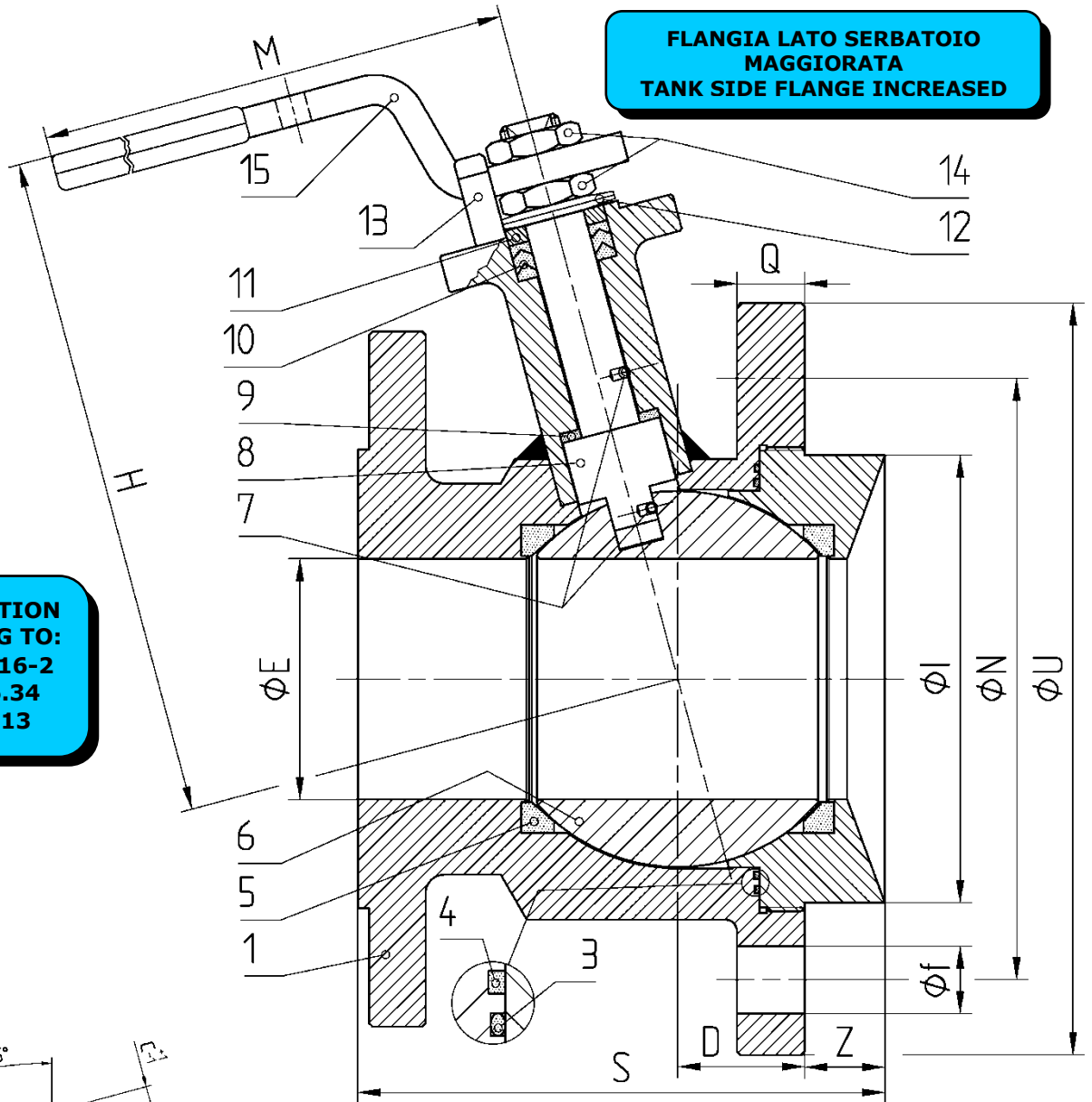

• ACCOPIAMENTO VALVOLA
 ATTUATORE
 • CONNECTION VALVE
 ACTUATOR
 • ACCOUPLEMENT ROBINET-
 ACTIONNEUR
 • ZUSAMMENBAU KUGELHAHN
 ANTRIEB
ISO-5211

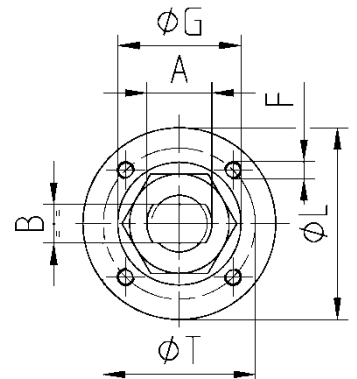

N.	DESCRIZIONE DESCRIPTION DESCRIPTION BESCHREIBUNG	MATERIALI MATERIALS MATERIAUX WERKSTOFFE
1	CORPO BODY CORPS KÖRPER	ASTM A479 316/316L
2	GHIERA INSERT EMBOUT GEWINDEDRUCKRING	ASTM A479 316/316L
3*	O-RING	FKM - (VITON)
4*	ANELLO SEAL ANNEAU DICHTUNGSRING	P.T.F.E.
5*	SEDE SEAT SIEGE SITZRING	P.T.F.E. (BAM CERTIFIED) R.P.T.F.E. (OPTIONAL)
6	SFERA BALL BOULE KUGEL	ASTM A479 316/316L ASTM A351 CF8M
7	DISPOSITIVO ANTISTATICO ANTISTATIC DEVICE CONTACT ANTISTATIQUE ANTISTATIK VORRICHTUNG	ASTM A479 316/316L
8	STELO STEM TIGE SPINDEL	ASTM A479 316/316L

N.	DESCRIZIONE DESCRIPTION DESCRIPTION BESCHREIBUNG	MATERIALI MATERIALS MATERIAUX WERKSTOFFE
9*	BUSSOLA STEM SEAL JOINT TIGE UNTERE SPINDELABDICHTUNG	P.T.F.E.
10*	PACCO A "V" CHEVRON RINGS JOINT A "V" 3 FACHE DACHMANSCHETTE	P.T.F.E. / GRAFITE P.T.F.E. / GRAPHITE P.T.F.E. / GRAPHITE P.T.F.E. / GRAPHIT
11	PREMIBUSSOLA PRESSING BUSH PRESSE RONDELLE STOPFBUCHSDRUCKRING	ASTM A479 304
12	MOLLE A TAZZA SPRING WASHERS RONDELLES BELLEVILLE TELLERFEDERN	C72/50Cr V ₄ X5CrNi17.7 or X12CrNi17.7 ZINCATO - GALVANIZED - ZINGUE - VERZINKT ON REQUEST
13	VITE DI FERMO E FERMO PIN AND STOP PIN PLONT ET PLOT D'ARRET ANSCHLAGBOLZEN	UNI 3740 8.8 UNI 3951 A2-70 ZINCATO - GALVANIZED - ZINGUE - VERZINKT ON REQUEST
14	DADO - CONTRODADO NUT - LOCK NUT ECROU - CONTRE-ECROU MUTTER - KONTERMUTTER	UNI 3740 - 6S ASTM A479 304 ZINCATO - GALVANIZED ZINGUE - VERZINKT ON REQUEST
15	LEVA WRENCH LEVIER HANDHEBEL	AISI 1010 ASTM A479 304 ZINCATO - GALVANIZED ZINGUE - VERZINKT ON REQUEST
16		

* RICAMBI CONSIGLIATI - RECOMMENDED SPARE PARTS - PIÈCES DE RECHANGE CONSEILLÉES - ERSATZTEIL EMPFEHLUNG

DIMENSIONI - DIMENSION - DIMENSIONS - ABMESSUNGEN

DN	10	15	20	25	32	40	50	65	80	100	125	150	200	250	300
AxB							16x10	16x10	22x14	30x18					
C							9	9	18	18					
D							27,5	33,7	38,5	49,1					
E							51	64	76	94					
F							M6	M6	M8	M8					
f							18	18	18	18					
ISO							F05	F05	F07	F07					
G							35	35	55	55					
H							175	179	194	230					
I							94	119	138	165					
L							64	64	90	90					
M							280	280	370	470					
N							145	160	180	210					
P							120	125	137	157.5					
Q							20	18	18	22					
R							20	20	19	26					
S							130	140	160	200					
T							50	50	70	70					
U							185	199	220	250					
Z							17,5	21,3	20,2	28,5					
~Kg							12	15	19	29					

- DATI E CARATTERISTICHE SOGGETTI A VARIAZIONI SENZA PREAVVISO
- SPECIFICATIONS SUBJECT TO MODIFICATION WITHOUT PRIOR NOTICE
- TOUS DROITS DE MODIFICATION RESERVES
- KONSTRUKTIONÄNDERUNGEN VORBEHALTEN



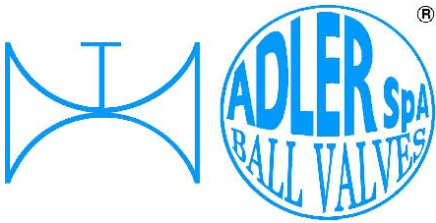

ISO 9001:2008 by L.R.
 PED DIR. 97/23/EC by L.R.
 ATEX DIR. 94/9/EC by B.V.
 FIRE SAFE EXECUTION by L.R.
 ISO 15848 by TÜV
 ANTISTATIC DEVICE by L.R.
 FIRE SAFE TESTED ISO 10497 by L.R.

TYPE
FA8
 PN 10 ÷ 16

VALVOLA A SFERA "CORPO PIATTO" PASSAGGIO TOTALE
 BALL VALVES "WAFER TYPE" FULL BORE

ROBINETS A BOISSEAU SPHERIQUE "WAFER" PASSAGE INTEGRAL
 FLANSCHKUGELHÄHNE IN "KOMPAKTBAUWEISE" VOLLER DURCHGANG

• ESECUZIONI • EXECUTIONS • EXECUTIONS • AUSFÜHRUNGEN



EXECUTION 4 - 12

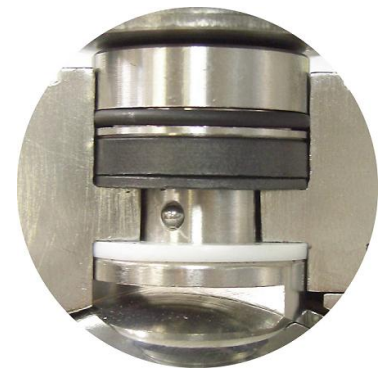
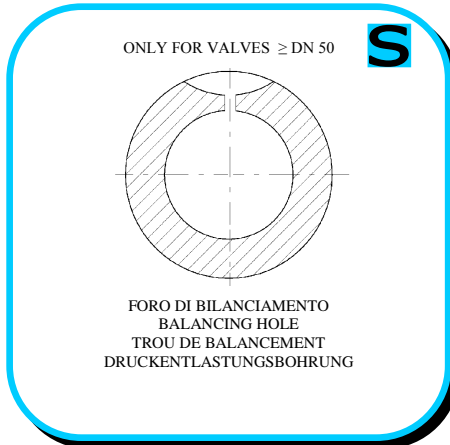

EXECUTION 6 - 16

S STANDARD

O OPTIONAL

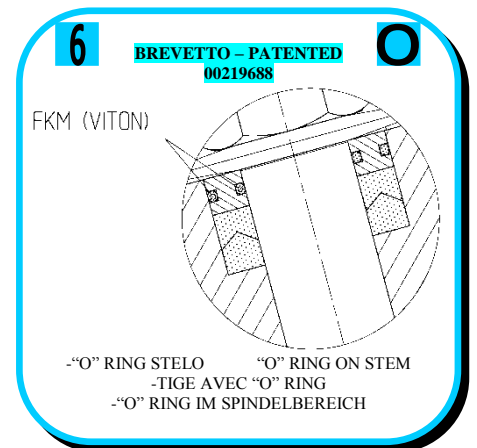
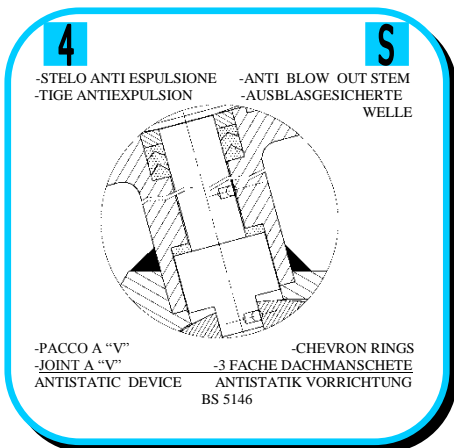
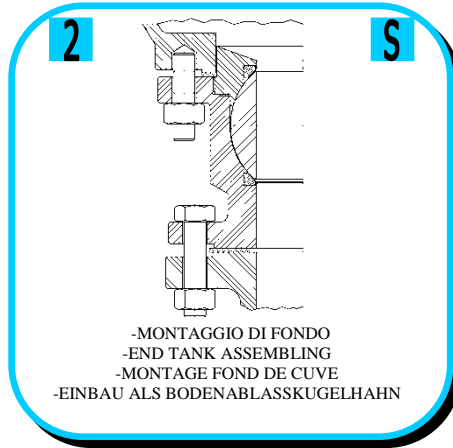
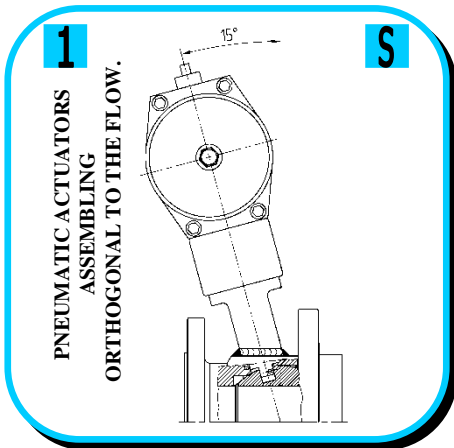

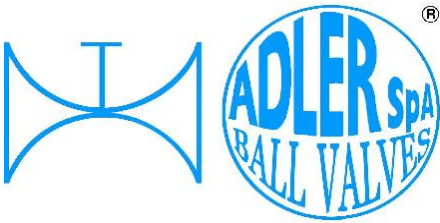

ISO 9001:2008 by L.R.
PED DIR. 97/23/EC by L.R.
ATEX DIR. 94/9/EC by B.V.
FIRE SAFE EXECUTION by L.R.
ISO 15848 by TÜV
ANTISTATIC DEVICE by L.R.
FIRE SAFE TESTED ISO 10497 by L.R.

TYPE
FA8
PN 10 ÷ 16

VALVOLA A SFERA "CORPO PIATTO" PASSAGGIO TOTALE
BALL VALVES "WAFER TYPE" FULL BORE

ROBINETS A BOISEEAU SPHERIQUE "WAFER" PASSAGE INTEGRAL
FLANSCHKUGELHÄHNE IN "KOMPAKTBAUWEISE" VOLLER DURCHGANG

• ESECUZIONI • EXECUTIONS • EXECUTIONS • AUSFÜHRUNGEN

7 **O**

-PROLUNGA STELO -STEM EXTENSION
 -TIGE PROLONGEE -SPINDELVERLÄNGERUNG

8 **O**

-PARTICOLARI INOX
 -STAINLESS STEEL DETAILS
 -ACCESSOIRES EN INOX
 -EDELSTAHLTEILE

9 **S**

-ATTACCO "ISO" -"ISO" CONNECTIONS
 -SYSTEM "ISO" -ANSCHLUSS "ISO"

C.N.C. TOOLING

ADLER

UNA GAMMA COMPLETA
 PRIVILEGIANDO LA QUALITA'

A COMPLETE RANGE PRIVILEGING
 THE QUALITY

12 **O**

FIRE SAFE
ISO 10497 "ISO-FT"
(BS 6755 / API 607)

13 **S**

-DOPPIA TENUTA -DOUBLE SEALS
 -DOUBLE ETANCHEITE -DOPPELTE ABDICHTUNG
 -GHIERA A BATTUTA -METAL BEATING RING
 -EMBOUT AVEC BATTUE MECANIQUE
 -METALLISCHER ANSCHLAG DES
 GEWINDEDRUCKRINGS

14 **O**

VEDERE / SEE ANSI B16.34

FLUSSO
 FLOW

-FORO DI SCARICO NELLA SFERA
 -OVERPRESSURE HOLE INTO BALL
 -TROU DECOMPRESSION DANS LA BOULE
 -ENTLASTUNGSBOHRUNG IN DER KUGEL
VALVOLA MONO DIREZIONALE
MONO-DIRECTIONAL VALVE

15 **O**

P.T.F.E./GRAPHITE
 P.T.F.E.
 100-250

-SERVIZIO CRIOGENICO - CRYOGENIC SERVICE
 -SERVICE CRYOGÉNIQUE
 -TIEFTEMPERATUR SERVICE

16 **O**

-FIRE SAFE + "O" RING STELO
 -FIRE SAFE + "O" RING ON STEM
 -SECURITE FEU + TIGE AVEC "O" RING
 -FEUERSICHERE AUSFÜHRUNG +
 "O" RING IM SPINDELBEREICH

17 **S**

-TENUTA INTEGRALE METALLICA
 -METALLIC POCKET LESS SEATS
 -TENUE INTEGRALE METALLIQUE
 -TOTRAUMARM METALLISCH

18 **O**

-SFERA CIECA PER CAMPIONATURA
 -BLIND BALL FOR SAMPLING
 -PRISE-ECHANTILLON
 -KUGEL FÜR PROBENAHME

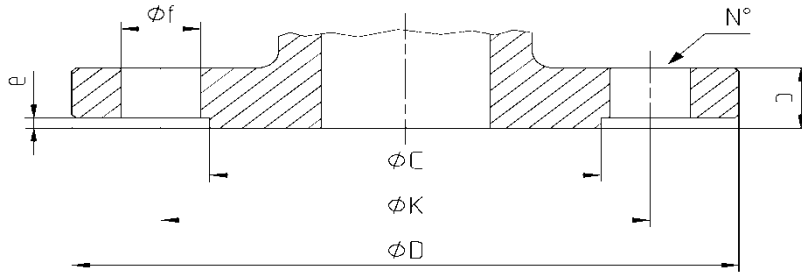

DN	Ref.						50	65	80	100	125				
PN 10	D						165	185	200	220	250				
	C						102	122	138	158	188				
	K						125	145	160	180	210				
	N°						4	4*	8	8	8				
	f						18	18	18	18	18				
	b						18	18	20	20	22				
PN 16	e						3	3	3	3	3				
	D						165	185	200	220	250				
	C						102	122	138	158	188				
	K						125	145	160	180	210				
	N°						4	4*	8	8	8				
	F						18	18	18	18	18				
	b						18	18	20	20	22				
e						3	3	3	3	3					

* N° 8 per UNI 2223/2229

