

# Italgroup<sup>®</sup>

*HYDRAULIC MOTORS*

ITALY



**IAM**

*Single displacement hydraulic motors*

The data specified into the catalogue are for product description purpose only and must not be interpreted as warranted characteristics in legal sense.  
ItalgrouP S.r.l. reserves the right to implement modifications without notice.

All partial or total reproduction and copy without written authorization of ItalgrouP S.r.l. is strictly forbidden.

Press date 03/2013  
IAM rev. 02

# **ITALGROUP - ADVANCED - MOTORS**

## **IAM SERIES**

### **TECHNICAL CATALOGUE**

## **INDEX**

<b>GENERAL INFORMATION</b>	<i>Pag.</i>	<b>2</b>
<b>ORDERING INSTRUCTIONS</b>	"	<b>3</b>
<b>MOTOR TECHNICAL DATA</b>	"	<b>4</b>
<b>HYDRAULIC FLUIDS RECOMMENDATIONS</b>	"	<b>7</b>
<b>INSTRUCTIONS AND ADVICES</b>	"	<b>8</b>
<b>BEARINGS</b>	"	<b>8</b>
<b>SHAFT SEAL FEATURES</b>	"	<b>9</b>
<b>FLUSHING</b>	"	<b>10</b>
<b>DRAIN RECOMMENDATIONS</b>	"	<b>12</b>
<b>FORMULAS</b>	"	<b>13</b>
<b>CONVERSIONS</b>	"	<b>13</b>
<b>IAM H1 SERIES</b>	"	<b>15 - 25</b>
<b>IAM H2 SERIES</b>	"	<b>27 - 39</b>
<b>IAM H3 SERIES</b>	"	<b>41 - 52</b>
<b>IAM H4 SERIES</b>	"	<b>53 - 63</b>
<b>IAM H45 SERIES</b>	"	<b>65 - 70</b>
<b>IAM H5 SERIES</b>	"	<b>71 - 80</b>
<b>IAM H55 SERIES</b>	"	<b>81 - 86</b>
<b>IAM H6 SERIES</b>	"	<b>87 - 94</b>
<b>IAM H7 SERIES</b>	"	<b>95 - 101</b>
<b>IAM H8 SERIES</b>	"	<b>103 - 109</b>
<b>FLOW DISTRIBUTORS</b>	"	<b>111 - 113</b>
<b>ACCESSORIES</b>	"	<b>115 - 135</b>
<b>CONTACT US</b>	"	<b>136</b>
<b>REACH US</b>	"	<b>136</b>



## GENERAL INFORMATION

ITALGROUP produces RADIAL PISTON HYDRAULIC MOTORS since 1985: our yearly production is more than 13.000 units which we sell all over the world through our agents and authorized sellers. Our motor range varies from 20cc to 8500cc displacement and it is completed by two-speed motors and special motors created in cooperation with our clients for different applications such as : underwater, high & low speed and wheel motors and with the possibility to assemble valves, brakes or gear reductions. You can directly contact our Technical Department which will give you all the necessary support to find the right solutions to your problems.

ITALGROUP is a flexible work reality and manages deliveries also within the same day of order; we produce motors exactly interchangeable with our competitors, always ready on stock which our clients particularly appreciate.

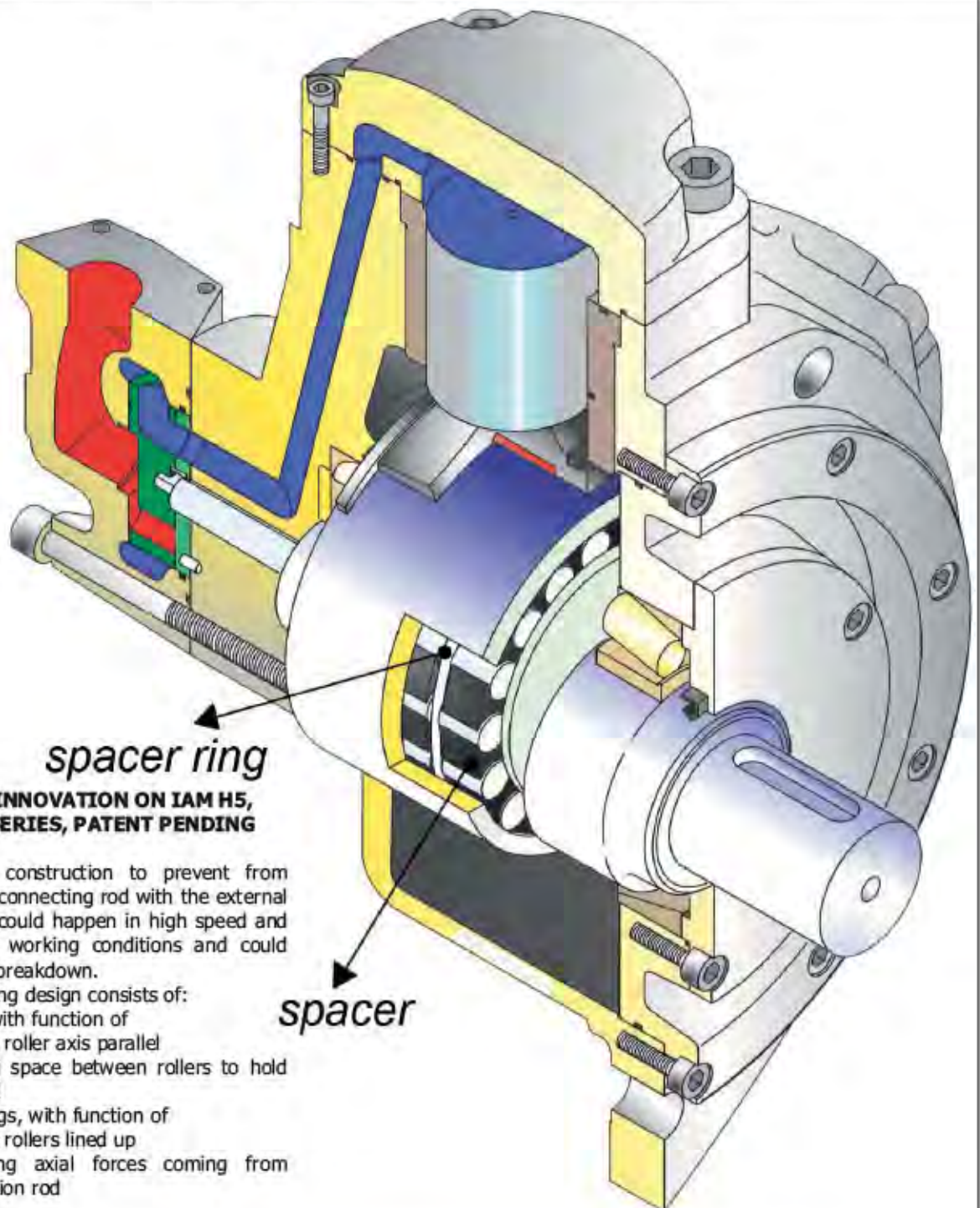

*spacer ring*

### TECHNICAL INNOVATION ON IAM H5, H6 AND H7 SERIES, PATENT PENDING

New bearing construction to prevent from seizure of the connecting rod with the external bushing. This could happen in high speed and high pressure working conditions and could lead to motor breakdown.

The new bearing design consists of:

- spacers, with function of
  - keeping roller axis parallel
  - creating space between rollers to hold more oil
- spacer rings, with function of
  - keeping rollers lined up
  - absorbing axial forces coming from connection rod

*spacer*

## ORDERING INSTRUCTIONS

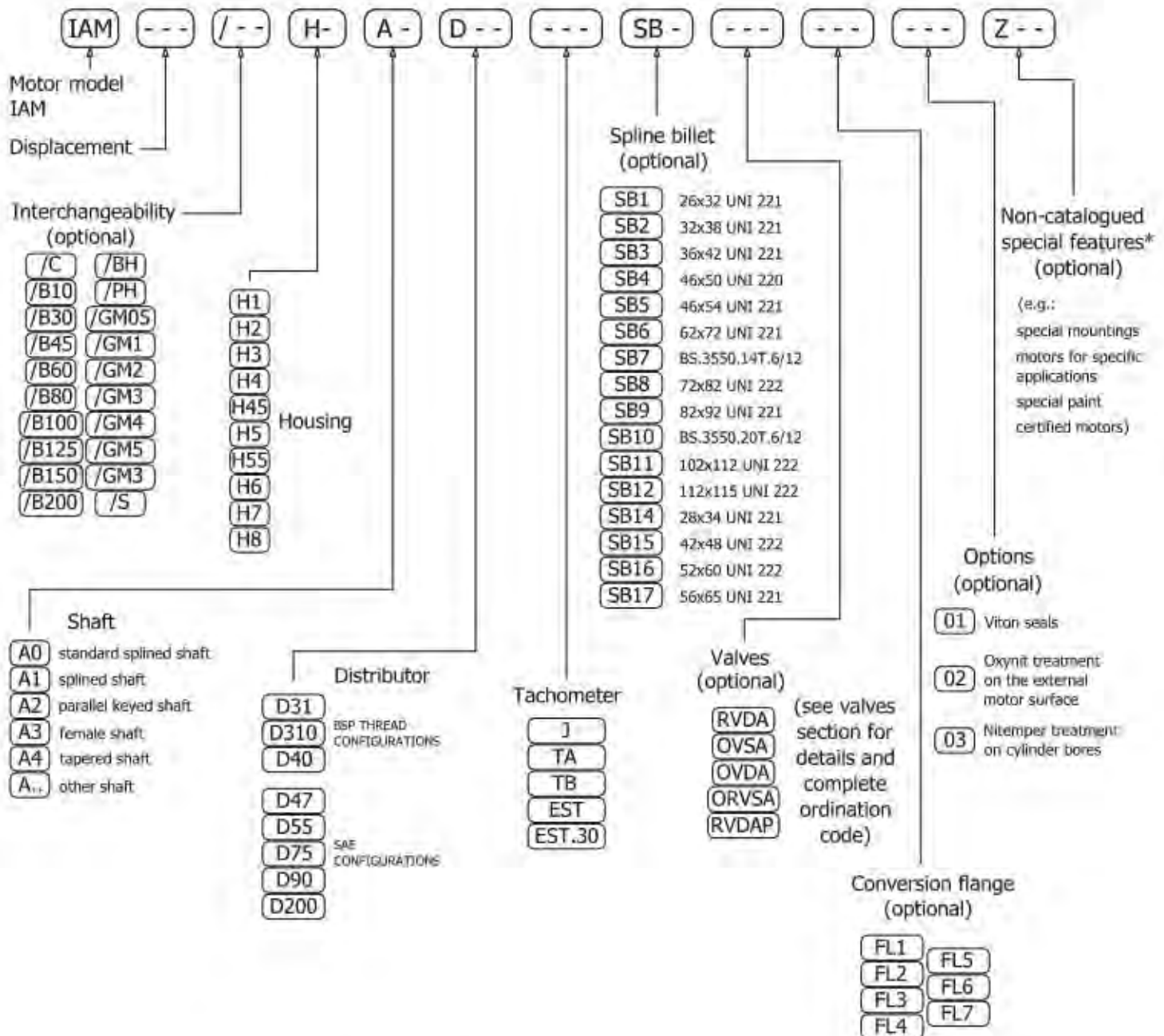

\* For further information please contact our Technical Department

**EXAMPLE:** IAM.100/BH.H1.A0.D40.J.SB14  
IAM.3000.H6.A2.D90.Z43  
IAM.4300/C.H7.A0.D90.TB

For more details on available displacements or shaft options and accessories consult each section of the catalogue concerning IAM family products and accessories.



## MOTOR TECHNICAL DATA

MODEL	N° of pistons	Displacement cc/rev	Specific Torque Nm/bar	Pressure			Speed		Max Case Pressure bar	Max Power		Dry Weight kg	Inertia moment of rotating parts kg cm <sup>2</sup>	
				Max Cont.	Max Int.	Peak	Max Continuous	Peak		hp	kW			
				bar	bar	bar	rpm	rpm		bar	hp			kW
IAM 80	H1	5	80	1.3	250	300	350	950	1050	6	54	40	26	18
IAM 100		5	100	1.6	250	300	350	950	1050	6	54	40	26	18
IAM 150		5	157	2.5	250	300	350	950	1050	6	54	40	26	18
IAM 175		5	176	2.8	250	300	350	800	900	6	54	40	26	18
IAM 195		5	195	3.1	250	300	350	800	900	6	54	40	26	18
IAM 200		5	207	3.3	250	300	350	750	850	6	54	40	26	18
IAM 250		5	257	4.1	250	300	350	750	850	6	54	40	26	18
IAM 300		5	307	4.9	250	300	350	750	850	6	54	40	26	18
IAM 200	H2	5	198	3.2	250	300	350	800	900	6	66	49	42	27
IAM 250		5	253	4.0	250	300	350	750	850	6	66	49	42	27
IAM 300		5	314	5.0	250	300	350	750	850	6	66	49	42	27
IAM 350		5	362	5.8	250	300	350	650	750	6	66	49	42	27
IAM 400		5	424	6.7	250	300	350	600	700	6	66	49	42	27
IAM 500		5	492	7.8	250	300	350	500	600	6	66	49	42	27
IAM 600		5	584	9.3	250	300	350	500	600	6	66	49	42	27
IAM 350	H3	5	349	5.6	250	300	350	630	700	6	91	68	68	214
IAM 400		5	397	6.3	250	300	350	600	680	6	91	68	68	214
IAM 450		5	452	7.2	250	300	350	600	680	6	91	68	68	214
IAM 500		5	491	7.8	250	300	350	600	680	6	91	68	68	214
IAM 600		5	594	9.4	250	300	350	550	630	6	91	68	68	214
IAM 650		5	660	10.5	250	300	350	500	580	6	91	68	68	214
IAM 700		5	707	11.2	250	300	350	450	500	6	91	68	68	214
IAM 800		5	791	12.6	250	300	350	400	450	6	91	68	68	214
IAM 700	H4	5	714	11.4	250	300	350	500	580	6	107	80	92	267
IAM 800		5	792	12.6	250	300	350	450	530	6	107	80	92	267
IAM 850		5	847	13.5	250	300	350	450	530	6	107	80	92	267
IAM 900		5	904	14.4	250	300	350	450	530	6	107	80	92	267
IAM 1000		5	992	15.8	250	300	350	330	400	6	107	80	92	267
IAM 1100		5	1116	17.8	250	300	350	330	400	6	107	80	92	267



# MOTOR TECHNICAL DATA

MODEL	N° of pistons	Displacement cc/rev	Specific Torque Nm/bar	Pressure			Speed		Max Case Pressure bar	Max Power		Dry Weight kg	Inertia moment of rotating parts kg cm <sup>2</sup>	
				Max Cont.	Max Int.	Peak	Max Continuous rpm	Peak rpm		hp	kW			
				bar	bar	bar	rpm	rpm		bar	hp			kW
IAM 1200	H4	5	1192	19.0	250	300	350	300	350	6	107	80	92	267
IAM 1250		5	1247	19.8	250	300	350	250	300	6	107	80	92	267
IAM 1400		5	1332	21.2	250	300	350	230	280	6	107	80	92	267
IAM 1100	H45	5	1183	18.8	250	300	350	350	400	6	161	120	118	380
IAM 1400		5	1376	21.9	250	300	350	300	350	6	161	120	118	380
IAM 1600		5	1648	26.2	250	300	350	275	325	6	161	120	118	380
IAM 1800		5	1815	28.9	250	300	350	250	300	6	161	120	118	380
IAM 1000	H5	5	1094	17.4	250	300	350	350	400	6	161	120	173	697
IAM 1200		5	1231	19.6	250	300	350	300	350	6	161	120	173	697
IAM 1400		5	1376	21.9	250	300	350	300	350	6	161	120	173	697
IAM 1500		5	1528	24.3	250	300	350	300	350	6	161	120	173	697
IAM 1600		5	1648	26.2	250	300	350	300	340	6	161	120	173	697
IAM 1800		5	1815	28.9	250	300	350	250	300	6	161	120	173	697
IAM 2000		5	2035	32.4	250	300	350	230	260	6	161	120	173	697
IAM 2200		5	2220	35.3	250	300	350	220	240	6	161	120	173	697
IAM 2200	H55	5	2126	33.8	250	300	350	240	280	6	228	170	173	837
IAM 2500		5	2525	40.2	250	300	350	240	280	6	228	170	173	837
IAM 2800		5	2807	44.7	250	300	350	240	280	6	228	170	173	837
IAM 3000		5	3028	48.2	250	300	350	230	270	6	228	170	173	837
IAM 2200	H6	5	2206	35.1	250	300	350	220	260	6	228	170	308	1745
IAM 2500		5	2525	40.2	250	300	350	220	260	6	228	170	308	1745
IAM 2800		5	2807	44.7	250	300	350	220	260	6	228	170	308	1745
IAM 3000		5	2983	47.5	250	300	350	210	250	6	228	170	308	1745
IAM 3200		5	3289	52.3	250	300	350	200	240	6	228	170	308	1745
IAM 3500		5	3479	55.4	250	300	350	200	240	6	228	170	308	1745
IAM 3900	H7	7	3907	62.2	250	300	350	160	200	6	241	180	405	4064
IAM 4300		7	4343	69.1	250	300	350	150	190	6	241	180	405	4064
IAM 4600		7	4616	73.5	250	300	350	140	190	6	241	180	405	4064

## MOTOR TECHNICAL DATA

MODEL	N° of pistons	Displacement cc/rev	Specific Torque Nm/bar	Pressure			Speed		Max Case Pressure bar	Max Power		Dry Weight kg	Inertia moment of rotating parts Kg cm <sup>2</sup>	
				Max Cont.	Max Int.	Peak	Max Continuous	Peak		hp	kW			
				bar	bar	bar	rpm	rpm						
IAM 5000	H7	7	5088	81.0	250	300	350	140	180	6	241	180	405	4064
IAM 5400		7	5384	85.7	250	300	350	130	170	6	241	180	405	4064
IAM 6000	H8	10	5966	95.0	250	290	320	120	140	6	255	190	590	5380
IAM 6500		10	6581	104.7	250	290	320	120	140	6	255	190	590	5380
IAM 6800		10	6962	110.8	250	290	320	120	140	6	255	190	590	5380
IAM 7600		10	7620	121.3	190	230	280	90	100	6	241	180	590	5380
IAM 8000		10	8062	128.3	180	220	270	80	90	6	241	180	590	5380



# HYDRAULIC FLUIDS RECOMMENDATIONS

## HYDRAULIC FLUIDS

We recommend the use of hydraulic oils with anti-wear additives (ISO HM or HV) and minimum viscosity index of 95. Once normal working temperature is reached, oil viscosity must be at least 12 cSt, preferably in the range from 20 to 60 cSt.

Hydraulic oils meeting Denison MF-O, Vickers M-2952-S I - 286-S performance requirements and DIN 51524 specifications, are preferred.

Mineral hydraulic oils are divided into four main types, designated by the International Standards Organisation (ISO) as HH, HL, HM and HV. We advise to use only products with HM or HV specifications.

### HM type

These are the most widely employed hydraulic oils. They include small quantities of anti-wear additives to provide significant improvement in wear reduction. "Superior" quality HM type oils can be used for all equipment, with the added assurance that they will be suitable for the highest temperature.

### HV type

HV hydraulic oils show minimal change in viscosity with temperature variations.

## OIL VISCOSITY RECOMMENDATION

Room temperature HM type ISO-VG

- -20°C / 0°C BP ENERGOL HLP - HM 22
- -15°C / +5°C BP ENERGOL HLP - HM 32
- -8°C / +15°C BP BNERGOL HLP - HM 46
- 0°C / +22°C BP ENERGOL HLP - HM 68
- +8°C / +30°C BP ENERGOL HLP - HM100
- -20°C / +5°C BP BARTRAN HV 32
- -15°C / +22°C BP BARTRAN HV 46
- 0°C / +30°C BP BARTRAN HV 68

Our motors have been designed to work also with:

- oils type ATF (Automatic Transmission Fluid)
- oils with viscosity SAE 10W - 20 - 30
- multigrade motor oils SAE 10 W/40 or 15 W/40
- universal oils

During cold start-up, avoid high-speed operation until the system is warmed up to provide adequate lubrication.

Continuous working temperature must not exceed 70°C.

When the working conditions cause the oil viscosity decrease under the minimum recommended value, to guarantee a sufficient motor lubrication it is necessary an adequate motor flushing (see flushing page for more details).

## FIRE RESISTANT OIL LIMITATIONS

	Max cont. pressure	Max int. pressure	Max speed
HFA, 5-95% oil-water	103	138	50%
HFB, 60-40% oil-water	138	172	100%
HFC, water-glycol	103	138	50%
HFD, ester phosphate	250	293	100%

## FILTRATION

Hydraulic systems oil must always be filtered.

The choice of filtration grade derives from needs of service life and money spent. In order to obtain stated service life it is important to follow our recommendations concerning filtration grade.

When choosing the filter it is important to consider the amount of dirt particles that filter can absorb and still operate satisfactorily. For that reason we recommend filters showing when you need to substitute filtering cartridge.

- 25 µm filtration required in most applications
- 10 µm filtration in closed circuit applications

## OXIDATION

Hydraulic oil oxidizes with time of use and temperature. Oxidation causes changes in colour and smell, acidity increase or sludge formation in the tank. Oxidation rate increases rapidly at surface temperatures above 60°C, in these situations oil should be checked more often.

The oxidation process increases the acidity of the fluid; the acidity is stated in terms of the "neutralization number". Oxidation is usually slow at the beginning and then it increases rapidly.

A sharp increase (by a factor of 2 to 3) in neutralization number between inspections shows that oil has oxidized too much and should be replaced immediately.

## WATER CONTENT

Oil contamination by water can be detected by sampling from the bottom of the tank. Most hydraulic oils repel the water, which then collects at the bottom of the tank. This water must be drained off at regular intervals. Certain types of transmission oils and engine oils emulsify the water; this can be detected by coatings on filter cartridges or a change in the colour of the oil. In such cases, obtain your oil supplier advice.

## DEGREE OF CONTAMINATION

Heavy contamination of the oil causes wear rising in hydraulic system components. Contamination causes must be immediately investigated and remedied.

## ANALYSIS

It is recommended oil being analyzed every 6 months. The analysis should cover viscosity, oxidation, water content, additives and contamination. Most oil suppliers are equipped to analyze oil state and to recommend appropriate action. Oil must be immediately replaced if the analysis shows that it is exhausted.



## INSTRUCTIONS AND ADVICES

### INSTALLATION

Hoses and piping must be clean and free from contamination. No other special requirements are necessary.

- Motor can be mounted in any position
- In run-away conditions you must use counterbalance valves
- Consult factory for intermittent applications

Splined adaptors (sleeves) are available upon request.

### INSTALLATION CIRCUIT

The choice of open or closed loop circuit will be determined by the application.

Open loop circuits are cheaper and simpler to install.

Closed loop circuit is a superior circuit and usually takes up less space. It also offers better control features.

### START UP

Motor case and pistons must be completely filled with oil before starting.

Do not load motor to maximum working pressure. Increase load gradually at start-up.

### CASE DRAIN – CASE PRESSURE

Connect the case drain directly to tank.

The case drain port on the motor must be located on the highest point of the installation to ensure that the motor will always be full of oil. The case drain pressure must not exceed 6 bar continuous pressure.

### IMPORTANT

When the motor is installed vertically with shaft pointing upwards, consult our Technical Department. If the motor is connected to high inertial loads, the hydraulic system must be designed to prevent peaks of pressure and cavitation.

### TEMPERATURE

Maximum oil temperature must not exceed 70°C. Heat exchangers must be used with higher temperatures.

### VISCOSITY

The motor works satisfactory in a range of 3°E to 10°E oil viscosity. Best performance is obtained at the highest viscosity.

### BACK PRESSURE

Don't exceed 70 bar back pressure.

### HIGH PEAKS APPLICATIONS

In case of high pressure peaks applications, a Nitemper treatment on cylinders is suggested to increase wear and tear resistance.

### CONTINUOUS HIGH SPEED DUTY

In case of continuous high speed duty, it is suggested to mount a central reinforced bearing on motor shaft, please contact our Technical Department.

### MINIMUM SPEED

Standard minimum speed is about 0.5 to 3 rpm (depending on motor displacement). If you need less speed, it is possible to modify some parts of the distributor.

### FLUSHING

In the need of Flushing, a 2nd drain hole is available upon request. When flushing is not available, it is possible to create an inner motor drain to help cooling.

### COOLING FLOW

If the motor operates in the Intermittent Power zone, it may require a cooling flow of 20 l/min (5 gpm) to keep a drain flow viscosity of 40 cSt minimum.

**FOR MORE DETAILS ON THE ABOVE MENTIONED ARGUMENTS AND FOR ANY FURTHER INFORMATION PLEASE CONTACT OUR TECHNICAL DEPARTMENT.**

## BEARINGS

Bearings lifetime depends on the type of bearing, on motor speed and on working loads.

Lifetime is measured by  $L_{10}$  which is called "theoretic lifetime". It represents the number of cycles that 90% of identical bearings can effort at the same load without showing wear and tear. It is calculated by the following equation:

$$L_{10} = \left( \frac{C}{P} \right)^p$$

where: C = theoretical dynamic coefficient (depending on the bearing size)

P = radial load

p = exponent (p=3 for ball bearings, p=10/3 for roller bearings)

When you work at constant speed, you can calculate the lifetime in hours with the following equation:

$$L_{10h} = \frac{10^6 \cdot L_{10}}{60 \cdot \text{rpm}} = \frac{10^6}{60 \cdot \text{rpm}} \left( \frac{C}{P} \right)^p \text{ [h]}$$

When you don't have only radial or axial loads, you have to calculate an equivalent load:

$$P = X \cdot F_R + Y \cdot F_A$$

Where

$F_R$  = radial load,

X = radial coefficient,

$F_A$  = axial load,

Y = axial coefficient

While  $F_R$  and  $F_A$  come from working conditions (i.e. torque),

X and Y depend on the type of bearing and on the ratio  $\frac{F_A}{F_R}$ .

To help you in the expected lifetime calculation, Italgrou provides you with an EXCEL calculation sheet. With this instrument you can easily calculate lifetime: you only need to choose the motor model, put speed, pressure and loads.

**For further information or to have the calculation sheet, please contact our Technical Department.**



# SHAFT SEAL FEATURES

Type: BABSL  
 Form: AS DIN 3760  
 Material: SIMRIT® 72 NBR 902  
 SIMRIT® 75 FKM 595

### 1. Features

SIMMERRING® radial shaft seal with rubber covered O.D., short, flexibility suspended, spring loaded sealing lip and additional dust lip: see Part B/ SIMMERRING®, sections 1.1 and 2.

### 2. Material

Sealing lip and O.D.:

- Acrylonitrile-butadiene rubber with 72 Shore

A hardness (designation: SIMRIT® 72 NBR 902)

- Fluoro rubber with 75 Shore A hardness (designation: SIMRIT®75 FKM 595)

Metal insert:

- Plain steel DIN 1624

Spring:

- Spring steel DIN 17223

### 3. Application

For sealing pressurised media without additional backup ring, e. g. for rotational pressure sealing in hydraulic pumps, hydraulic motors, hydrodynamic clutches. Rubber covered O.D. assures sealing in the housing bore even in case of considerable surface roughness, thermal expansion or split housing.

Particularly suitable for sealing low viscosity and gaseous media.

Where high thermal stability and chemical resistance are required, SIMRIT® 75 FKM 595 material should be used. Additional dust lip to avoid the entry of light and medium dust and dirt.

### 4. Operating conditions

See Part B/ SIMMERRING®, sections 2. 4.

Media: mineral oils, synthetic oils

Temperature: -40°C to +100°C (SIMRIT® 72 NBR 902)

-40°C to +160°C (SIMRIT® 75 FKM 595)

Surface speed: up to 5 m/s

Working pressure: see diagram 1

Maximum permitted values, depending on other operating conditions.

### 5. Housing and Machining Criteria

See Part B/ SIMMERRING®, sections 2.

Shaft:	Tolerance:	ISO h11
	Concentricity:	IT 8
	Roughness:	Ra=0.2-0.8 µm Rz=1-4 µm Rmax=6 µm
	Hardness:	45-60 HRc
	Roughness:	non oriented; preferably by plunge grinding
Housing:	Tolerance:	ISO H8
	Roughness:	Rmax<25 µm

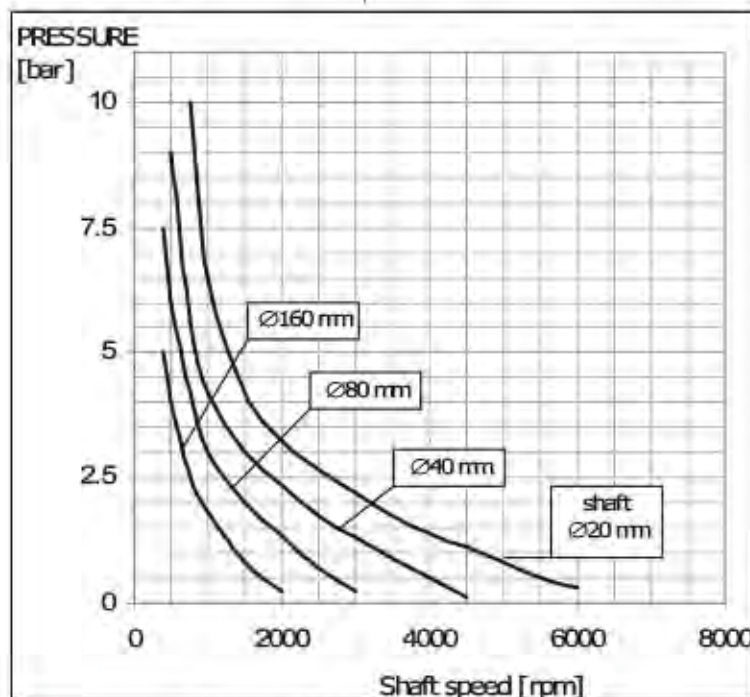

Diagram 1: Pressure Loading Limits

## FLUSHING

### FLUSHING FLOW

Cooling flow is necessary to assure the minimum oil viscosity. The following table shows the flushing flow approximate values that are suggested for IAM motors. In all the cases, the flushing flow must be adequate to assure the minimum oil viscosity (see page 7): therefore the flushing flow will depend by the motor displacement, working conditions and oil type, and must be set making some oil drain temperature monitoring.

Motor	Flushing flow (l/min)
IAM H1 80, 100	5
IAM H1 150, 175, 195, 200, 250, 300	6
IAM H2 200, 250, 300	8
IAM H2 350, 400, 500	
IAM H3 350, 400, 450, 500	
IAM H2 600	
IAM H3 600, 650, 700, 800	
IAM H4 700, 800, 850, 900, 1000, 1100	10
IAM H4 1200, 1250, 1400	
IAM H5 1000, 1200, 1400, 1600, 1800, 2000	
IAM H5 2200	
IAM H6 2500, 2800, 3000, 3200, 3500	15
IAM H7 3900, 4300, 4600, 5000, 5400	
IAM H8 6500, 6800, 7600, 8000, 8500	20

### FLUSHING IN PERFORMANCE DIAGRAMS

Each performance diagram shows working conditions where flushing is suggested (areas numbered from 4 to 6 in each performance diagram).

**Area 1:** Continuous operation

**Area 2:** Intermittent operation for period 3-5 minute every 10-15 minute

**Area 3:** Intermittent operation for very short period (3-5 seconds every 10-15 minutes)

**Area 4:** Continuous operation with flushing

**Area 5:** Intermittent operation for period 3-5 minute every 10-15 minute with flushing

**Area 6:** Intermittent operation for very short period (3-5 seconds every 10-15 minutes) with flushing

### HIGH VOLUMETRIC EFFICIENCY MOTORS

On radial piston hydraulic motors with high volumetric efficiency, and therefore Italgrou IAM series, there can be a phenomenon of oil-overheating in the body motor.

Oil drawing from the piston and from the distributor goes into body motor. When this oil quantity is very scanty, it means there's a good volumetric efficiency. In some cases this is positive, like for winch on crane truck or trawl winch, because high volumetric efficiency avoids motor rotation even under external stress.

This scanty quantity of oil is not a problem because the motor works at high pressure only for a short period of time.

In other cases, this high efficiency can cause problems on the motor because oil exchange is missing.

In fixed applications, for example, where the motor is running constantly for 8 or more hours a day (like injection machines for plastic materials, press, bending machines, etc.) high volumetric efficiency can create temperature increasing in motor body.

In this case temperature increasing is to be avoided with the use of flushing.

Flushing consists in carrying fresh oil (taken from hydraulic circuit) in the body motor.

Oil is usually taken from return line to avoid any loss of efficiency.

In this way, all internal parts of the motor are protected with this lubrication and cooled with fresh oil, so that total efficiency is optimised.

### FLUSHING CIRCUIT (ONE DIRECTION WORKING)

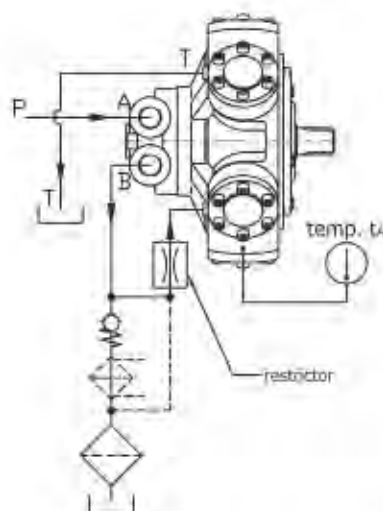

### FLUSHING CIRCUIT (BIDIRECTIONAL WORKING)

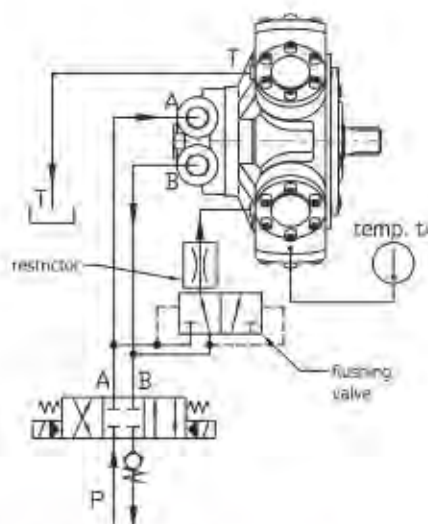

For further information please contact Italgrou technical department



## Motor flushing circuit example for unidirectional working

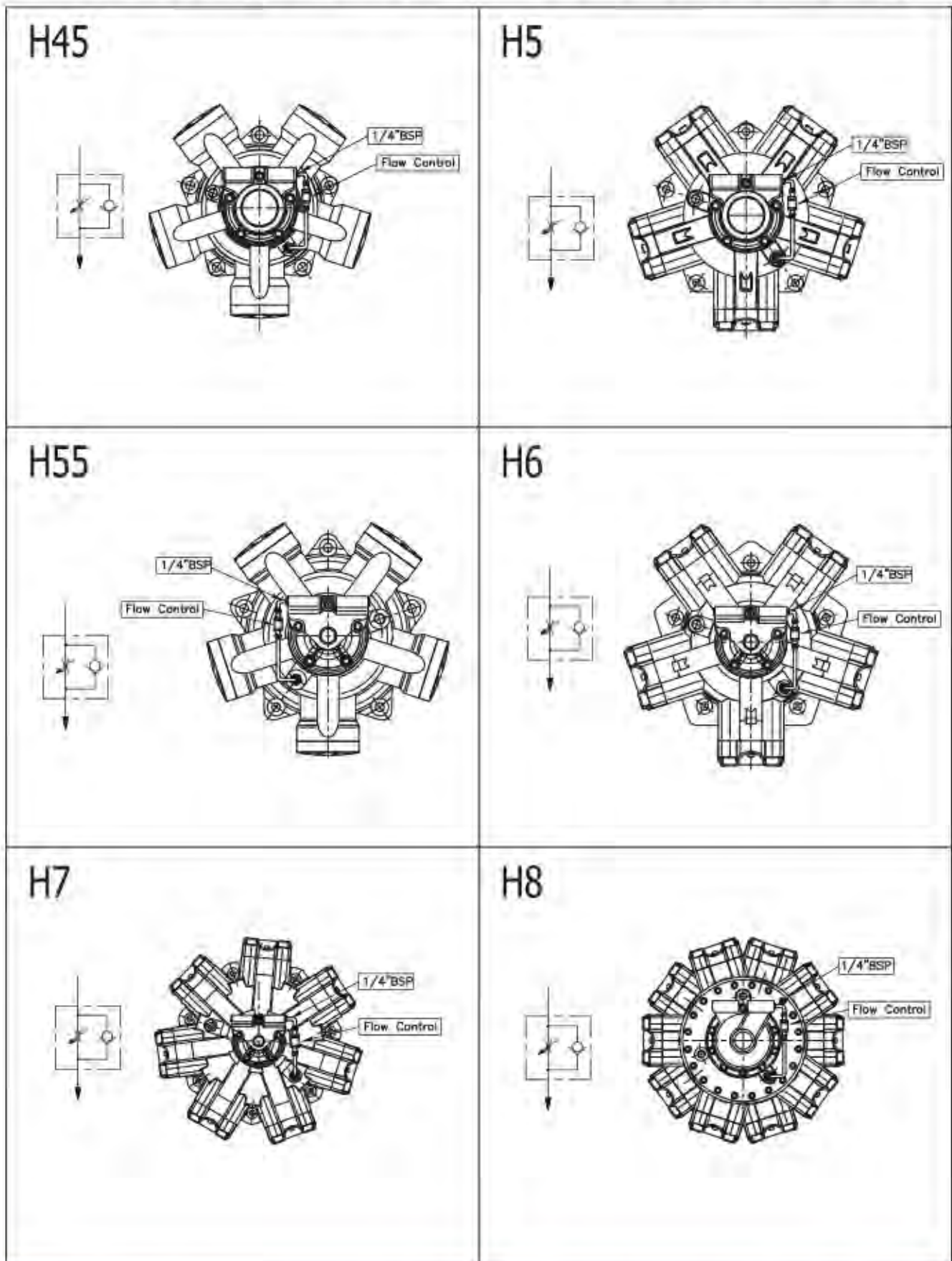

## DRAIN RECOMMENDATIONS

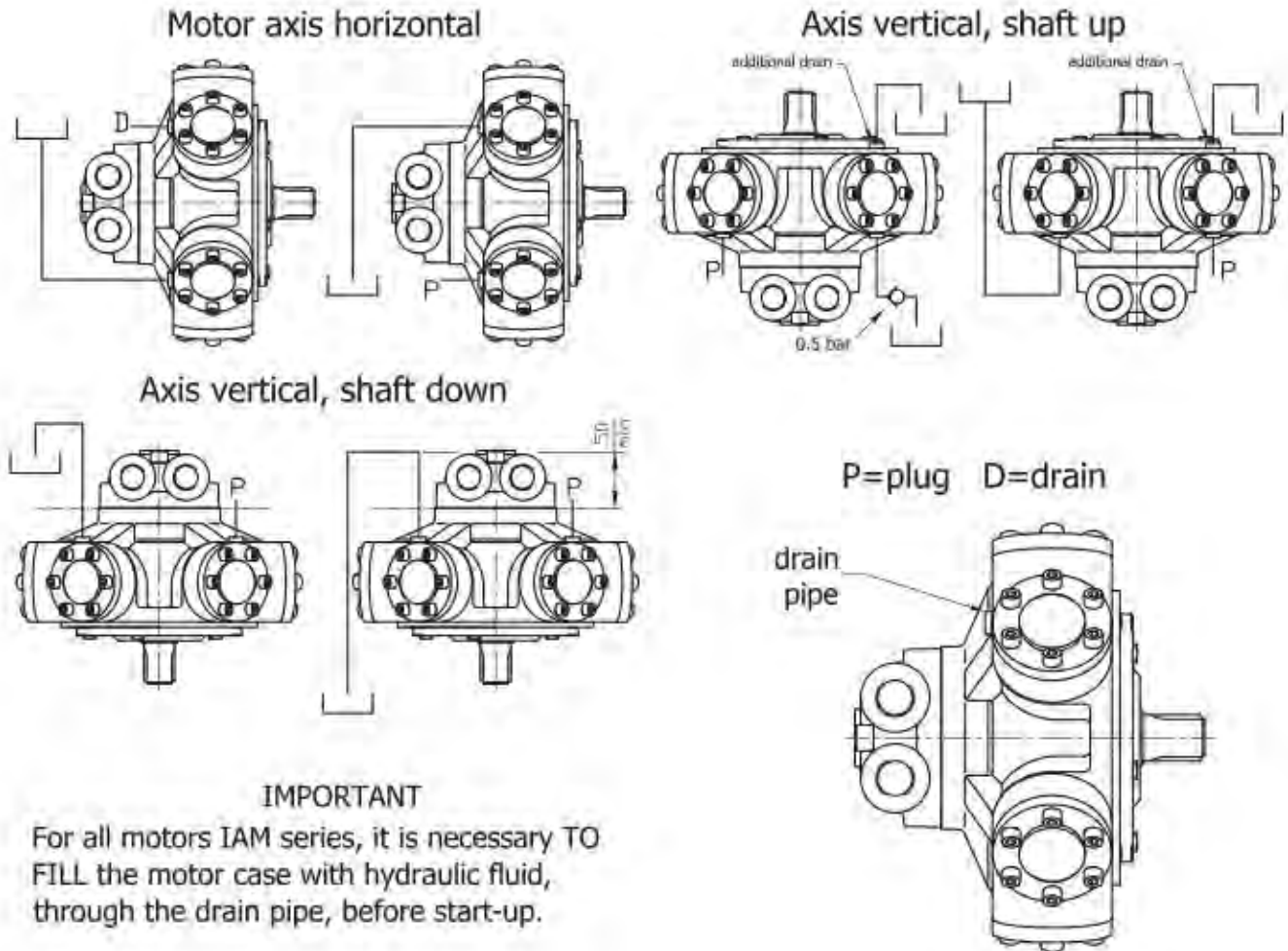

## DISTRIBUTORS PRESSURE – FLOW

		D31/D310 (IAM H1, H2, H3, H4)	D40/D47 (IAM H1, H2, H3, H4, H45)	D55 (IAM H5, H45)	D75 (IAM H5, H45, H55)	D90 (IAM H55, H6, IAMH7)	D200 (IAM H8)
Pressure bar	Continuous	250	250	250	250	250	250
	Max	500	500	400	500	500	500
Flow L/min	Continuous	200	200	300	500	600	1000
	Max	400	400	600	1000	1200	2000



## FORMULAS

• TORQUE (1)	$\text{Torque} = (\text{specific torque}) \cdot (\text{pressure})$
• TORQUE (2)	$\text{Torque [Nm]} = \frac{\text{displacement [cc/rev]} \cdot \text{pressure [bar]}}{62.8}$
• POWER (1)	$\text{Power [kW]} = \frac{\text{Torque [Nm]} \cdot \text{speed [rpm]}}{9549}$
• POWER (2)	$\text{Power [CV]} = \frac{\text{Torque [Nm]} \cdot \text{speed [rpm]}}{7023}$
• SPEED	$\text{speed [rpm]} = \frac{\text{flow rate [l/min]} \cdot 1000}{\text{displacement [cc/rev]}}$
• REQUIRED MOTOR DISPLACEMENT	$\text{displacement [cc/rev]} = \frac{\text{max required torque [Nm]} \cdot 62.8}{\text{max pressure [bar]}}$
• REQUIRED PUMP FLOW RATE	$\text{flow [l/min]} = \frac{\text{displacement [cc/rev]} \cdot \text{max speed [rpm]}}{1000}$

## CONVERSIONS

<b>LENGTH</b>	1 m = 39.3701 in	1 lbf = 0.4536 kgf
	= 3.2808 ft	= 4.448 N
	= 1.0936 yd	
	= 1000 mm	<b>PRESSURE</b>
1 in = 0.0833 ft		1 bar = 14.223 psi
= 25.4 mm		= 0.99 atm
1 ft = 0.3048 m		= 1.02 ata
= 0.3333 yd		= 100000 Pa
= 12 in		= 100 kPa
1 yd = 0.9144 m		= 0.1 MPa
= 3 ft		1 psi = 0.0703 bar
= 36 in		
1 km = 1000 m		<b>FLOW</b>
= 1093.6 yd		1 l/min = 0.264 gpm
= 0.6214 mile		= 1000 cc/min
1 mile = 1.609 km		1 gpm = 3.785 l/min
= 1760 yd		= 3785 cc/min
		1 m <sup>3</sup> /s = 60000 l/min
		= 15852 gpm
<b>MASS</b>	1 kg = 2.2046 lb	<b>VOLUME</b>
1 lb = 0.4536 kg		1 m <sup>3</sup> = 1000 l
		1 l = 61,023 in <sup>3</sup>
<b>SPEED</b>	1 m/s = 3.6 km/h	= 0,264 galUS
	= 2.237 mph	1 in <sup>3</sup> = 0,01639 l
	= 3.2808 ft/s	= 0,004326 galUS
1 km/h = 0.2778 m/s		1 galUS = 3,7879 l
= 0.6214 mph		= 231,15 in <sup>3</sup>
= 0.9113 ft/s		
1 mph = 1.609 km/h		<b>POWER</b>
= 0.447 m/s		1 kW = 1.341 HP
= 1.467 ft/s		= 1.3596 CV
1 ft/s = 0.3048 m/s		1 HP = 0.7457 Kw
= 1.0973 km/h		= 1.0139 CV
= 0.6818 mph		
<b>FORCE</b>	1 N = 0.102 kgf	<b>TORQUE</b>
= 0.2248 lbf		1 Nm = 0.102 kgm
1 kgf = 2.205 lbf		= 0.7376 lbf ft
= 9.806 N		1 kgm = 9.806 Nm
		= 7.2325 lbf ft
		1 lbf ft = 0.1383 kgm
		= 1.3558 Nm





---

# ***ITALGROUP-ADVANCED-MOTORS***

## ***IAM SERIES***

---

### ***H1 MODEL***

---

***IAM 80-100-150-175  
195-200-250-300 H1***

***IAM 100-150-175-195  
200-250/BH H1***

***IAM 100-150-175-195  
200-250/GM05 H1***

***IAM 100-150-175-195  
200-250/GM1 H1***

***IAM 200-250-300/PH H1***

---

## ***INDEX***

TECHNICAL DATA - - - - -	Pag. 16
IAM H1 80-100-150-175-195 - - - - -	" 17
IAM H1 200-250-300 - - - - -	" 18
IAM H1 100-150-175-195-200-250/GM05 - - - - -	" 19
IAM H1 100-150-175-195-200-250/BH - - - - -	" 20
IAM H1 100-150-175-195-200-250/GM1 - - - - -	" 21
IAM H1 200-250-300/PH - - - - -	" 22
ORDERING INSTRUCTIONS - - - - -	" 23
GRAPHIC PERFORMANCES H1 80-100-150-175 - - - - -	" 24
GRAPHIC PERFORMANCES H1 195-200-250-300 - - - - -	" 25

---

## TECHNICAL DATA

## H1

MODEL		IAM 80 H1	IAM 100 H1	IAM 150 H1	IAM 175 H1	IAM 195 H1	IAM 200 H1	IAM 250 H1	IAM 300 H1
Displacement	cc/rev	80	100	157	176	195	207	257	307
Specific Torque	Nm/bar	1.3	1.6	2.5	2.8	3.1	3.3	4.1	4.9
Max cont. Pressure	bar	250	250	250	250	250	250	250	250
Max int. Pressure	bar	300	300	300	300	300	300	300	300
Peak pressure	bar	350	350	350	350	350	350	350	350
Max continuous speed	rpm	950	950	950	800	800	750	750	750
Peak speed	rpm	1050	1050	1050	900	900	850	850	850
Max continuous power	HP	27	37	37	37	37	37	37	37
	kW	20	27	27	27	27	27	27	27
Max power	HP	54	54	54	54	54	54	54	54
	kW	40	40	40	40	40	40	40	40

- N° of pistons: 5
- Max case pressure: 6 bar
- Max back pressure: 70 bar
- Dry weight: 26 kg
- Temperature range: -30°C ÷ +70°C
- Minimum speed: 2÷3 rpm
- Flushing flow<sup>(\*)</sup>:
 

IAM H1 80 – 100 – 150	5 l/min
IAM H1 175 – 195 – 200 – 250 – 300	6 l/min

(\*)for further details regarding flushing go to page 10 of this catalogue.



## SIZE

### IAM 80-100-150-175-195 H1

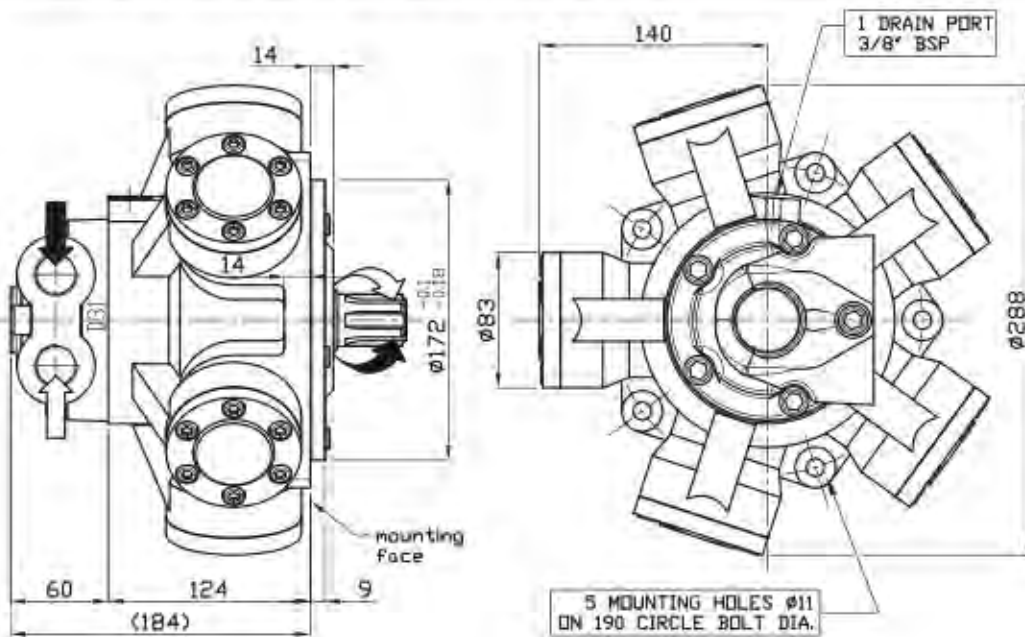

## SHAFT

### IAM 80-100-150-175-195 H1

A0: Standard splined shaft

A1: Splined shaft on request

A2: Parallel shaft on request

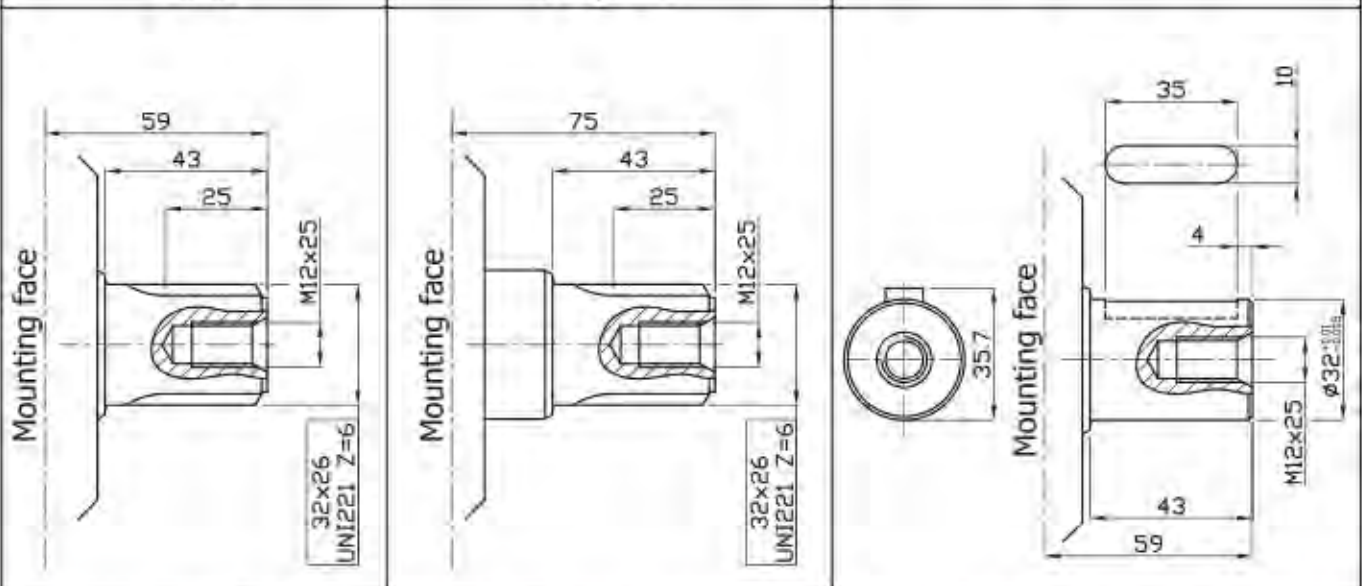

FEMALE SHAFT AVAILABLE UPON REQUEST N35x2x30x16x9H DIN 5480 (100 and 150 cc/Rev only)

## SIZE

### IAM 200-250-300 H1

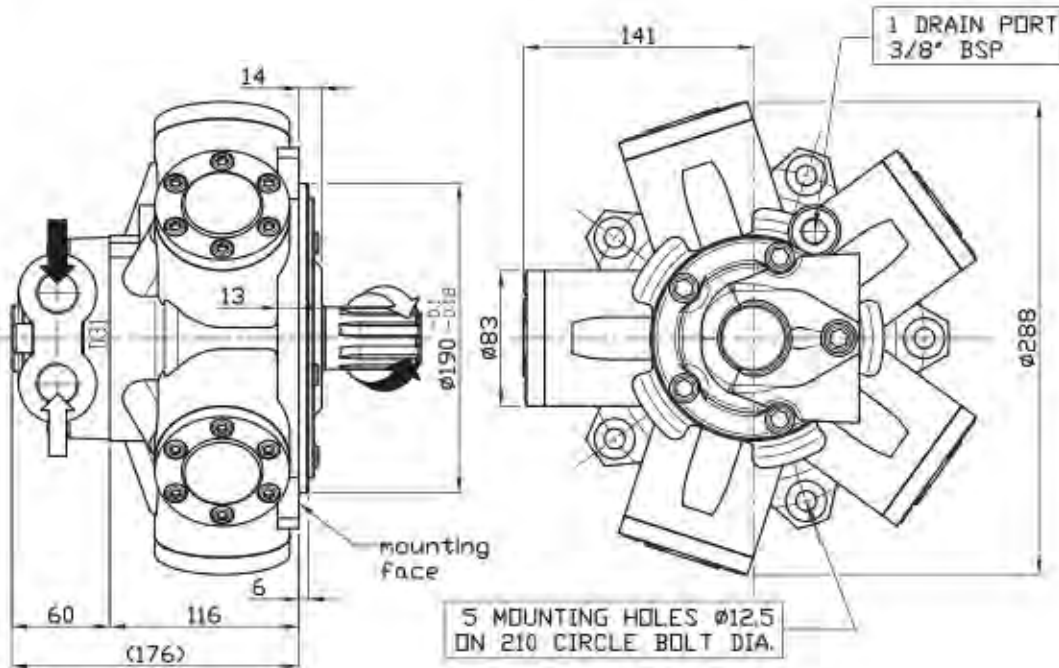

## SHAFT

### IAM 200-250-300 H1

A0: Standard splined shaft

A2: Parallel shaft on request

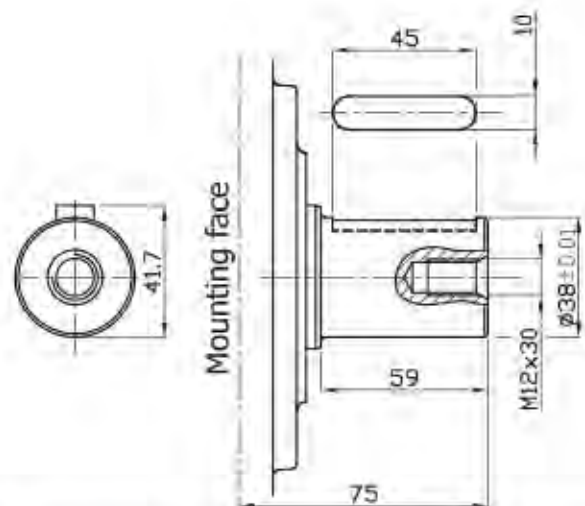
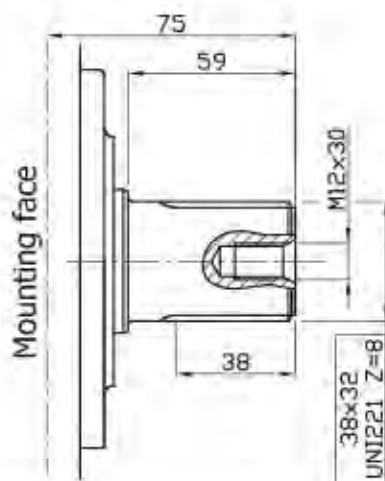

FEMALE SHAFT AVAILABLE UPON REQUEST N35x2x30x16x9H DIN 5480 (300 cc/Rev only)



INTERCHANGEABLE WITH GM05

## SIZE

IAM 100/GM05 150/GM05 175/GM05 195/GM05 250/GM05 H1

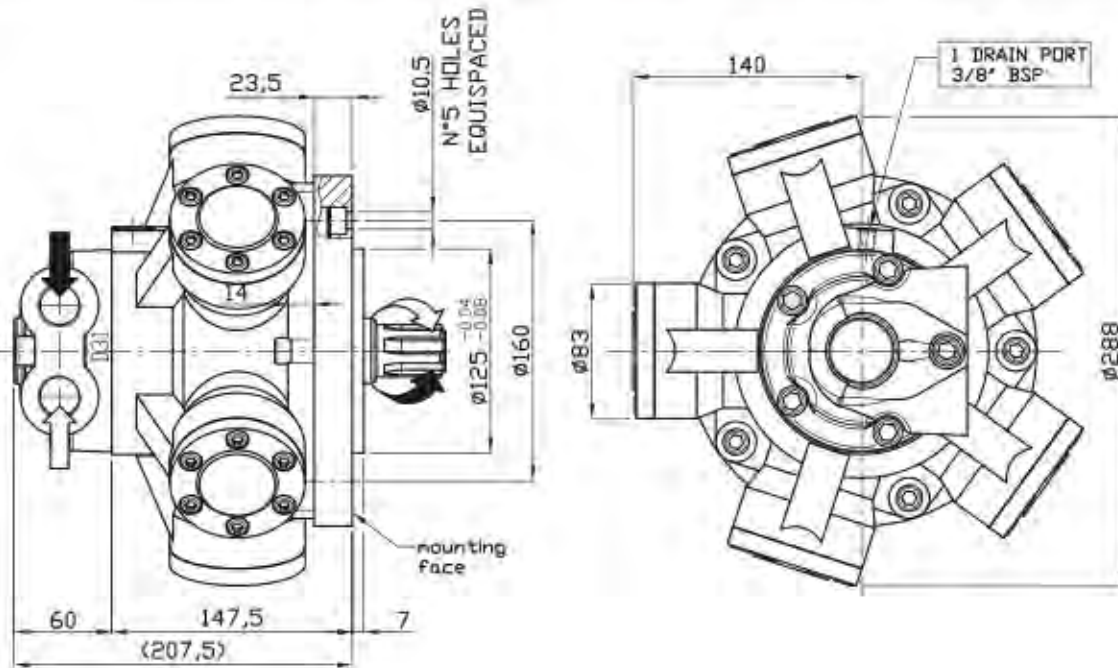

## SHAFT

IAM 100/GM05 150/GM05 175/GM05 195/GM05 250/GM05 H1

A0: Standard splined shaft

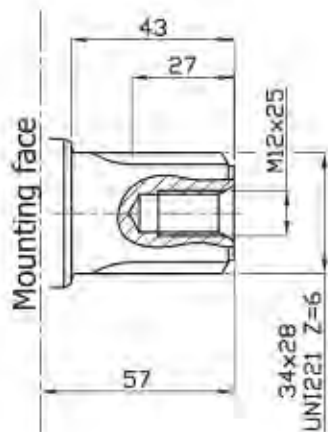

## SIZE

### IAM 100/BH-150/BH-175/BH-195/BH-250/BH H1

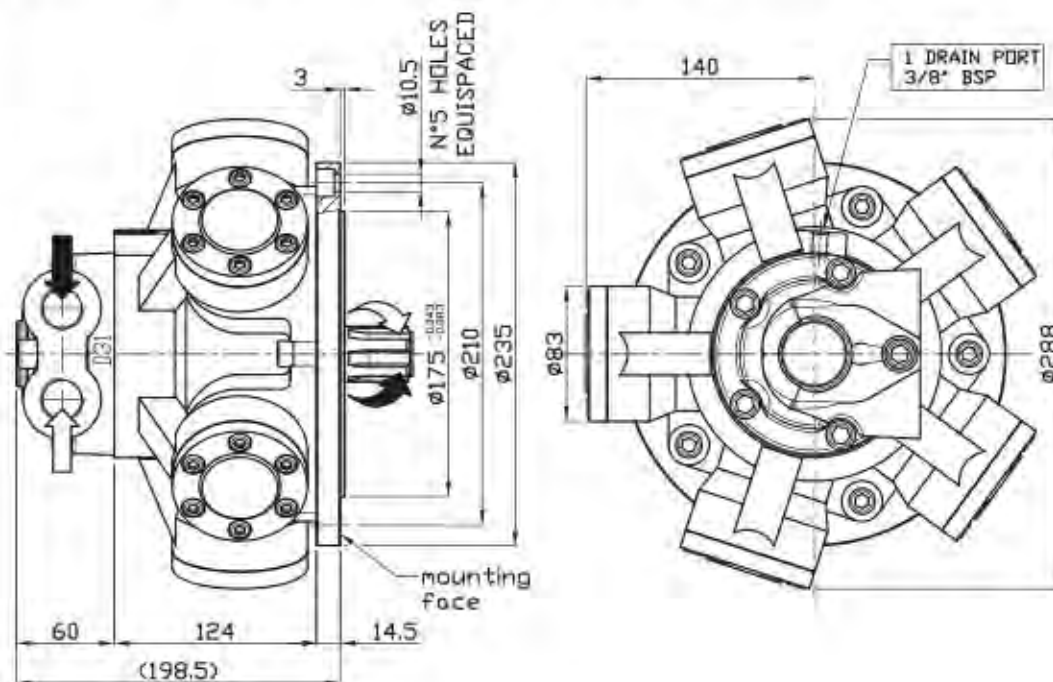

## SHAFT

### IAM 100/BH-150/BH-175/BH-195/BH-250/BH H1

A0: Standard splined shaft

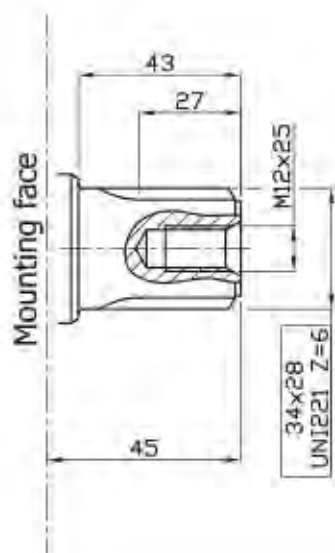



## SIZE

IAM 100/GM1-150/GM1-175/GM1-195/GM1-250/GM1 H1

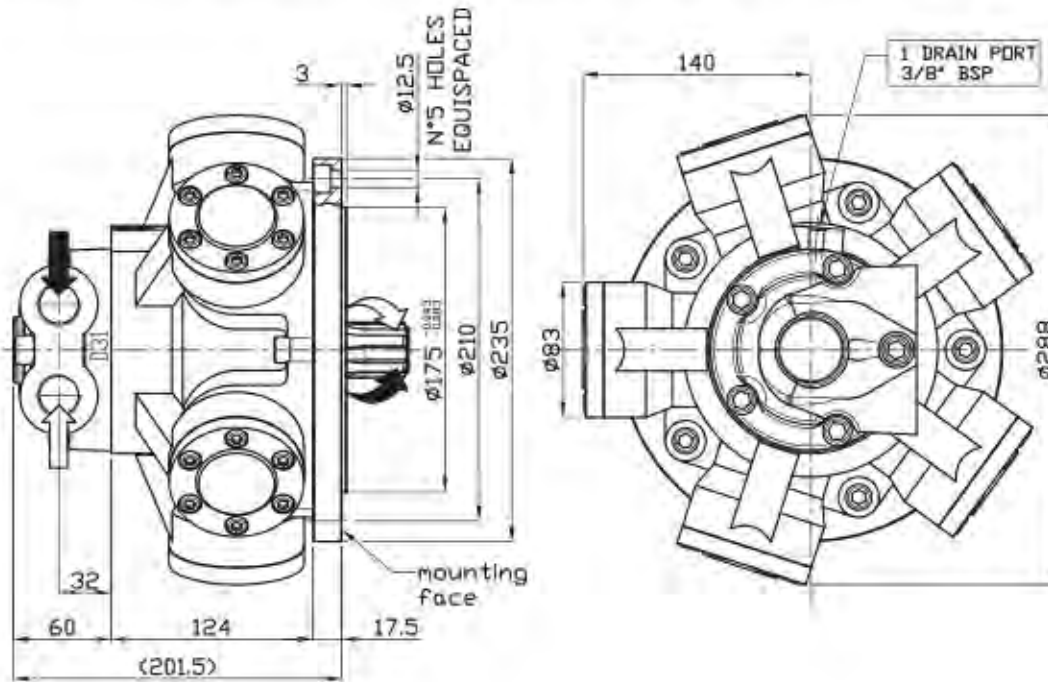

## SHAFT

IAM 100/GM1-150/GM1-175/GM1-195/GM1-250/GM1 H1

A0: Standard splined shaft

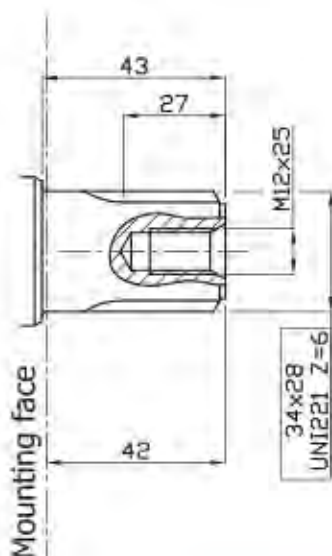

## SIZE

### IAM 200/PH-250/PH-300/PH H1

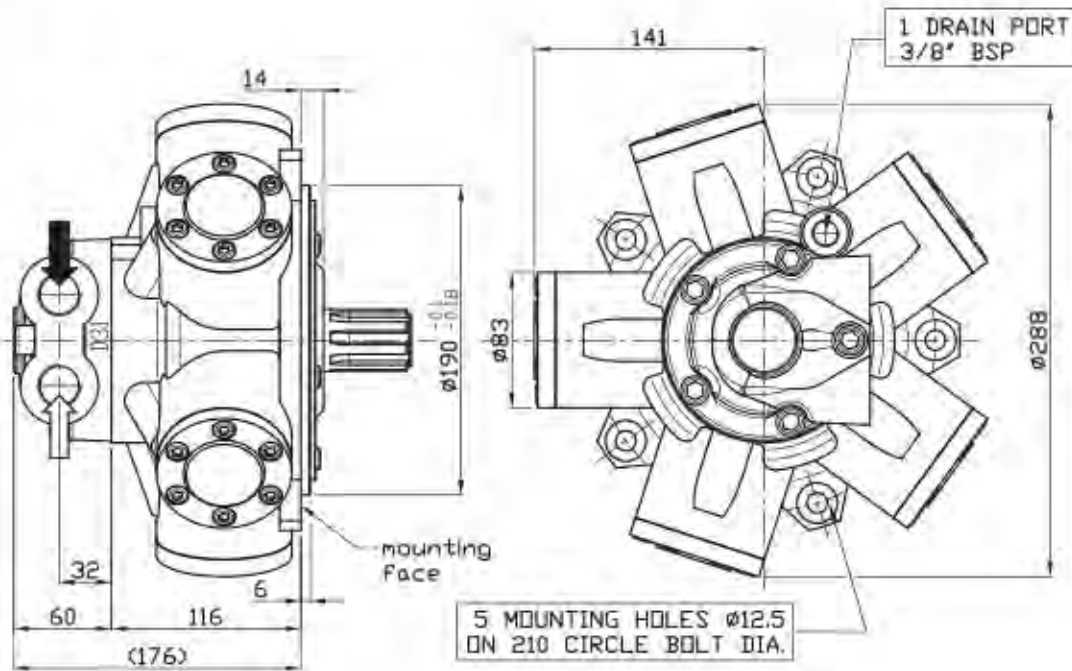

## SHAFT

### IAM 200/PH-250/PH-300/PH H1

A0: Standard splined shaft

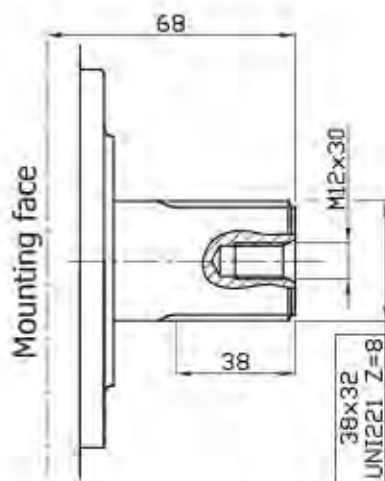



## ORDERING INSTRUCTIONS

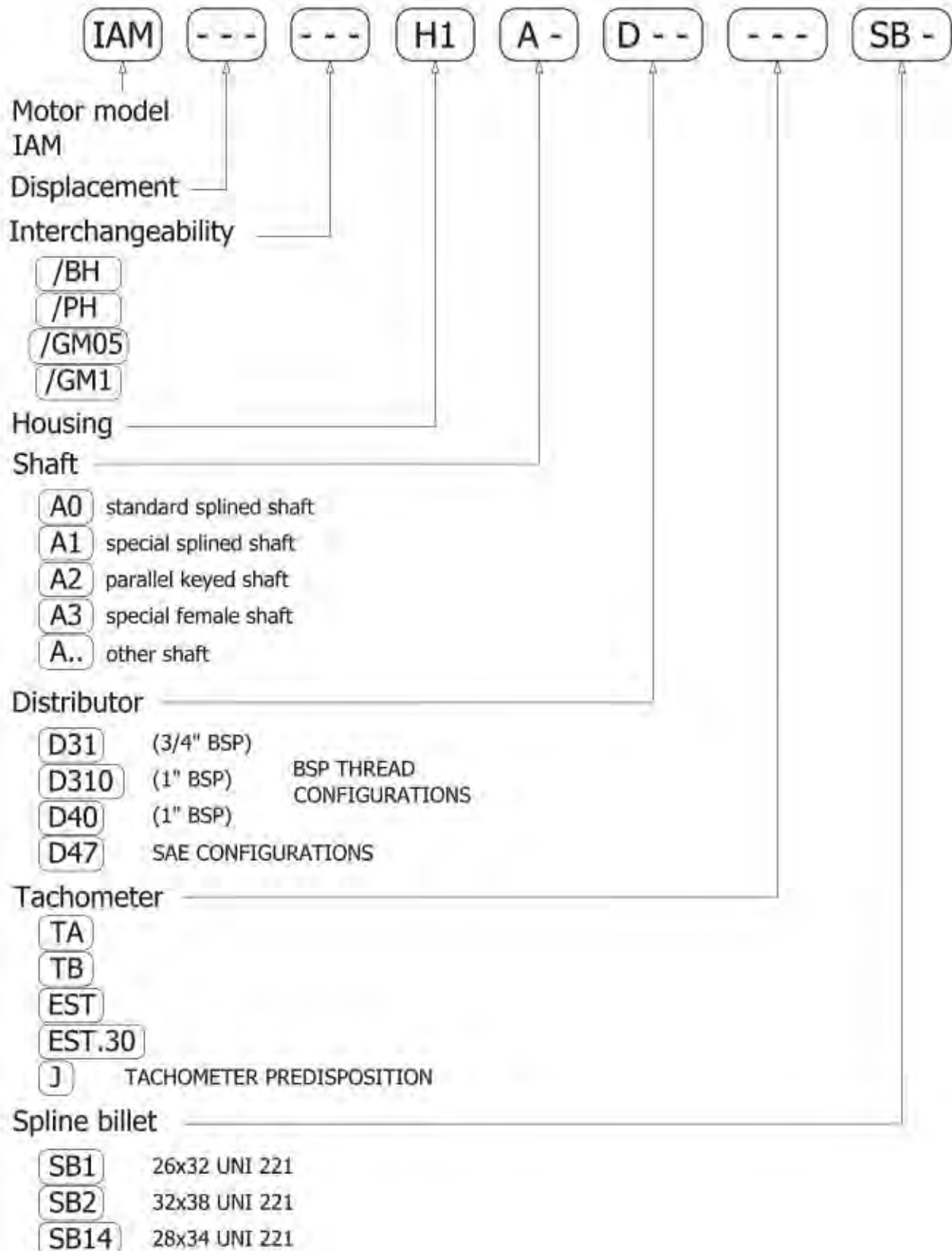

**EXAMPLE:** IAM.100/BH.H1.A0.D40.J.SB14  
IAM.250.H1.A0.D31.TA.SB2

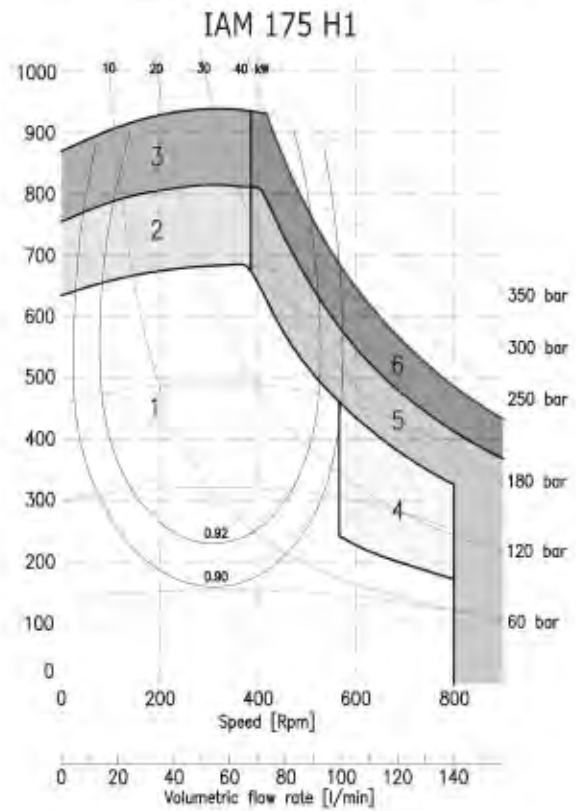
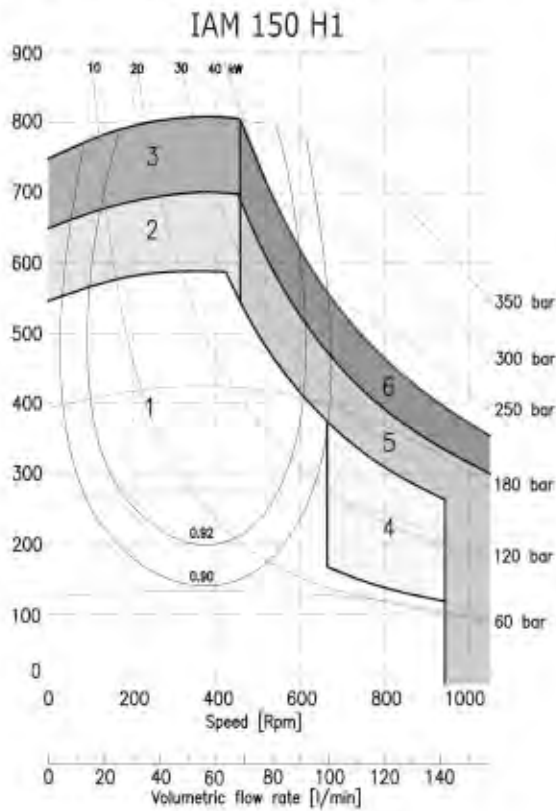
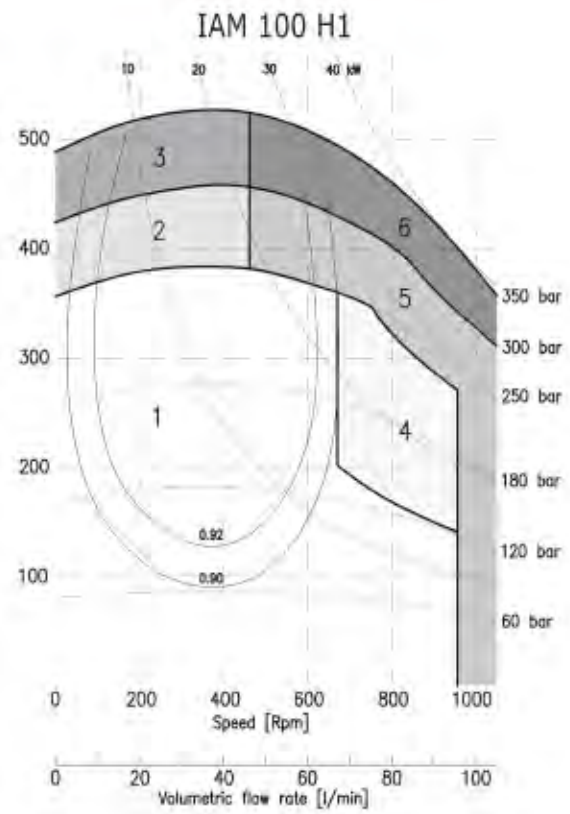
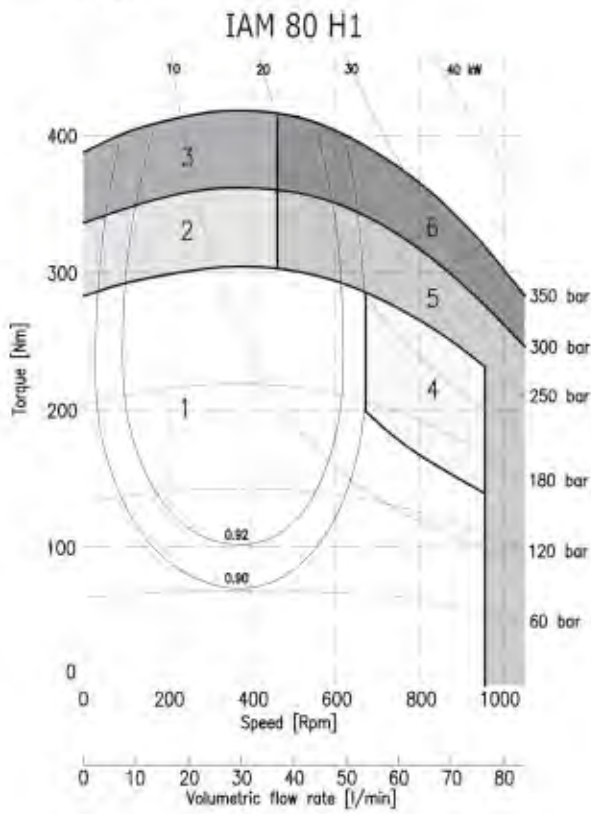

- 1 Continuous operation
- 2 Intermittent operation for period 3-5 minutes every 10-15 minutes
- 3 Intermittent operation for very short period (3-5 seconds) every 10-15 minutes

- 4 Continuous operation with flushing
- 5 Intermittent operation for period 3-5 minutes every 10-15 minutes with flushing
- 6 Intermittent operation for very short period (3-5 seconds) every 10-15 minutes with flushing



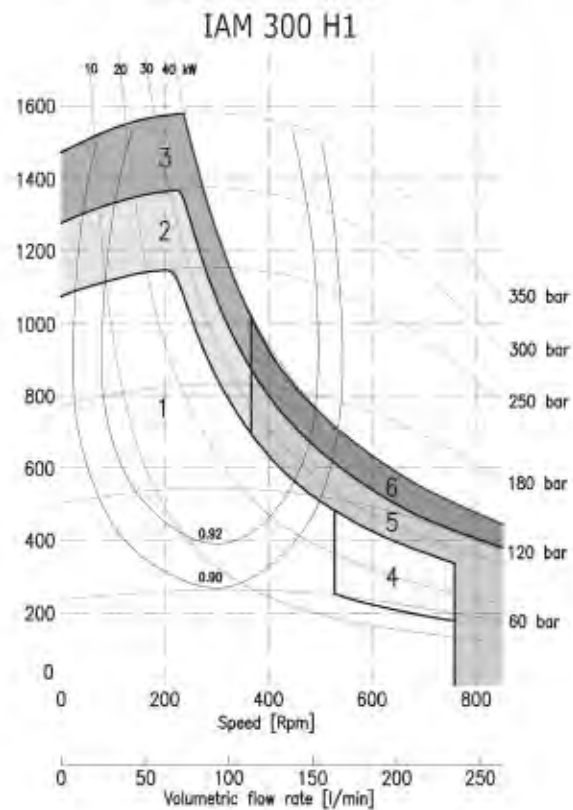
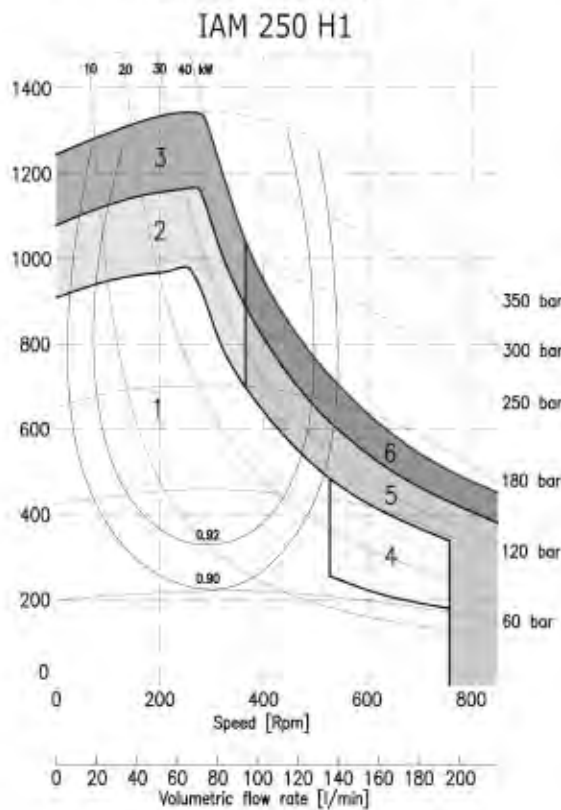
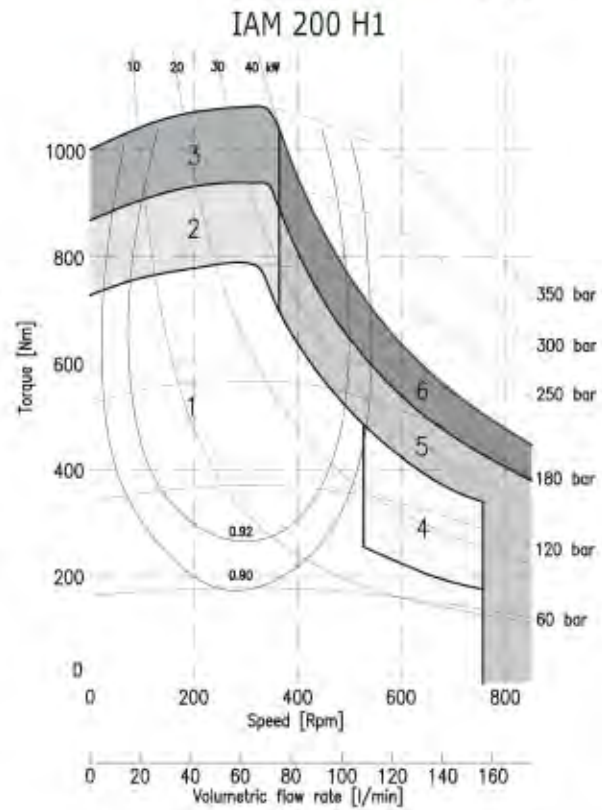
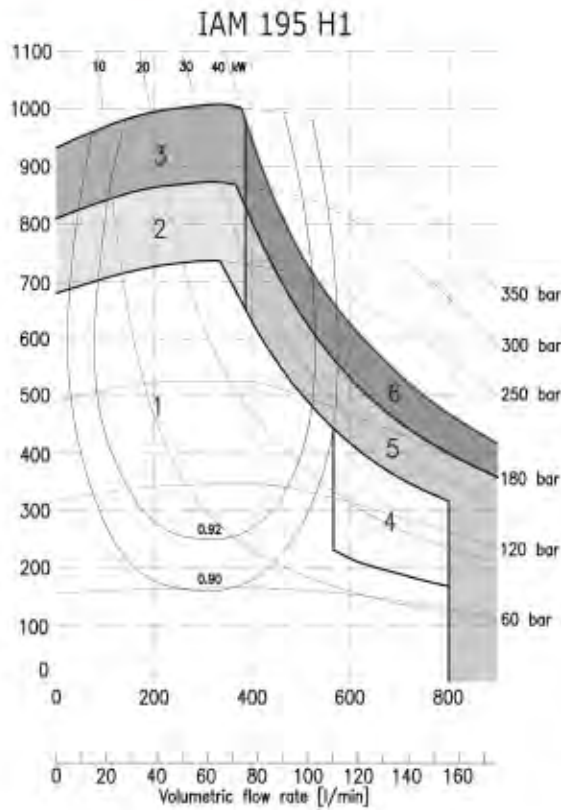

- 1 Continuous operation
- 2 Intermittent operation for period 3-5 minutes every 10-15 minutes
- 3 Intermittent operation for very short period (3-5 seconds) every 10-15 minutes

- 4 Continuous operation with flushing
- 5 Intermittent operation for period 3-5 minutes every 15-15 minutes with flushing
- 6 Intermittent operation for very short period (3-5 seconds) every 10-15 minutes with flushing





# **ITALGROUP - ADVANCED - MOTORS**

## **IAM SERIES**

### **H2 MODEL**

**IAM 200-250-300-350  
400-500-600 H2**

**IAM 190/C H2**

**IAM 300/C H2**

**IAM 200/B10 H2**

**IAM 200-250-300-350  
400-500-600/PH H2**

**IAM 200-250-300-350  
400-500-600/GM2 H2**

**IAM 200-250-300-350  
400-500-600/S H2**

### **INDEX**

TECHNICAL DATA	-----	Pag.	28
IAM H2 200-250-300-350	-----	"	29
IAM H2 400-500-600	-----	"	30
IAM H2 190/C	-----	"	31
IAM H2 300/C	-----	"	32
IAM H2 200/B10	-----	"	33
IAM H2 200-250-300-350-400-500-600/PH	-----	"	34
IAM H2 200-250-300-350-400-500-600/GM2	-----	"	35
IAM H2 200-250-300-350-400-500-600/S	-----	"	36
ORDERING INSTRUCTIONS	-----	"	37
GRAPHIC PERFORMANCES H2 200-250-300-350	-----	"	38
GRAPHIC PERFORMANCES H2 400-500-600	-----	"	39

MODEL		IAM 200 H2	IAM 250 H2	IAM 300 H2	IAM 350 H2	IAM 400 H2	IAM 500 H2	IAM 600 H2
Displacement	cc/rev	198	253	314	362	424	492	584
Specific Torque	Nm/bar	3.2	4.0	5.0	5.8	6.7	7.8	9.3
Max cont. Pressure	bar	250	250	250	250	250	250	250
Max int. Pressure	bar	300	300	300	300	300	300	300
Peak pressure	bar	350	350	350	350	350	350	350
Max continuous speed	rpm	800	750	750	650	600	500	500
Peak speed	rpm	900	850	850	750	700	600	600
Max continuous power	HP	45	45	45	45	45	45	45
	KW	33	33	33	33	33	33	33
Max power	HP	66	66	66	66	66	66	66
	KW	49	49	49	49	49	49	49

- N° of pistons: 5
- Max case pressure: 6 bar
- Max back pressure: 70 bar
- Dry weight: 42 kg
- Temperature range: -30°C ÷ +70°C
- Minimum speed: 2 rpm
- Flushing flow<sup>(\*)</sup>:
 

IAM H2 200 – 250 – 300	6 l/min
IAM H2 350 – 400 – 500	8 l/min
IAM H2 600	10 l/min

(\*)for further details regarding flushing go to page 10 of this catalogue.



## SIZE

### IAM 200-250-300-350 H2

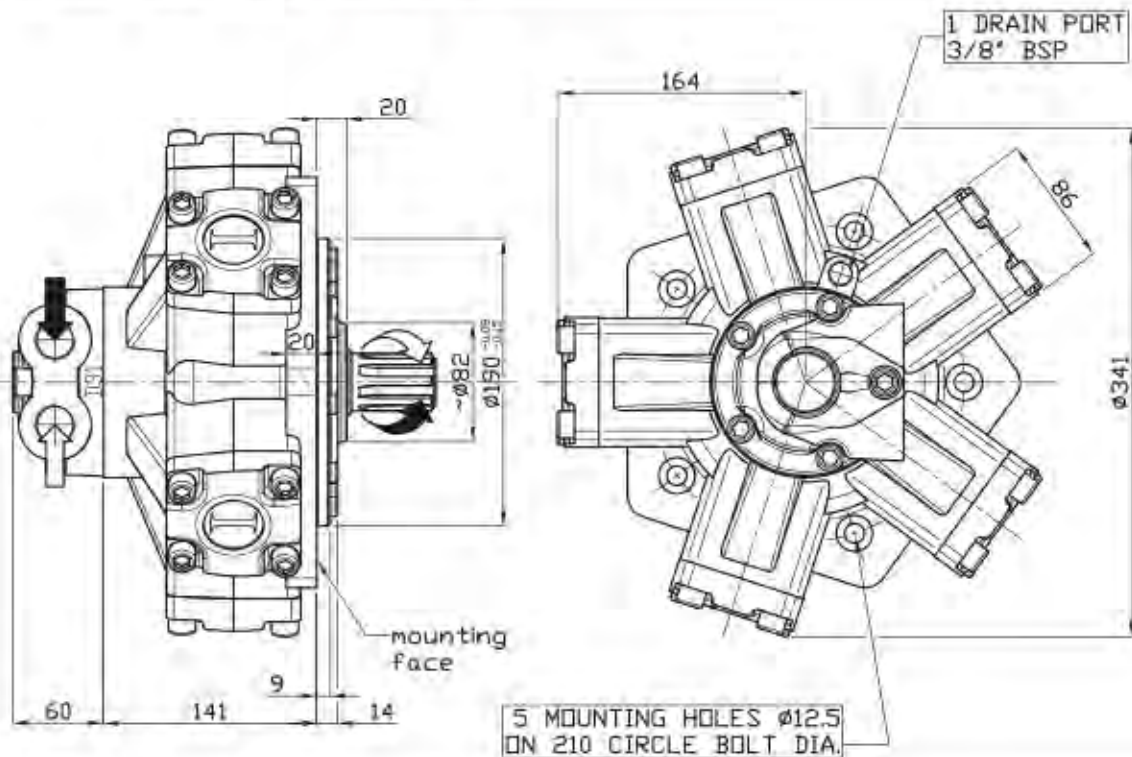

## SHAFT

### IAM 200-250-300-350 H2

A0: Standard splined shaft

A2: Parallel shaft on request

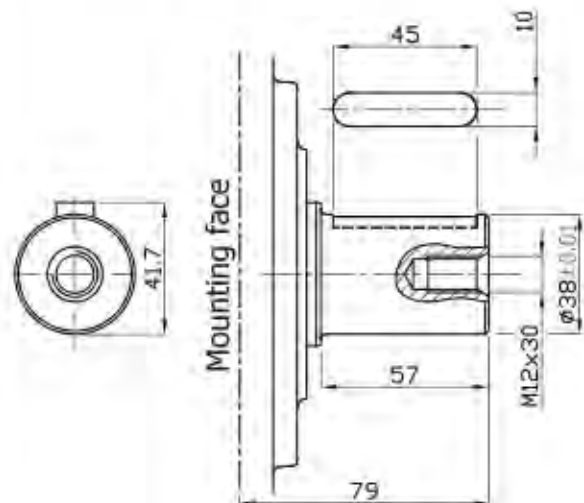
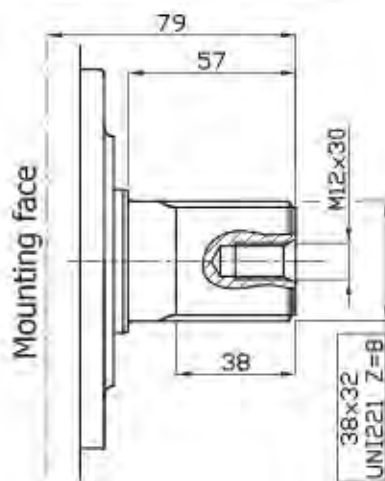

ONLY FOR IAM 300 H2: FEMALE SHAFT AVAILABLE UPON REQUEST 40x3x12x9H DIN 5480

## SIZE

### IAM 400-500-600 H2

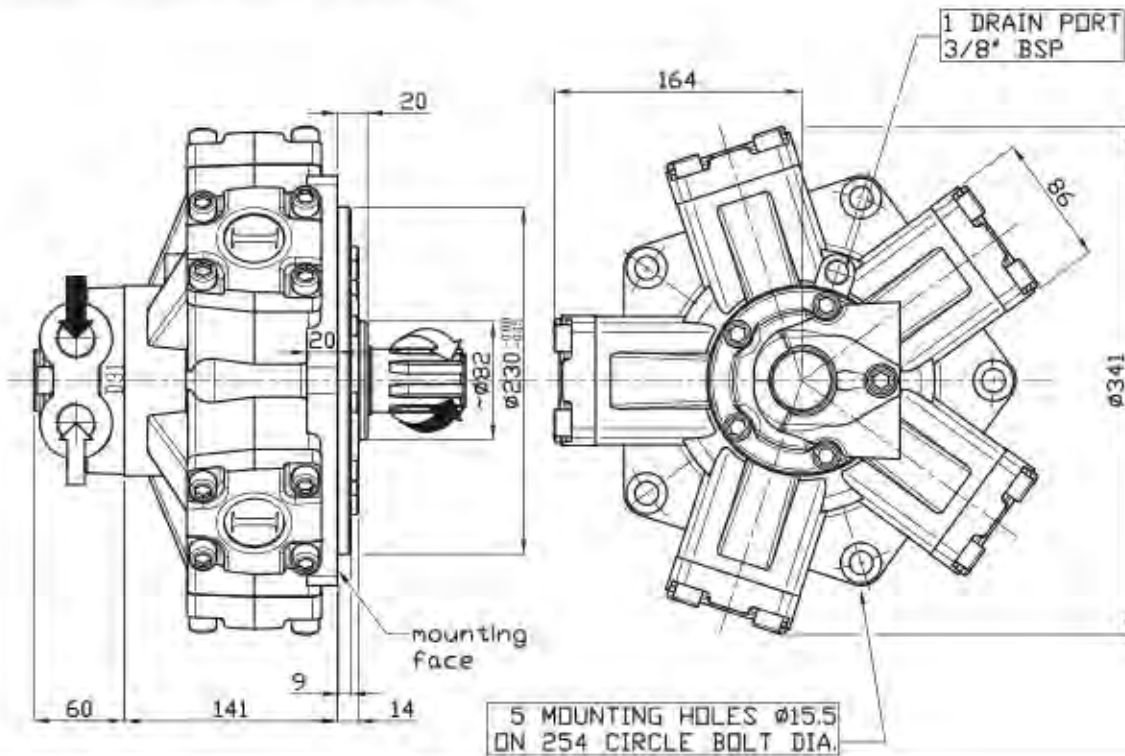

## SHAFT

### IAM 400-500-600 H2

A0: Standard splined shaft

A2: Parallel shaft on request

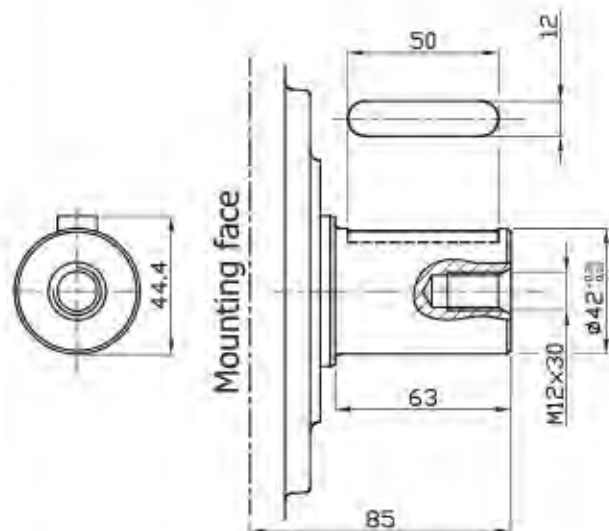
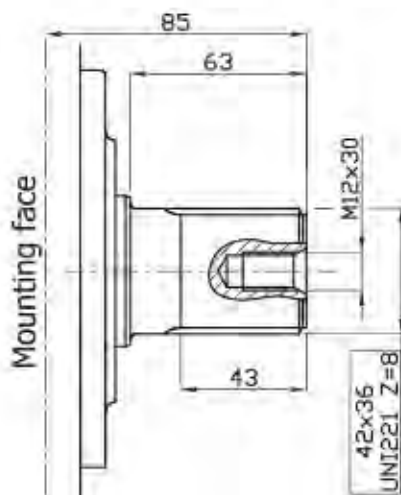



## SIZE

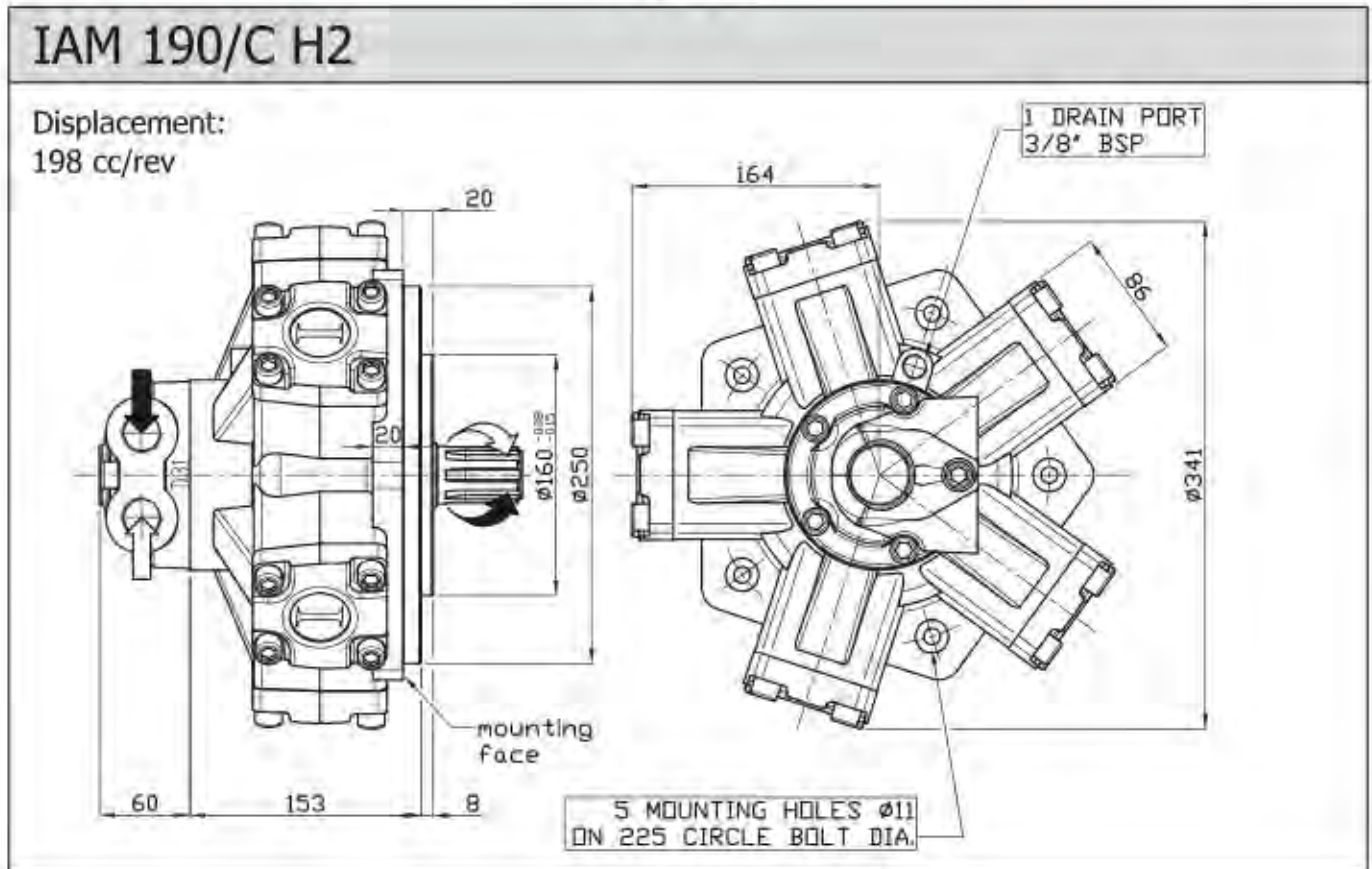

## SHAFT & OPTION

IAM 190/C H2	
A0: Standard splined shaft	FL1: connection block
	<p>Connection block, fitting D47 distributor, for motor MR 160/190/250/300</p>
A2: Parallel shaft on request	

## SIZE

### IAM 300/C H2

(available displacements:  
253 cc/Rev  
289 cc/Rev  
339 cc/Rev  
393 cc/Rev)

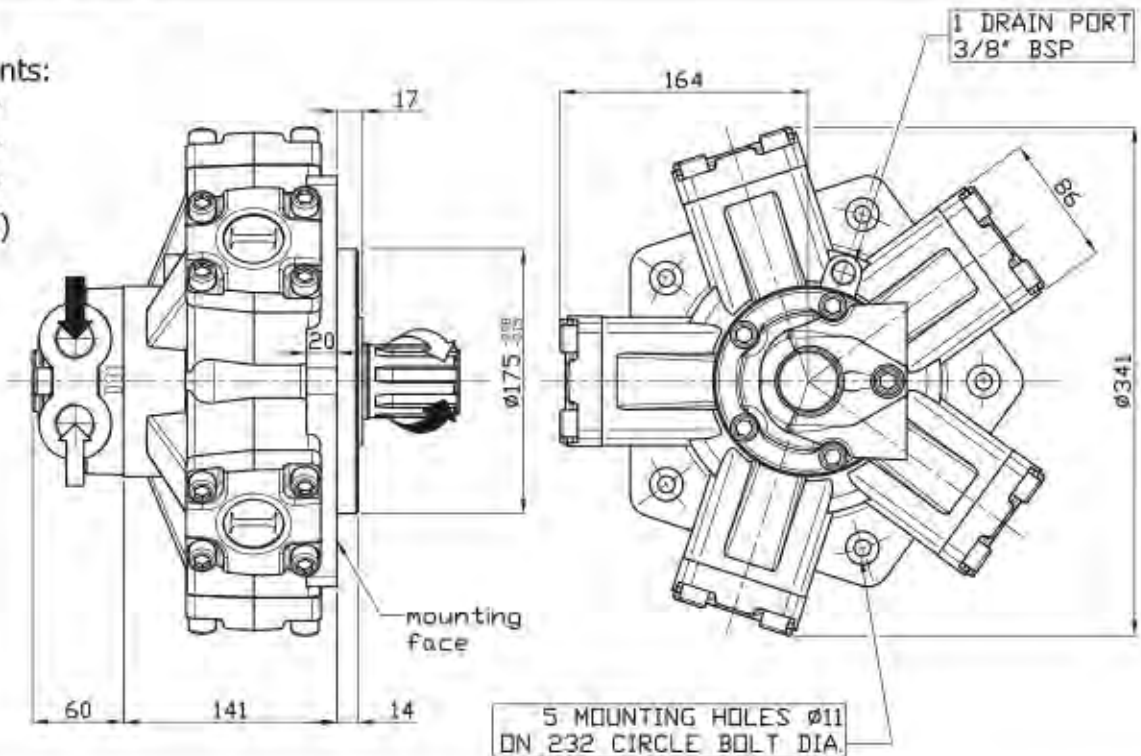

## SHAFT & OPTION

### IAM 300/C H2

A0: Standard splined shaft

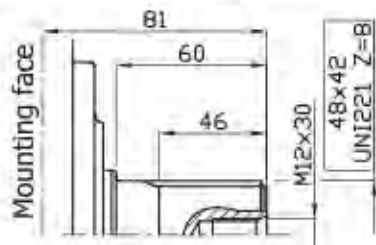

FL1: connection block

Connection block, fitting D47 distributor, for motor MR 160/190/250/300

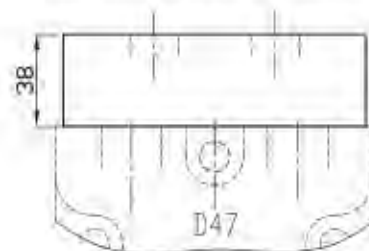

A2: Parallel shaft on request

(not available for 253 cc/Rev displacement)

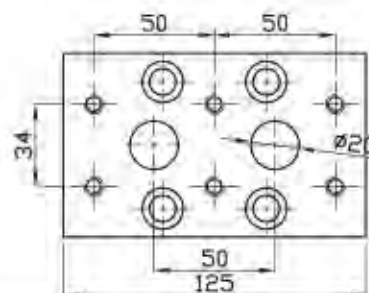
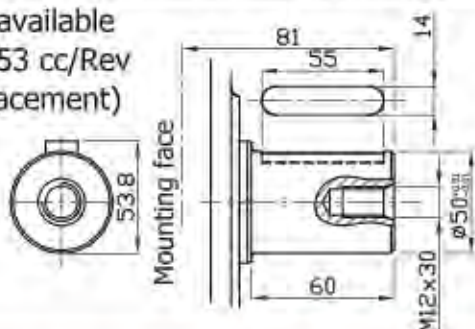



## SIZE

### IAM 200/B10 H2

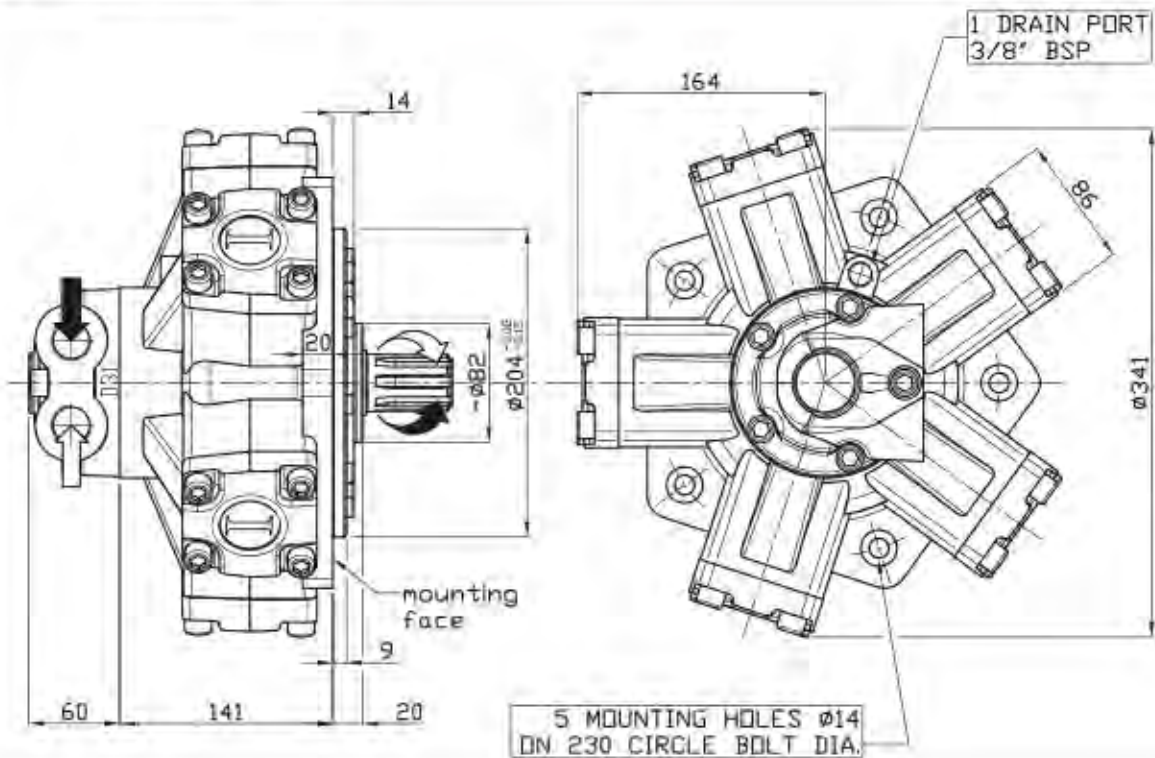

## SHAFT

### IAM 200/B10 H2

A0: Standard splined shaft

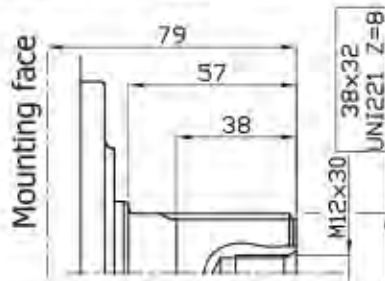

A2: Parallel shaft on request

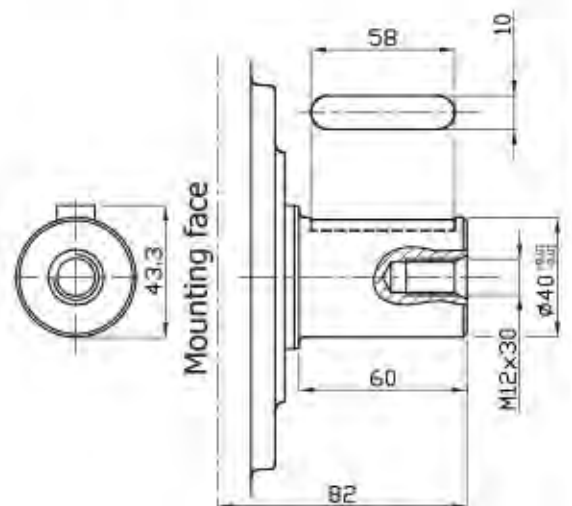

A1: Splined shaft on request

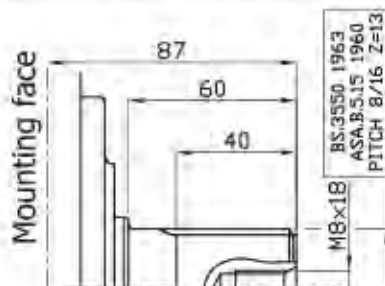

## SIZE

### IAM 200-250-300-350-400-500-600/PH H2

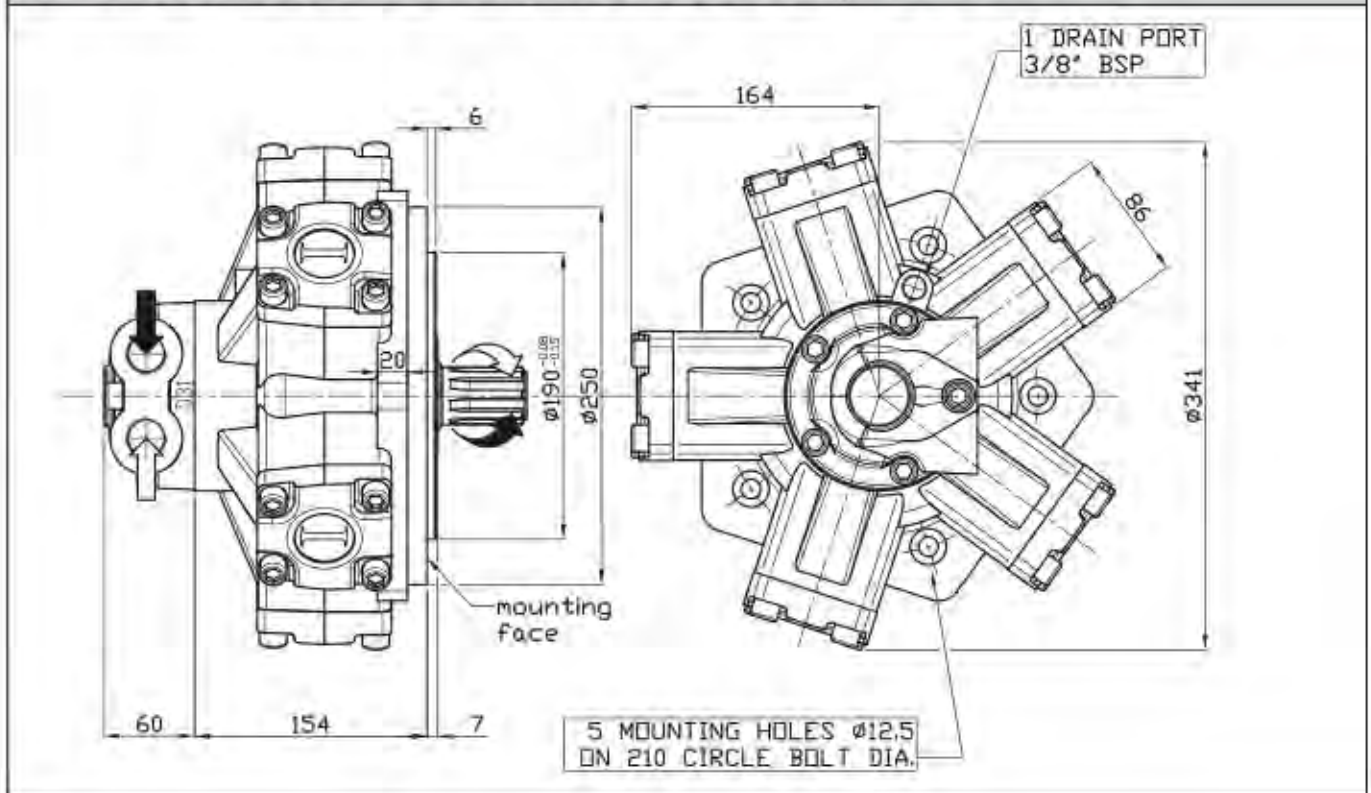

## SHAFT

### IAM 200-250-300-350-400-500-600/PH H2

A0: Standard splined shaft

A2: Parallel shaft on request

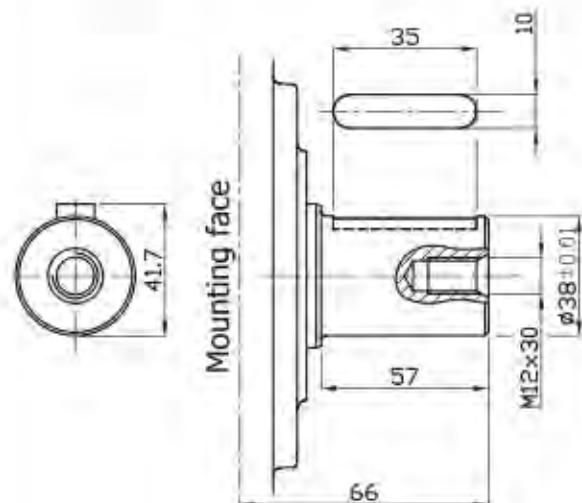
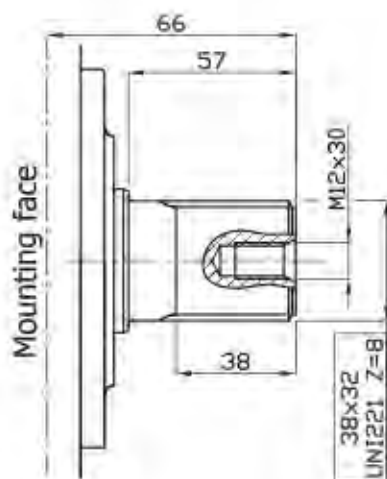



INTERCHANGEABLE WITH GM2

# SIZE

IAM 200/GM2 250/GM2 300/GM2 350/GM2 400/GM2 500/GM2 600/GM2 H2

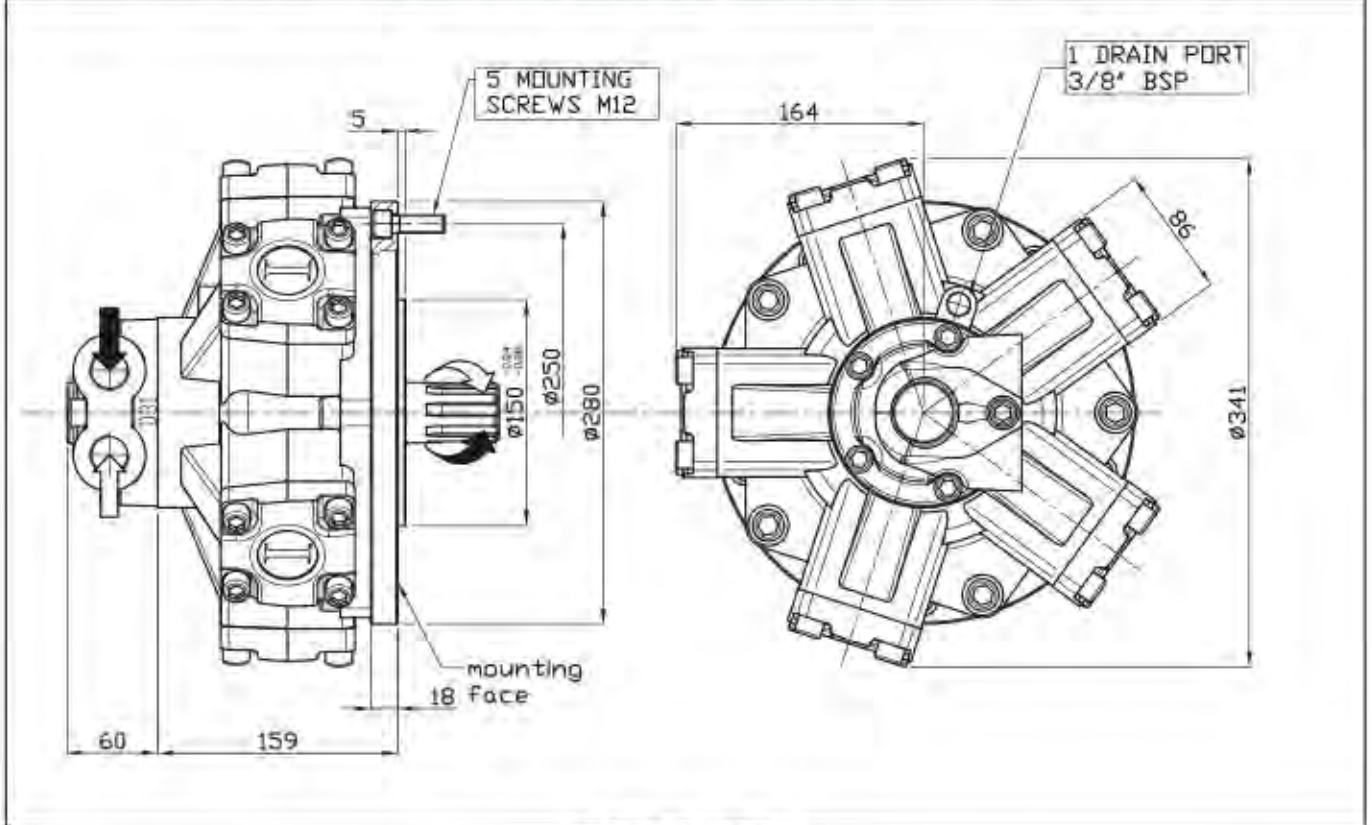

# SHAFT

IAM 200/GM2 250/GM2 300/GM2 350/GM2 400/GM2 500/GM2 600/GM2 H2

A0: Standard splined shaft

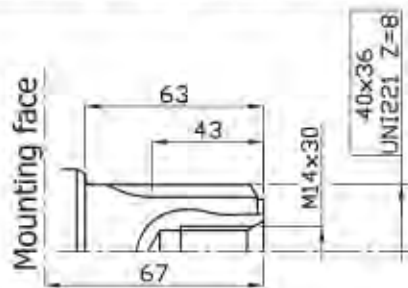

A2: Parallel shaft on request

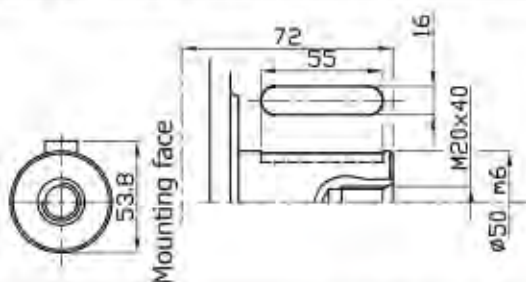

A3: Female shaft on request

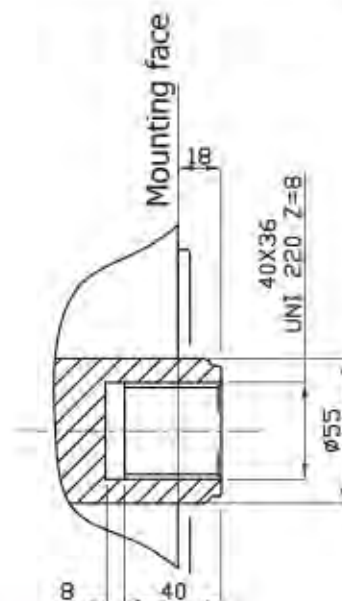

MTCP SERIES AVAILABLE ON REQUEST

The data specified into the catalogue are for product description purpose only and must not be interpreted as warranted characteristics in legal sense. ItalgrouP S.r.l. reserves the right to implement modifications without notice. All partial or total reproduction and copy without written authorization of ItalgrouP S.r.l. is strictly forbidden.

**SIZE** INTERCHANGEABLE WITH M2

**IAM 200/S 250/S 300/S 350/S 400/S 500/S 600/S H2**

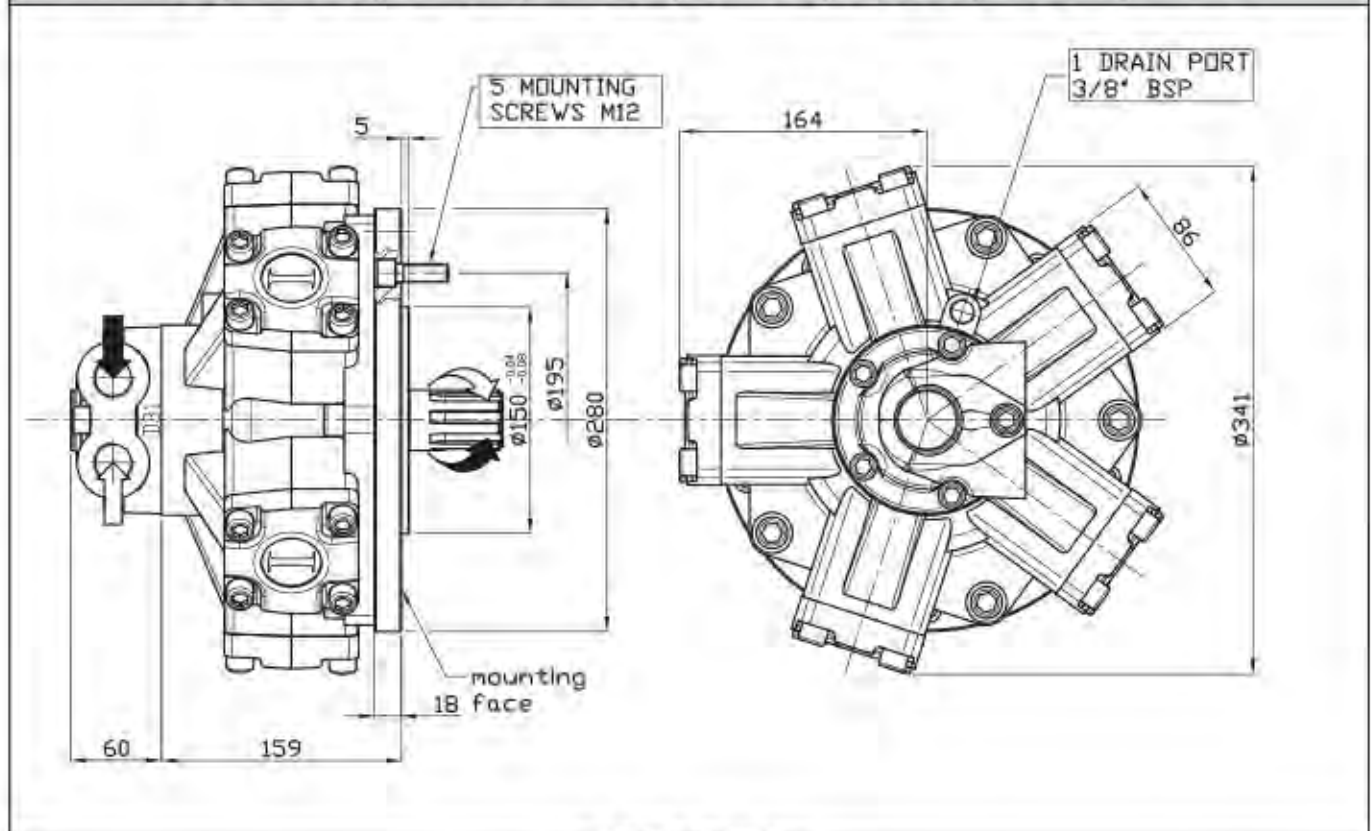

## SHAFT

**IAM 200/S 250/S 300/S 350/S 400/S 500/S 600/S H2**

**A0: Standard splined shaft**

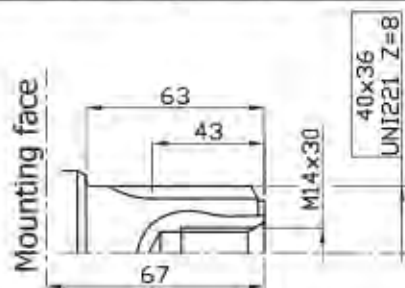

**A2: Parallel shaft on request**

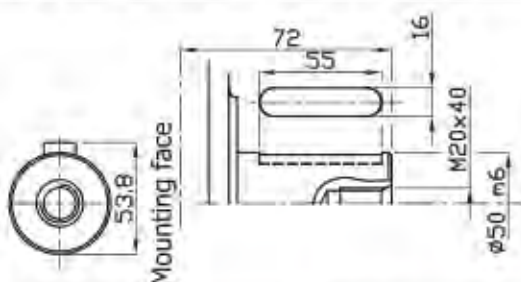

**A3: Female shaft on request**

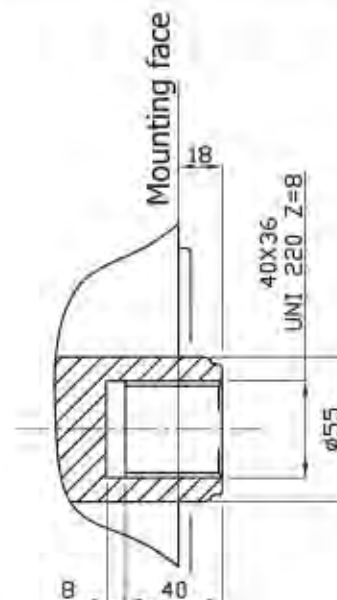

**MTCP SERIES AVAILABLE ON REQUEST**



## ORDERING INSTRUCTIONS

	<b>IAM</b>	<b>---</b>	<b>---</b>	<b>H2</b>	<b>A -</b>	<b>D - -</b>	<b>---</b>	<b>SB -</b>
Motor model	IAM							
Displacement								
Interchangeability								
	<b>/C</b> (190/C, 300/C)							
	<b>/B10</b> (200/B10)							
	<b>/PH</b>							
	<b>/GM2</b> <b>/S</b>							
Housing								
Shaft								
	<b>A0</b> standard splined shaft							
	<b>A1</b> special splined shaft							
	<b>A2</b> parallel keyed shaft							
	<b>A3</b> special female shaft							
	<b>A..</b> other shaft							
Distributor								
	<b>D31</b> (3/4" BSP)							
	<b>D310</b> (1" BSP) <b>BSP THREAD</b>							
	<b>D40</b> (1" BSP) <b>CONFIGURATIONS</b>							
	<b>D47</b> <b>SAE CONFIGURATIONS</b>							
Tachometer								
	<b>TA</b>							
	<b>TB</b>							
	<b>EST</b>							
	<b>EST.30</b>							
	<b>J</b> TACHOMETER PREDISPOSITION							
Spline billet								
	<b>SB2</b> 32x38 UNI 221							
	<b>SB3</b> 36x42 UNI 221							
	<b>SB15</b> 42x48 UNI 222							

**EXAMPLE:** IAM.200.H2.A0.D40  
IAM.190/C.H2.A0.D47.J  
IAM.200/B10.H2.A0.D31.TA

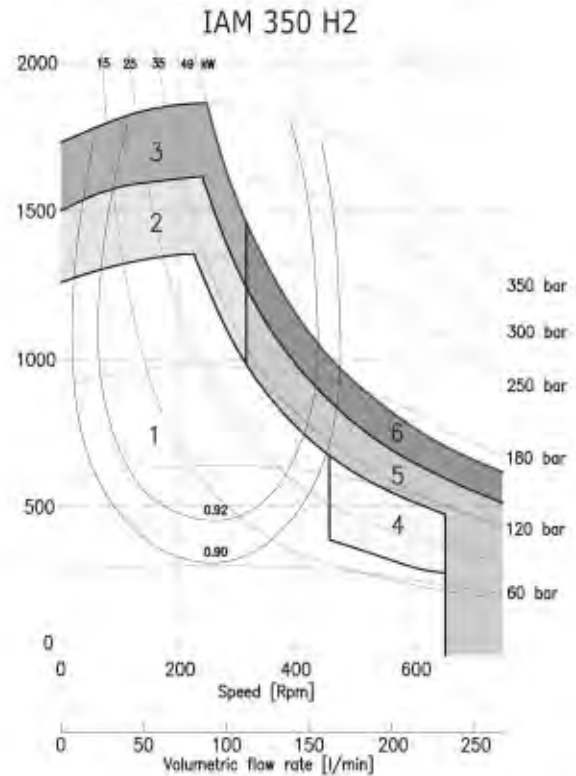
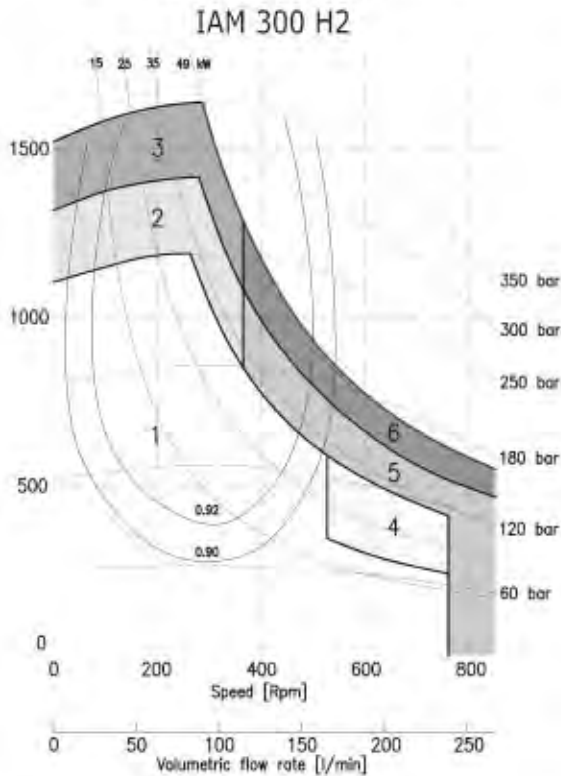
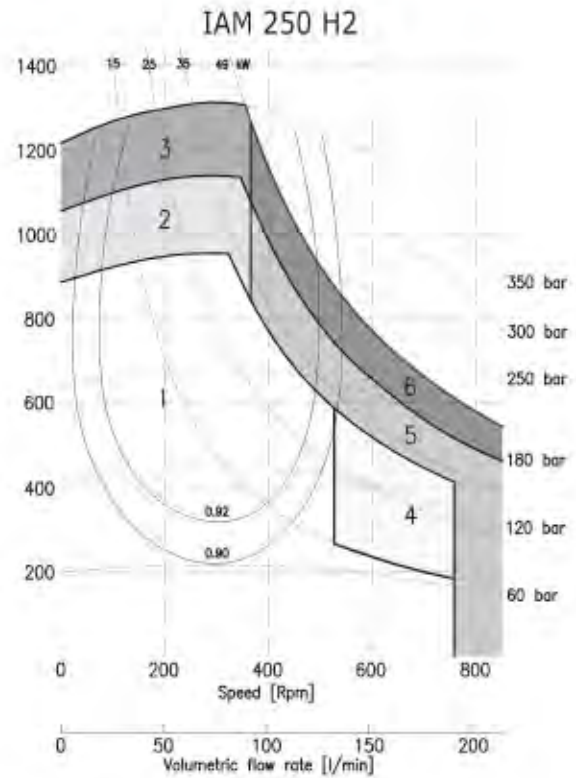
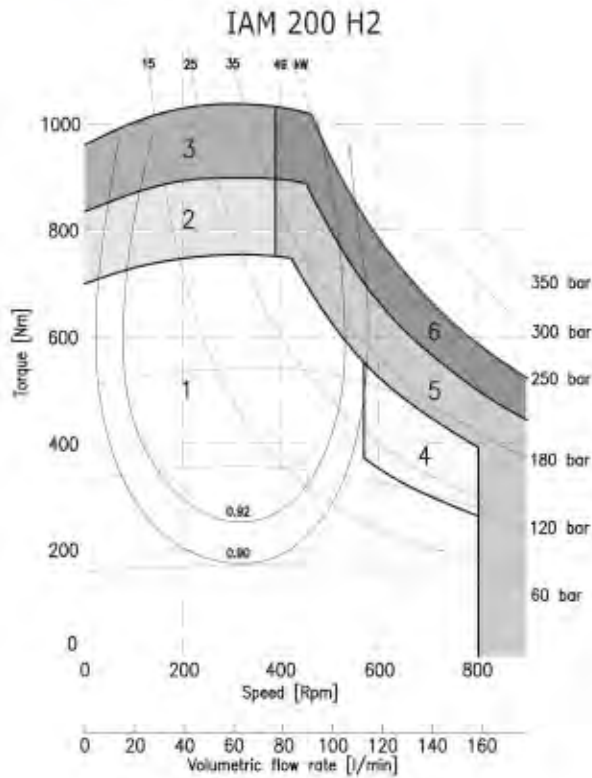

- 1 Continuous operation
- 2 Intermittent operation for period 1-5 minutes every 10-15 minutes
- 3 Intermittent operation for very short period (1-5 seconds every 10-15 minutes)

- 4 Continuous operation with flushing
- 5 Intermittent operation for period 3-5 minutes every 10-15 minutes with flushing
- 6 Intermittent operation for very short period (3-5 seconds every 10-15 minutes) with flushing



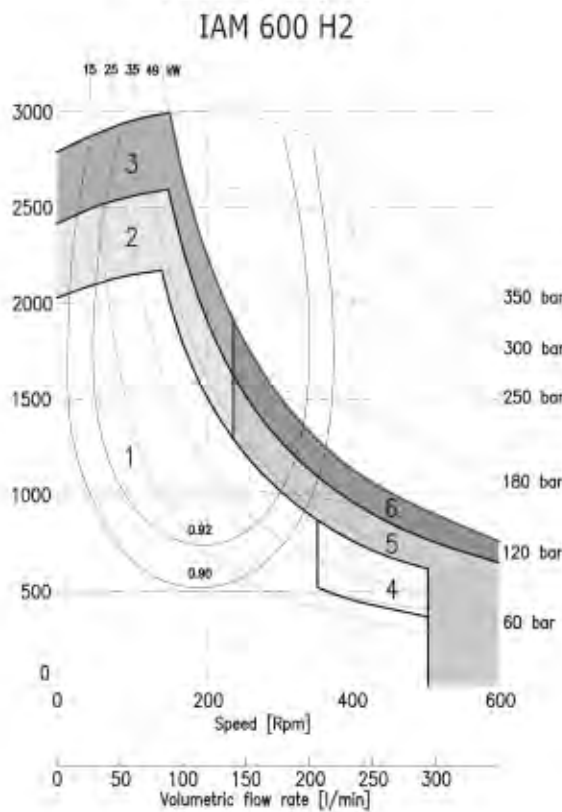
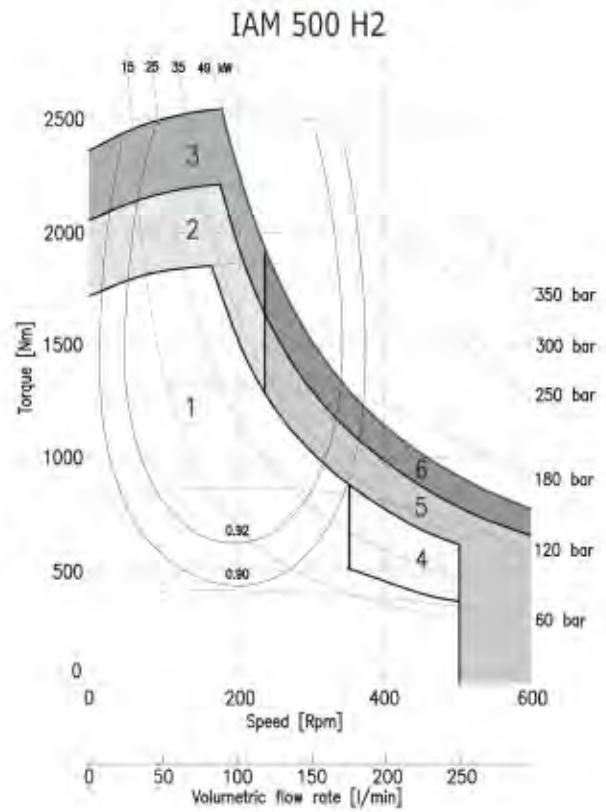
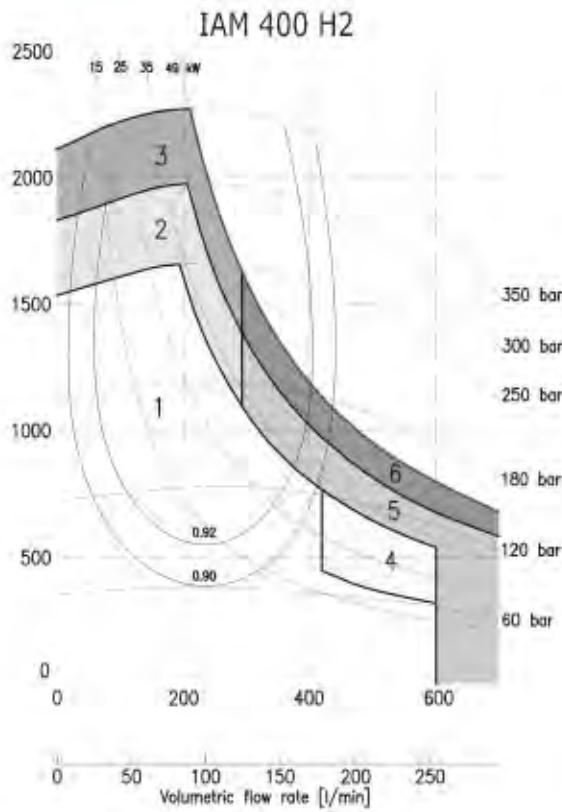

- |   |  |
|---|--|
| 1 | Continuous operation   |
| 2 | Intermittent operation for period 3-5 minutes every 10-15 minutes              |
| 3 | Intermittent operation for very short period (3-5 seconds) every 10-15 minutes |

- |   |  |
|---|--|
| 4 | Continuous operation with flushing   |
| 5 | Intermittent operation for period 3-5 minutes every 10-15 minutes with flushing              |
| 6 | Intermittent operation for very short period (3-5 seconds) every 10-15 minutes with flushing |





---

**ITALGROUP - ADVANCED - MOTORS****IAM SERIES****H3 MODEL**

---

**IAM 350-400-450-500  
600-650-700 H3****IAM 450/C H3****IAM 450/B30 H3****IAM 800 H3****IAM 800/N H3****IAM 400-450-500  
600-700/GM3 H3****IAM 400-450-500  
600-700/S H3**

---

**INDEX**

TECHNICAL DATA - - - - -	Pag.	42
IAM H3 350-400-450-500-600-650-700 - - - - -	"	43
IAM H3 450/C - - - - -	"	44
IAM H3 450/B30 - - - - -	"	45
IAM H3 800 - - - - -	"	46
IAM H3 800/N - - - - -	"	47
IAM H3 400-450-500-600-700/GM3 - - - - -	"	48
IAM H3 400-450-500-600-700/S - - - - -	"	49
ORDERING INSTRUCTIONS - - - - -	"	50
GRAPHIC PERFORMANCES H3 350-400-450-500 - - - - -	"	51
GRAPHIC PERFORMANCES H3 600-650-700-800 - - - - -	"	52

---

	MODEL	IAM 350 H3	IAM 400 H3	IAM 450 H3	IAM 500 H3	IAM 600 H3	IAM 650 H3	IAM 700 H3	IAM 800 H3
Displacement	cc/rev	349	397	452	491	594	660	707	791
Specific Torque	Nm/bar	5.6	6.3	7.2	7.8	9.4	10.5	11.2	12.6
Max cont. Pressure	bar	250	250	250	250	250	250	250	250
Max int. Pressure	bar	300	300	300	300	300	300	300	300
Peak pressure	bar	350	350	350	350	350	350	350	350
Max continuous speed	rpm	630	600	600	600	550	500	450	400
Peak speed	rpm	700	680	680	680	630	580	500	450
Max continuous power	HP	63	63	63	63	63	63	63	63
	kW	45	45	45	45	45	45	45	45
Max power	HP	91	91	91	91	91	91	91	91
	kW	68	68	68	68	68	68	68	68

- N° of pistons: 5
- Max case pressure: 6 bar
- Max back pressure: 70 bar
- Dry weight: 68 kg
- Temperature range: -30°C ÷ +70°C
- Minimum speed: 1 rpm
- Flushing flow<sup>(\*)</sup>:
 

IAM H3 350 – 400 – 450 – 500	8 l/min
IAM H3 600 – 650 – 700 – 800	10 l/min

(\*)for further details regarding flushing go to page 10 of this catalogue.



## SIZE

### IAM 350-400-450-500-600-650-700 H3

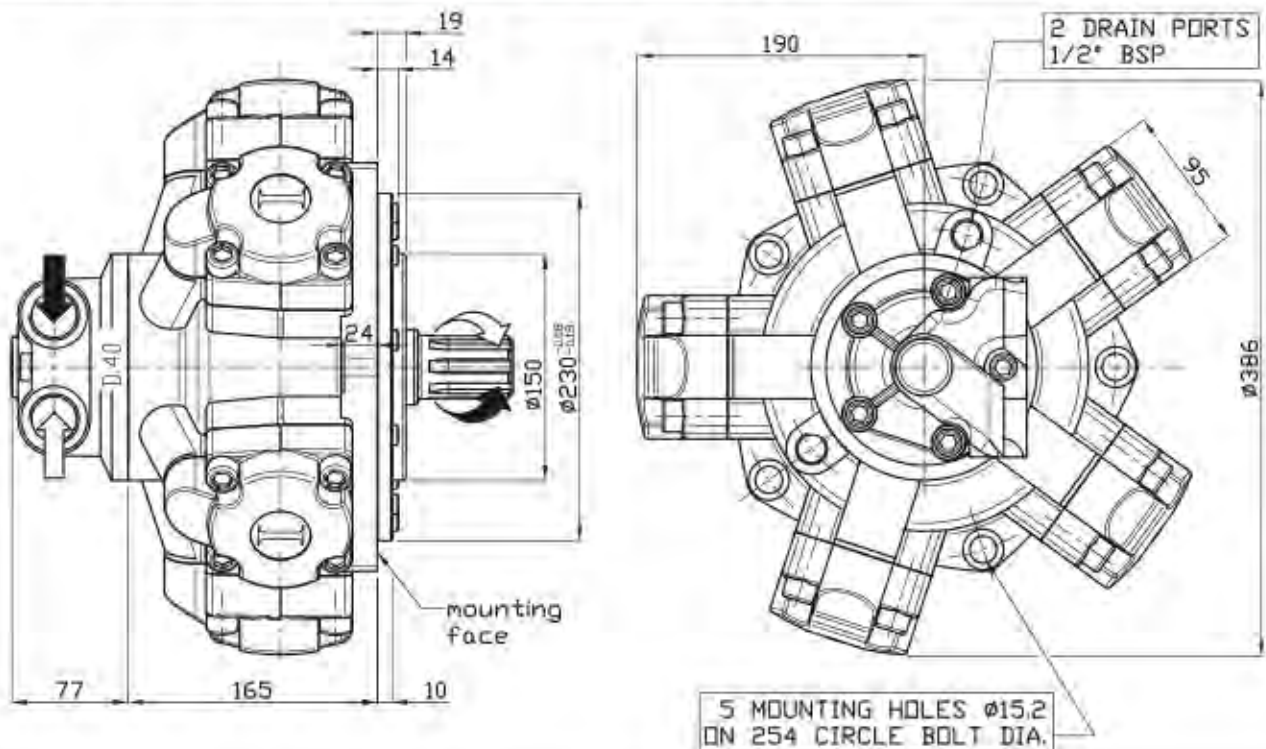

## SHAFT

### IAM 350-400-450-500-600-650-700 H3

A0: Standard splined shaft

A2: Parallel shaft on request

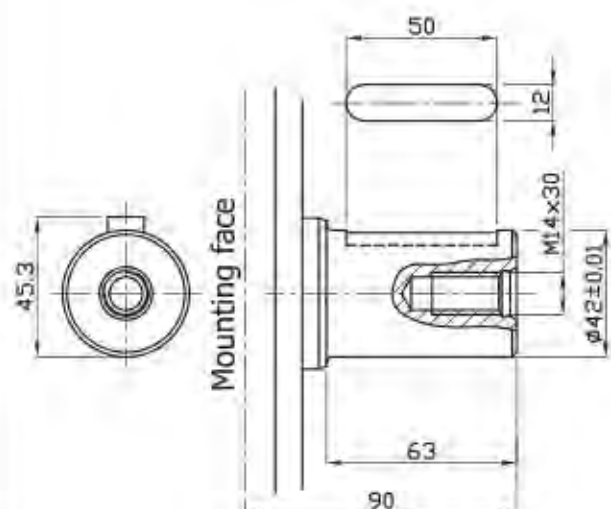
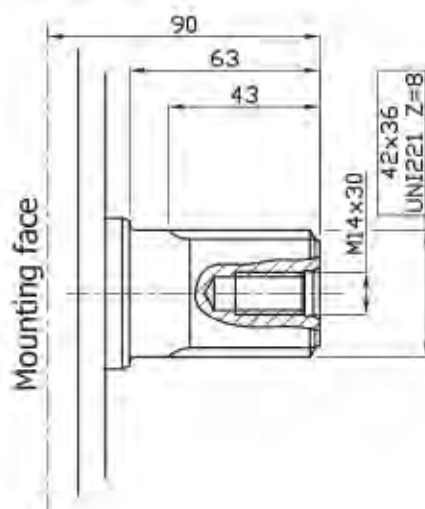

IAM 350 H3 A0 AVAILABLE ON REQUEST

## SIZE

### IAM 450/C H3

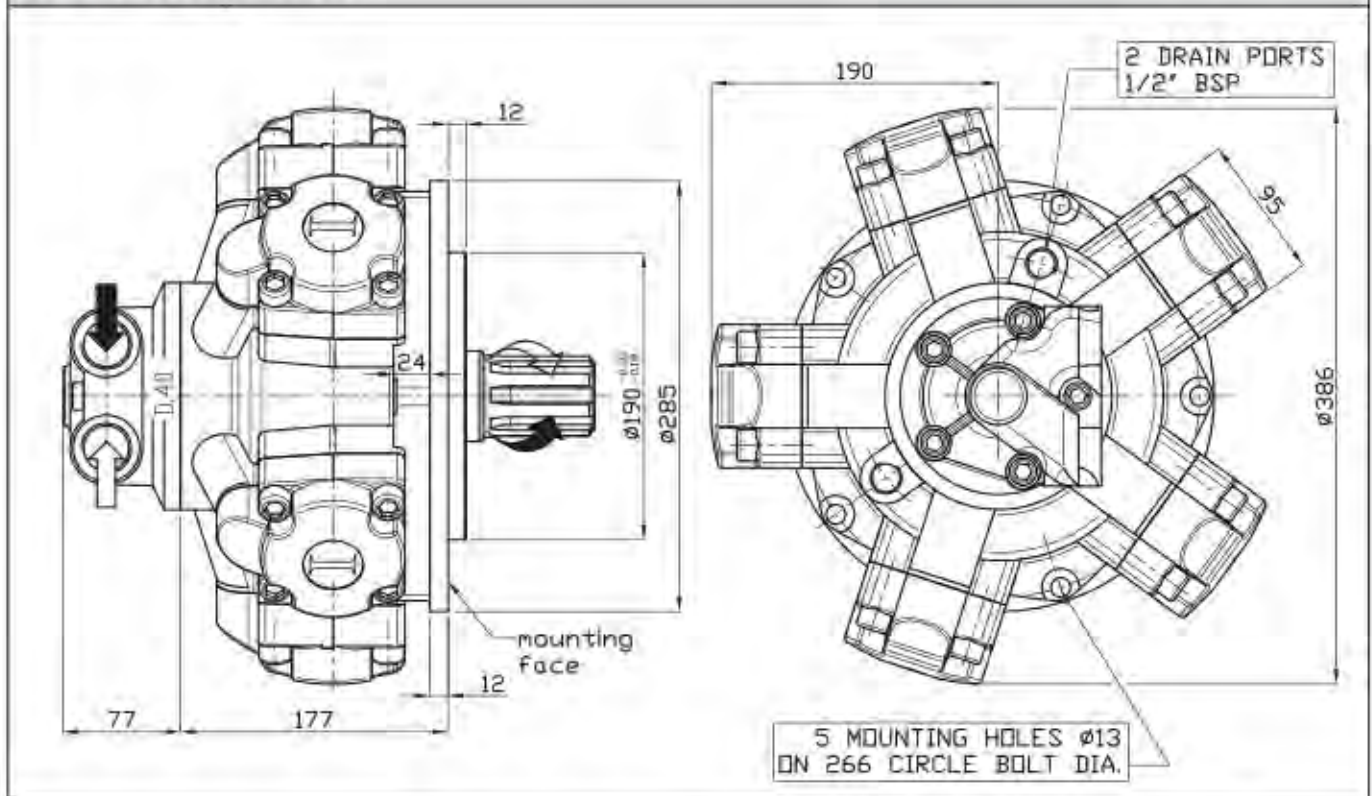

## SHAFT & OPTION

### IAM 450/C H3

A1: Standard splined shaft

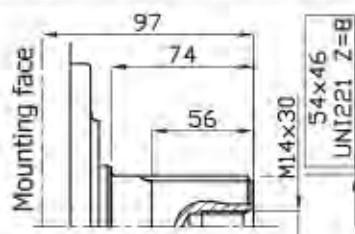

A2: Parallel shaft on request

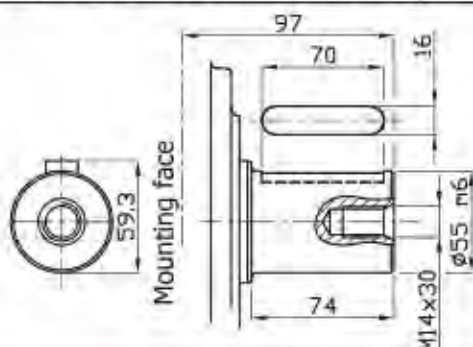

FL2: connection block

Connection block, fitting D47 distributor, for motor MR 350/450/500/600/700/800

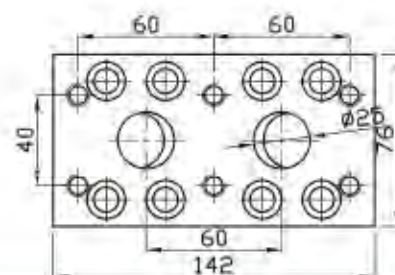
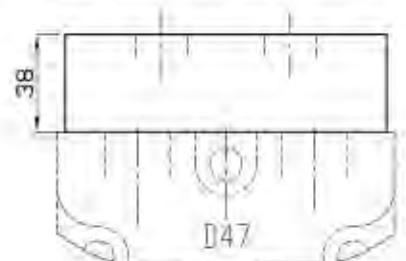



## SIZE

### IAM 450/B30 H3

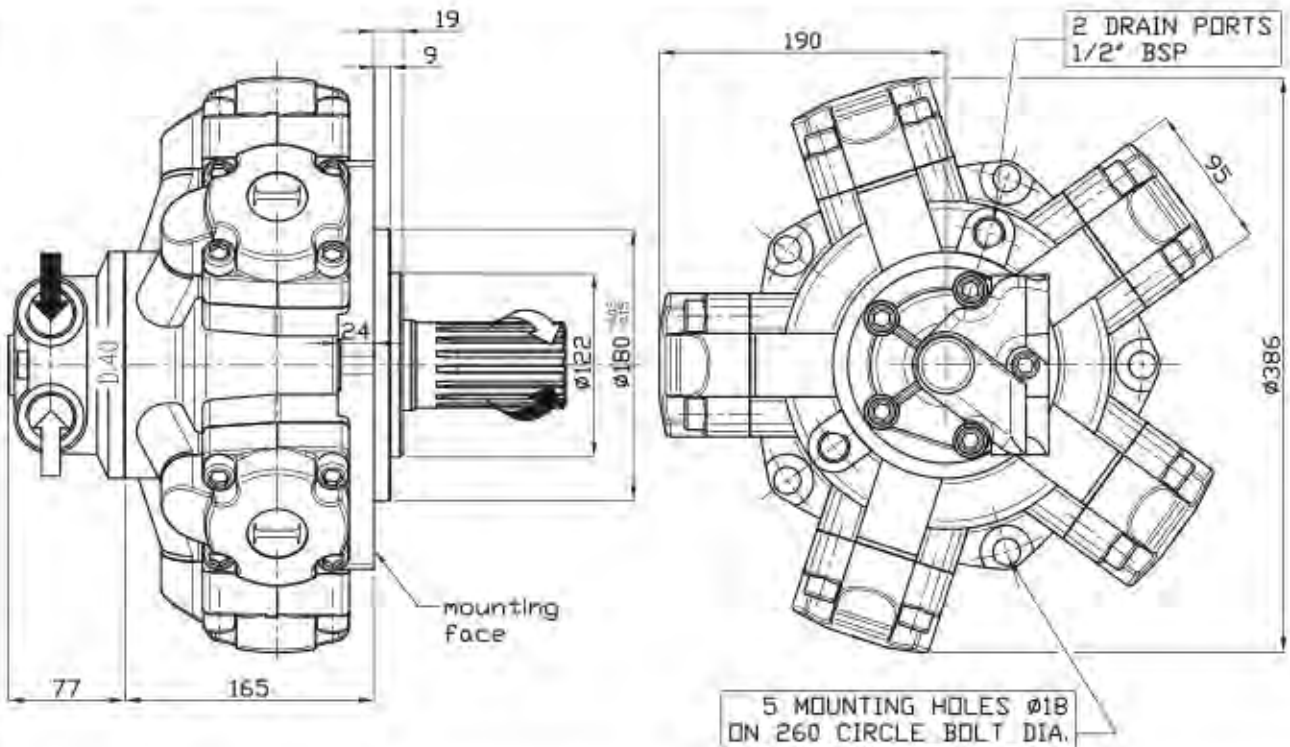

## SHAFT

### IAM 450/B30 H3

A0: Standard splined shaft

A1: Splined shaft on request

A2: Parallel shaft on request

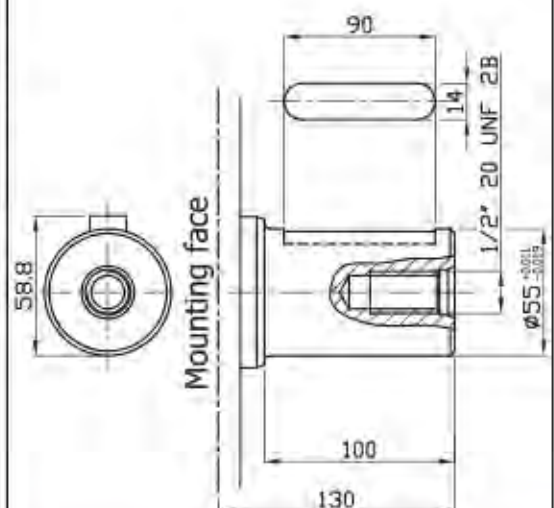
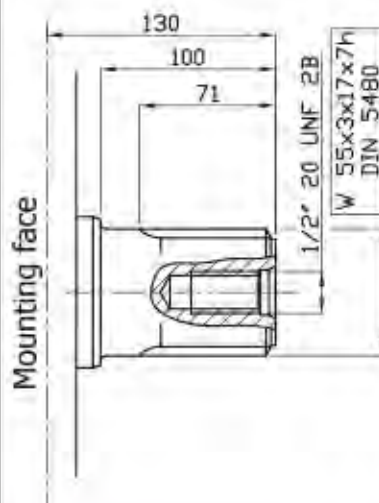
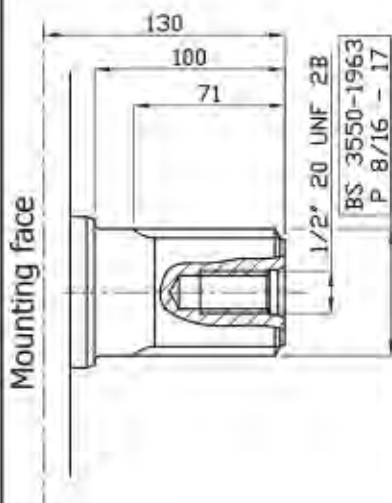



## SIZE

### IAM 800 H3

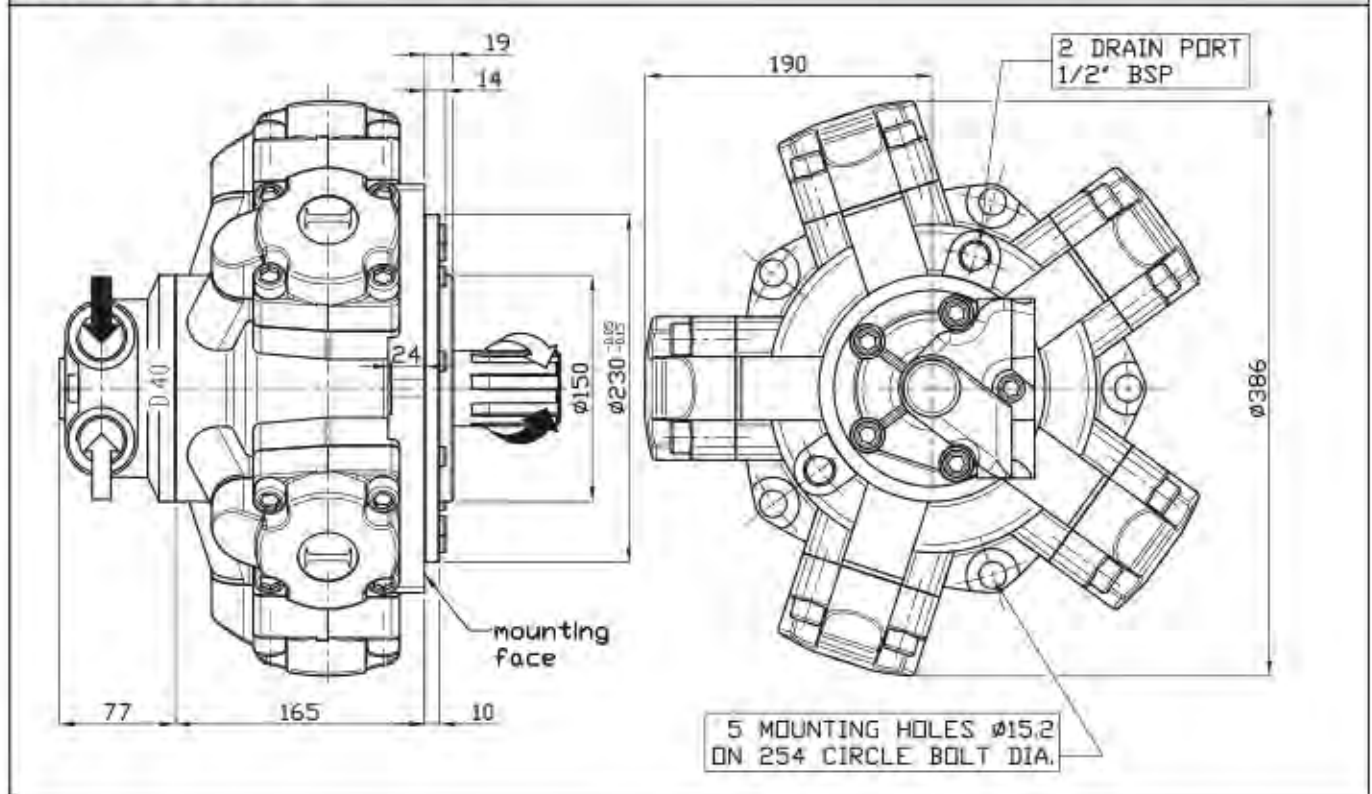

## SHAFT

### IAM 800 H3

A0: Standard splined shaft	A2: Parallel shaft on request	A22: Parallel shaft on request
<p>Technical drawing of a standard splined shaft (A0). Dimensions include a total length of 90, a splined section length of 47, a splined diameter of 50x46 UNI 220 Z=8, and a thread of M14x30. The mounting face is indicated.</p>	<p>Technical drawing of a parallel shaft (A2). Dimensions include a total length of 90, a shaft diameter of 50, a thread of M14x30, and a tolerance of <math>\phi 42 \pm 0.01</math>. The mounting face is indicated.</p>	<p>Technical drawing of a parallel shaft (A22). Dimensions include a total length of 90, a shaft diameter of 60, a thread of M14x30, and a tolerance of <math>\phi 50 \pm 0.01</math>. The mounting face is indicated.</p>

## SIZE

### IAM 800/N H3

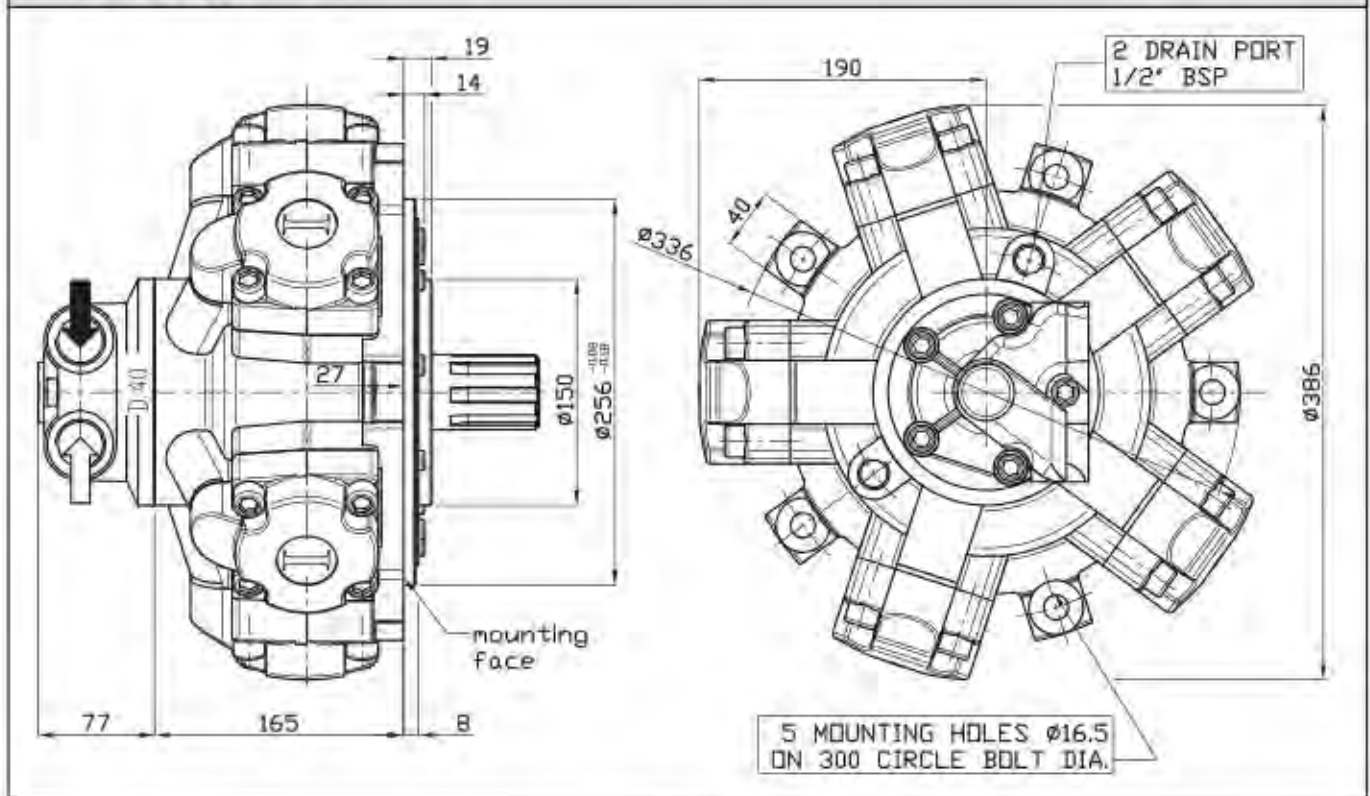

## SHAFT

### IAM 800/N H3

A1: Standard splined shaft	A2: Parallel shaft on request	A22: Parallel shaft on request
<p>Technical drawing of a standard splined shaft. Dimensions: 90, 47, M14x30, 50x46, UNI 220 Z=8. The "Mounting face" is indicated.</p>	<p>Technical drawing of a parallel shaft. Dimensions: 50, 12, M14x30, 63, 90, <math>\phi 42 \pm 0.01</math>. The "Mounting face" is indicated.</p>	<p>Technical drawing of a parallel shaft. Dimensions: 60, 16, M14x30, 90, <math>\phi 50</math>. The "Mounting face" is indicated.</p>



### IAM 400/GM3 450/GM3 500/GM3 600/GM3 700/GM3 H3

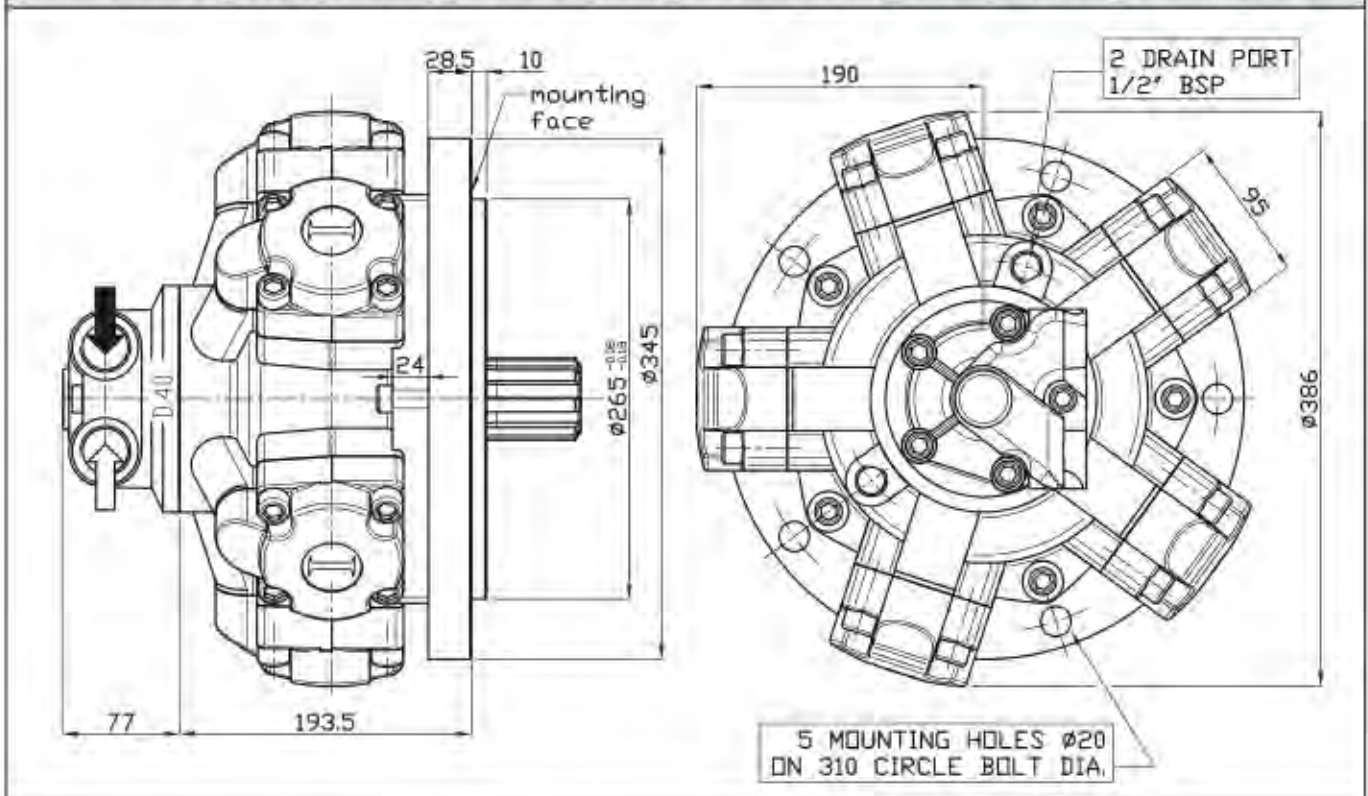

## SHAFT

### IAM 400/GM3 450/GM3 500/GM3 600/GM3 700/GM3 H3

A0: Standard splined shaft

A3: Female shaft on request

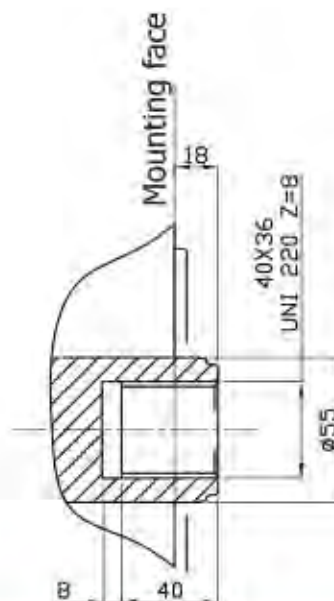
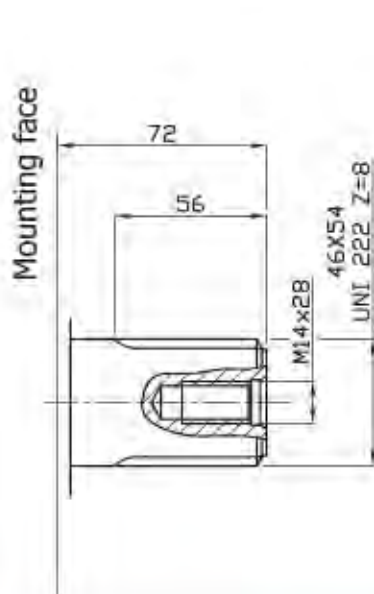



## SIZE INTERCHANGEABLE WITH M3

### IAM 400/S 450/S 500/S 600/S 700/S H3

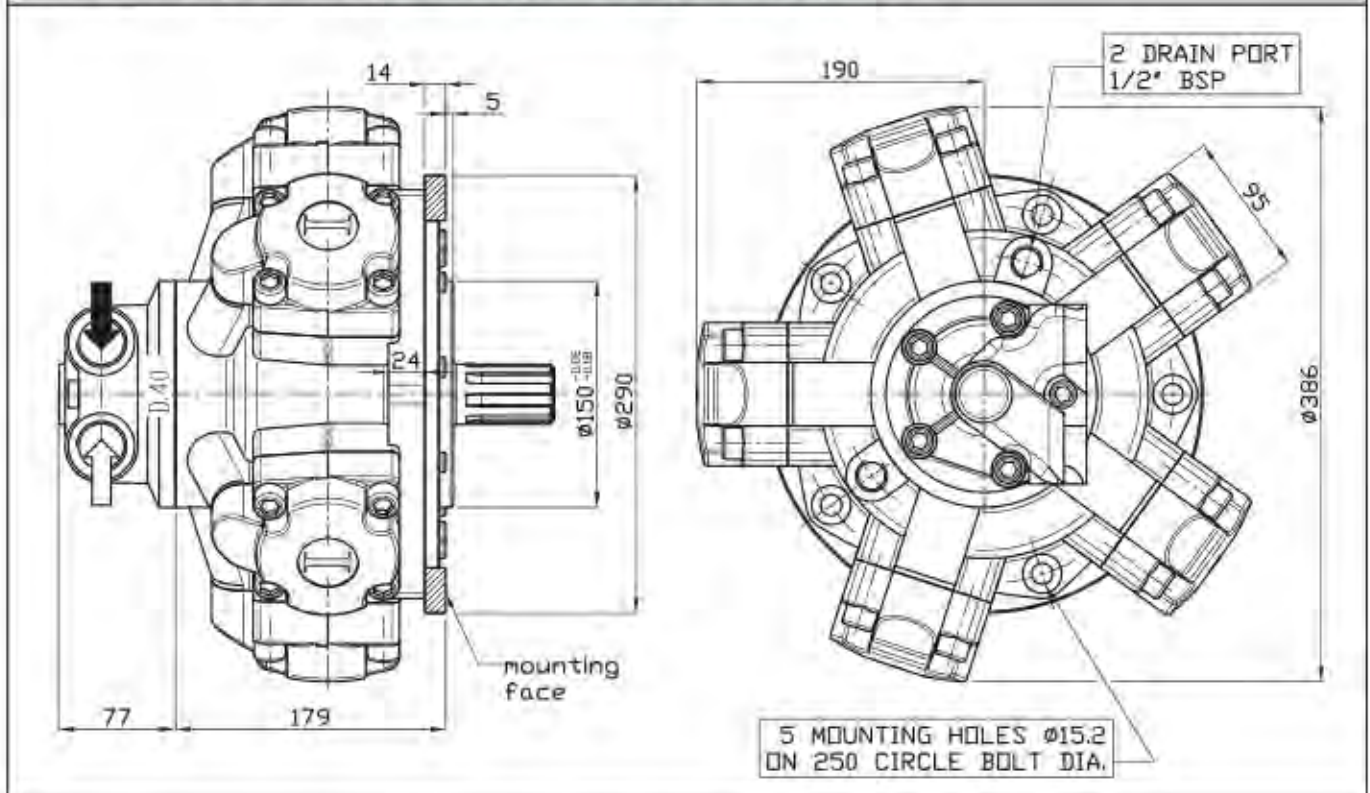

## SHAFT

### IAM 400/S 450/S 500/S 600/S 700/S H3

A0: Standard splined shaft

A3: Female shaft on request

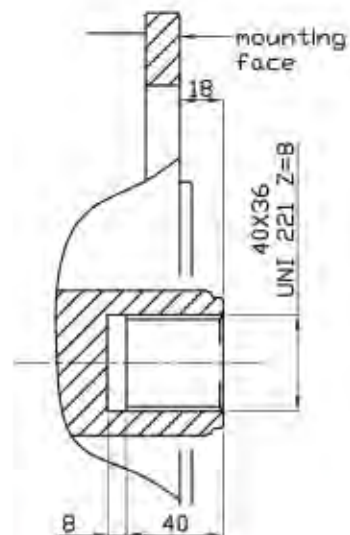
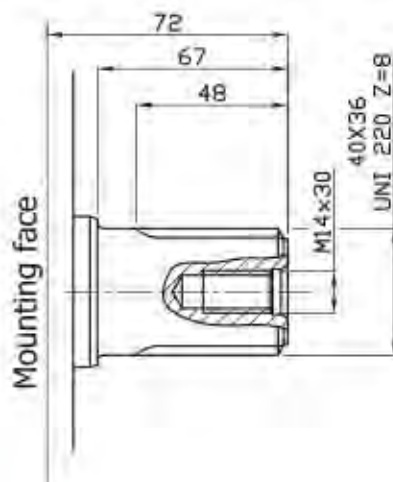

## ORDERING INSTRUCTIONS

	<b>IAM</b>	<b>- - -</b>	<b>- - -</b>	<b>H3</b>	<b>A -</b>	<b>D - -</b>	<b>- - -</b>	<b>SB -</b>
Motor model	IAM							
Displacement								
Interchangeability								
	<b>/C</b> (450/C)							
	<b>/B30</b> (450/B30)							
	<b>/N</b>							
	<b>/GM3</b> <b>/S</b>							
Housing								
Shaft								
	<b>A0</b> standard splined shaft							
	<b>A1</b> special splined shaft							
	<b>A2</b> parallel keyed shaft							
	<b>A3</b> special female shaft							
	<b>A..</b> other shaft							
Distributor								
	<b>D31</b> (3/4" BSP)							
	<b>D310</b> (1" BSP)							
	<b>D40</b> (1" BSP)							
	<b>D47</b> SAE CONFIGURATIONS							
Tachometer								
	<b>TA</b>							
	<b>TB</b>							
	<b>EST</b>							
	<b>EST.30</b>							
	<b>J</b> TACHOMETER PREDISPOSITION							
Spline billet								
	<b>SB3</b> 36x42 UNI 221							
	<b>SB4</b> 46x50 UNI 220							
	<b>SB5</b> 46x54 UNI 221							

**EXAMPLE:** IAM.400.H3.A0.D40  
IAM.450/C.H3.A1.D40.J.SB5  
IAM.500/GM3.H3.A0.D40.TA.SB5

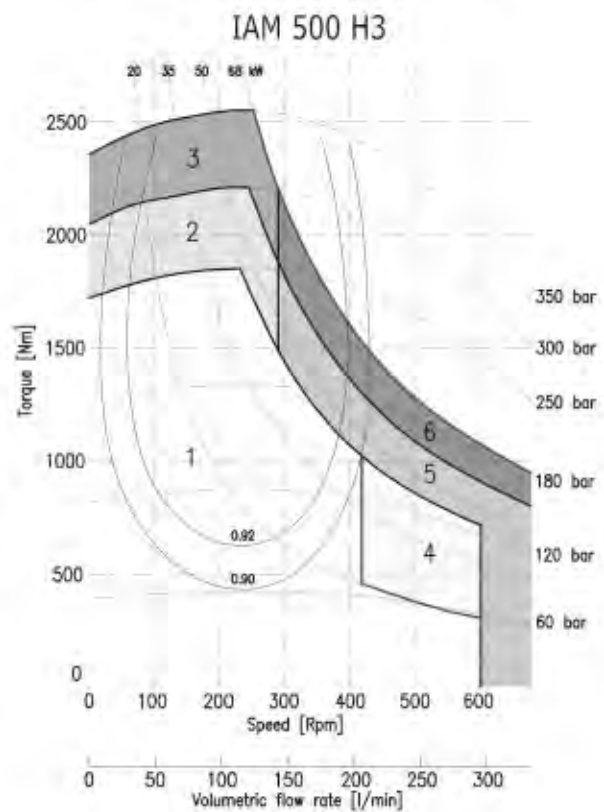
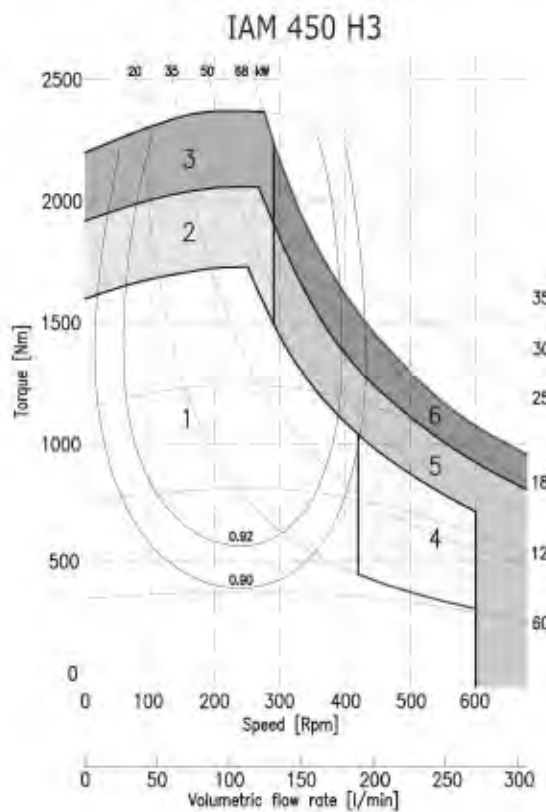
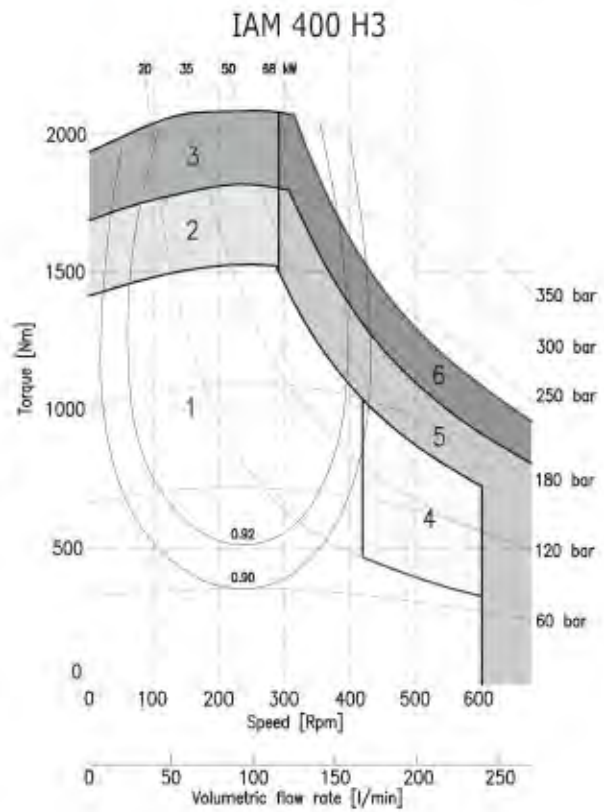
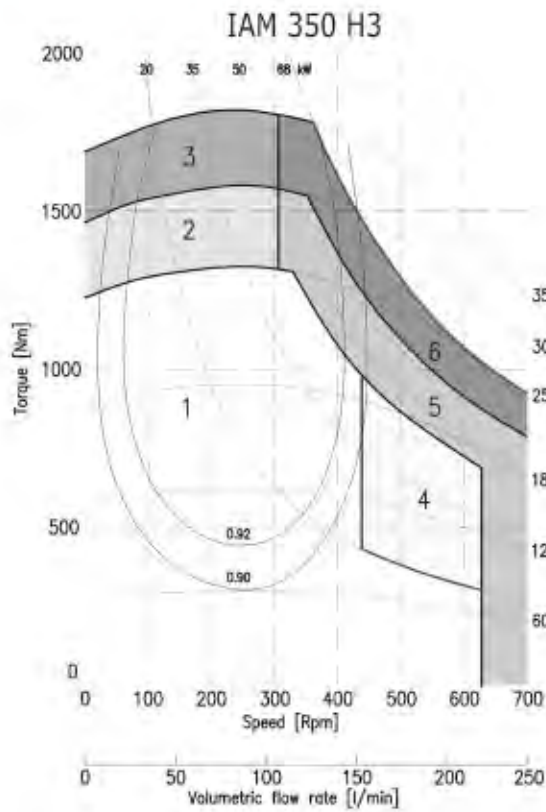

- 1 Continuous operation
- 2 Intermittent operation for period 3-5 minutes every 10-15 minutes
- 3 Intermittent operation for very short period (3-5 seconds every 10-15 minutes)

- 4 Continuous operation with flushing
- 5 Intermittent operation for period 3-5 minutes every 10-15 minutes with flushing
- 6 Intermittent operation for very short period (3-5 seconds every 10-15 minutes) with flushing



### IAM 600 H3

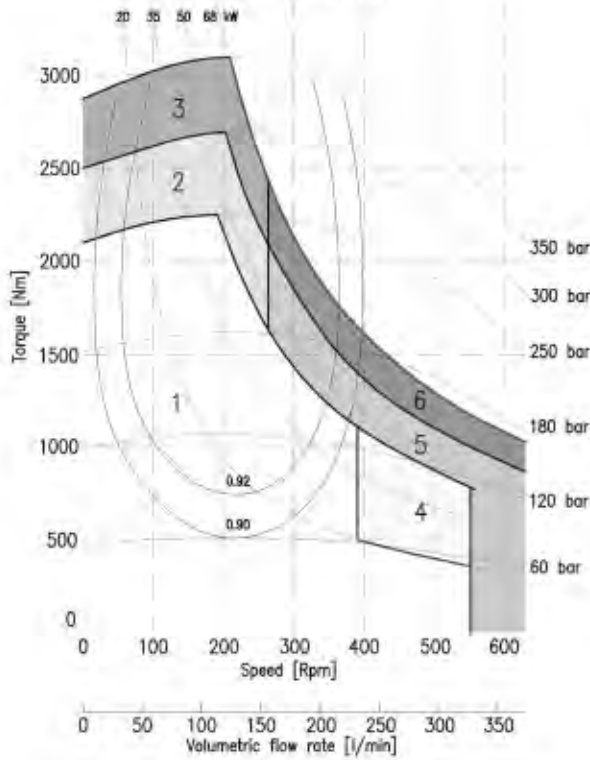

### IAM 650 H3

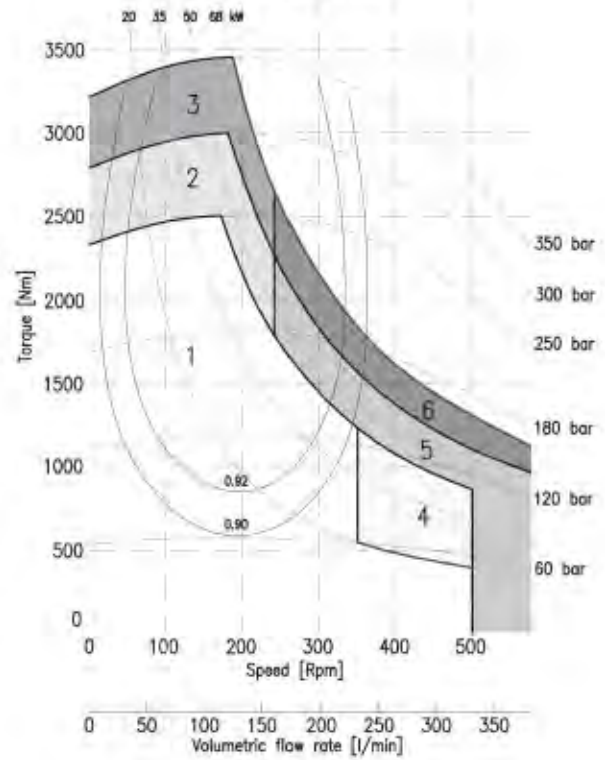

### IAM 700 H3

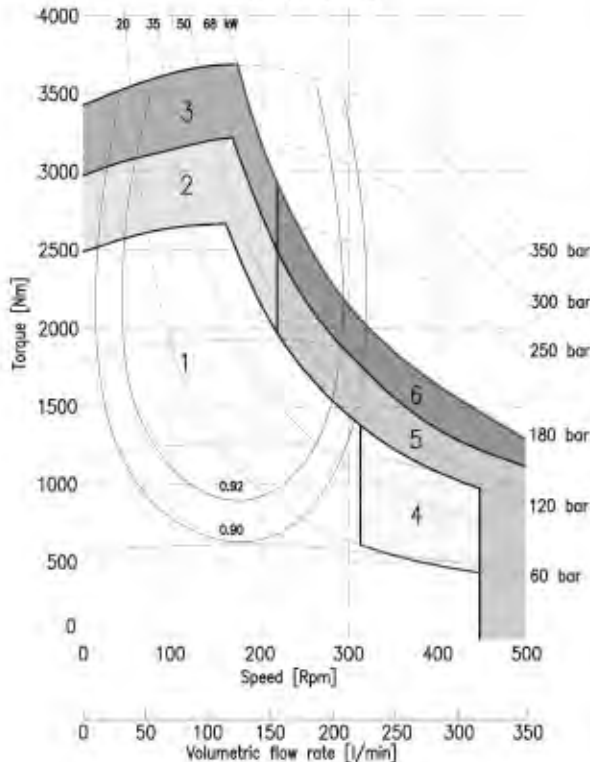

### IAM 800 H3

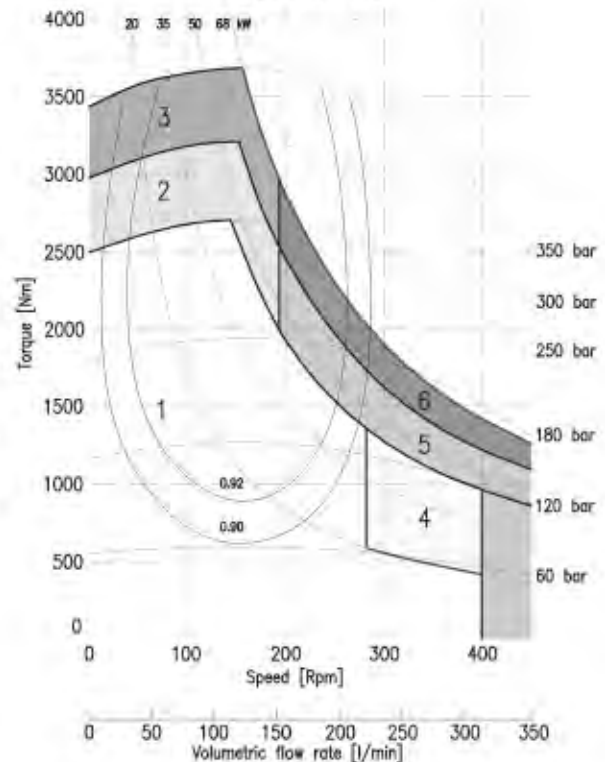

1	Continuous operation
2	Intermittent operation for period 3-5 minutes every 10-15 minutes
3	Intermittent operation for very short period (3-5 seconds every 10-15 minutes)

4	Continuous operation with flushing
5	Intermittent operation for period 3-5 minutes every 10-15 minutes with flushing
6	Intermittent operation for very short period (3-5 seconds every 10-15 minutes) with flushing

---

# ***ITALGROUP - ADVANCED - MOTORS***

## ***IAM SERIES***

### ***H4 MODEL***

---

***IAM 700-800-850-900  
1000-1100-1200  
1250-1400 H4***

***IAM 700/C-800/C H4***

***IAM 800/B45 H4***

***IAM 700-800-900  
1000-1100-1250/S H4***

***IAM 700-800-900  
1000-1100-1250/GM4 H4***

---

## ***INDEX***

TECHNICAL DATA - - - - -	<i>Pag.</i>	54
IAM H4 700-800-850-900-1000-1100-1200-1250-1400 - - - - -	"	55
IAM H4 700/C-800/C - - - - -	"	56
IAM H4 800/B45 - - - - -	"	57
IAM H4 700-800-900-1000-1100-1250/S - - - - -	"	58
IAM H4 700-800-900-1000-1100-1250/GM4 - - - - -	"	59
ORDERING INSTRUCTIONS - - - - -	"	60
GRAPHIC PERFORMANCES H4 700-800-850-900 - - - - -	"	61
GRAPHIC PERFORMANCES H4 1000-1100-1200-1250 - - - - -	"	62
GRAPHIC PERFORMANCES H4 1400 - - - - -	"	63

---

MODEL		IAM 700 H4	IAM 800 H4	IAM 850 H4	IAM 900 H4	IAM 1000 H4	IAM 1100 H4	IAM 1200 H4	IAM 1250 H4	IAM 1400 H4
Displacement	cc/rev	714	792	847	904	992	1116	1192	1247	1332
Specific Torque	Nm/bar	11.4	12.6	13.5	14.4	15.8	17.8	19.0	19.8	21.2
Max cont. Pressure	bar	250	250	250	250	250	250	250	250	250
Max int. Pressure	bar	300	300	300	300	300	300	300	300	300
Peak pressure	bar	350	350	350	350	350	350	350	350	350
Max continuous speed	rpm	500	450	450	450	330	330	300	250	200
Peak speed	rpm	580	530	530	530	400	400	350	300	250
Max continuous power	HP	75	75	75	75	75	75	75	75	75
	KW	55	55	55	55	55	55	55	55	55
Max power	HP	107	107	107	107	107	107	107	107	107
	KW	80	80	80	80	80	80	80	80	80

- N° of pistons: 5
- Max case pressure: 6 bar
- Max back pressure: 70 bar
- Dry weight: 92 kg
- Temperature range: -30°C ÷ +70°C
- Minimum speed: 1 rpm
- Flushing flow<sup>(\*)</sup>:
 

IAM H4 700 – 800 – 850 – 900	10 l/min
IAM H4 1000 – 1100 – 1200 – 1250	10 l/min

(\*)for further details regarding flushing go to page 10 of this catalogue.



## SIZE

IAM 700-800-850-900-1000-1100-1200-1250-1400 H4

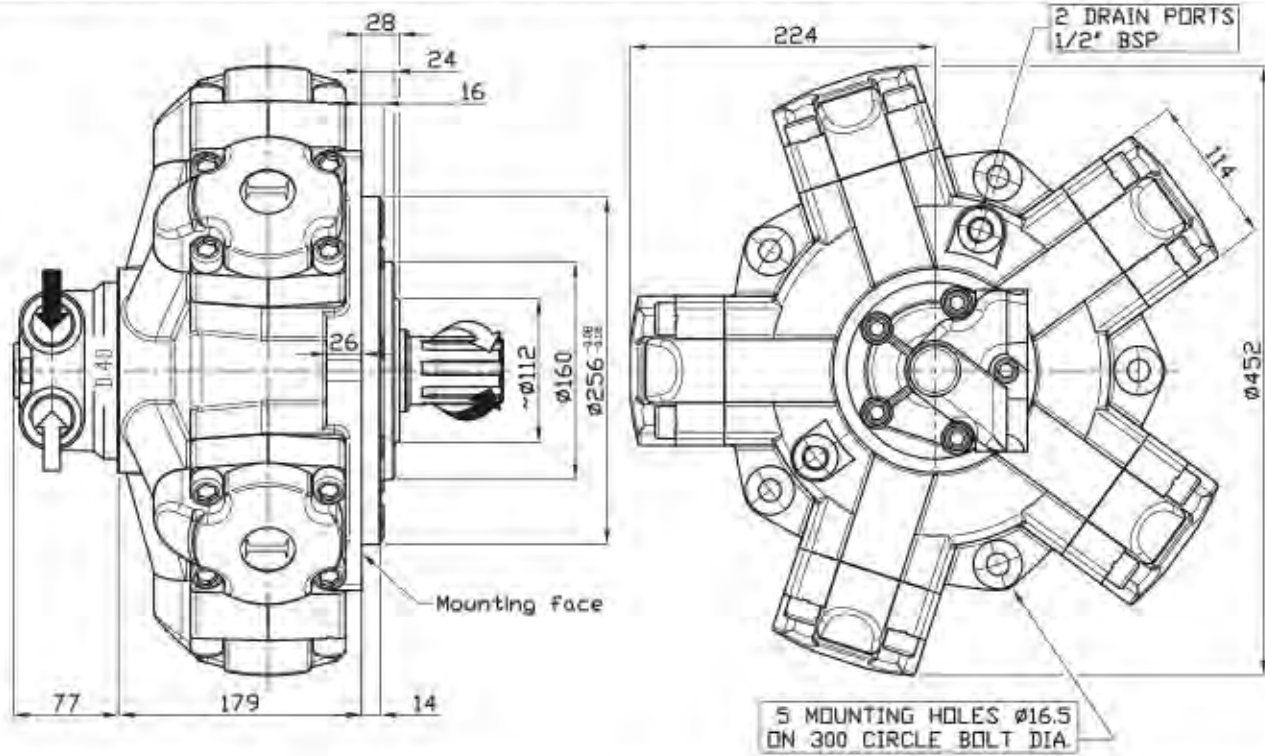

## SHAFT

IAM 700-800-850-900-1000-1100-1200-1250-1400 H4

A0: Standard splined shaft

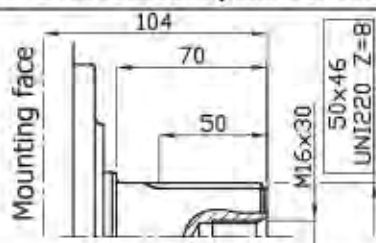

A1: Splined shaft on request

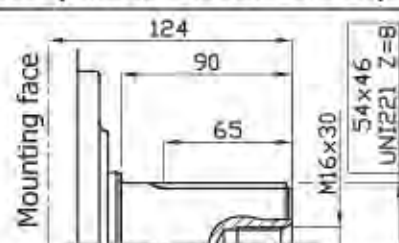

A2: Parallel shaft on request

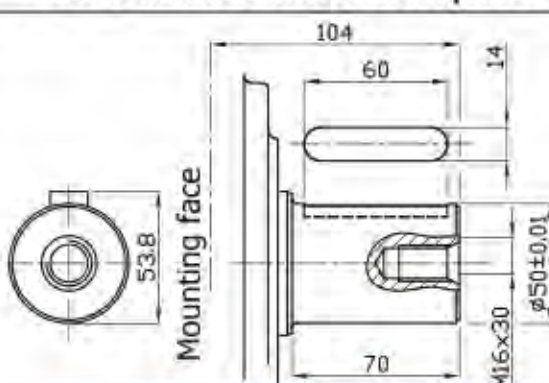

A3: Female shaft on request

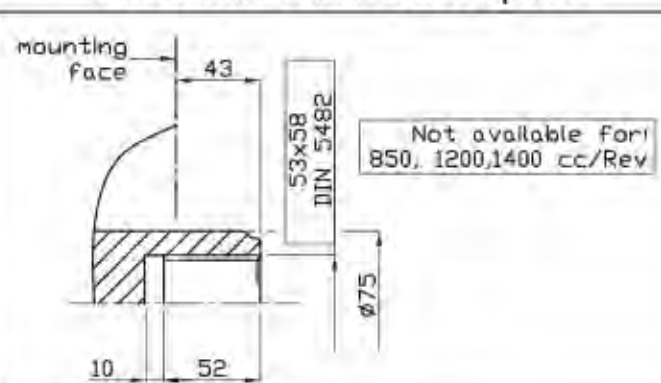

## SIZE

### IAM 700/C-800/C H4

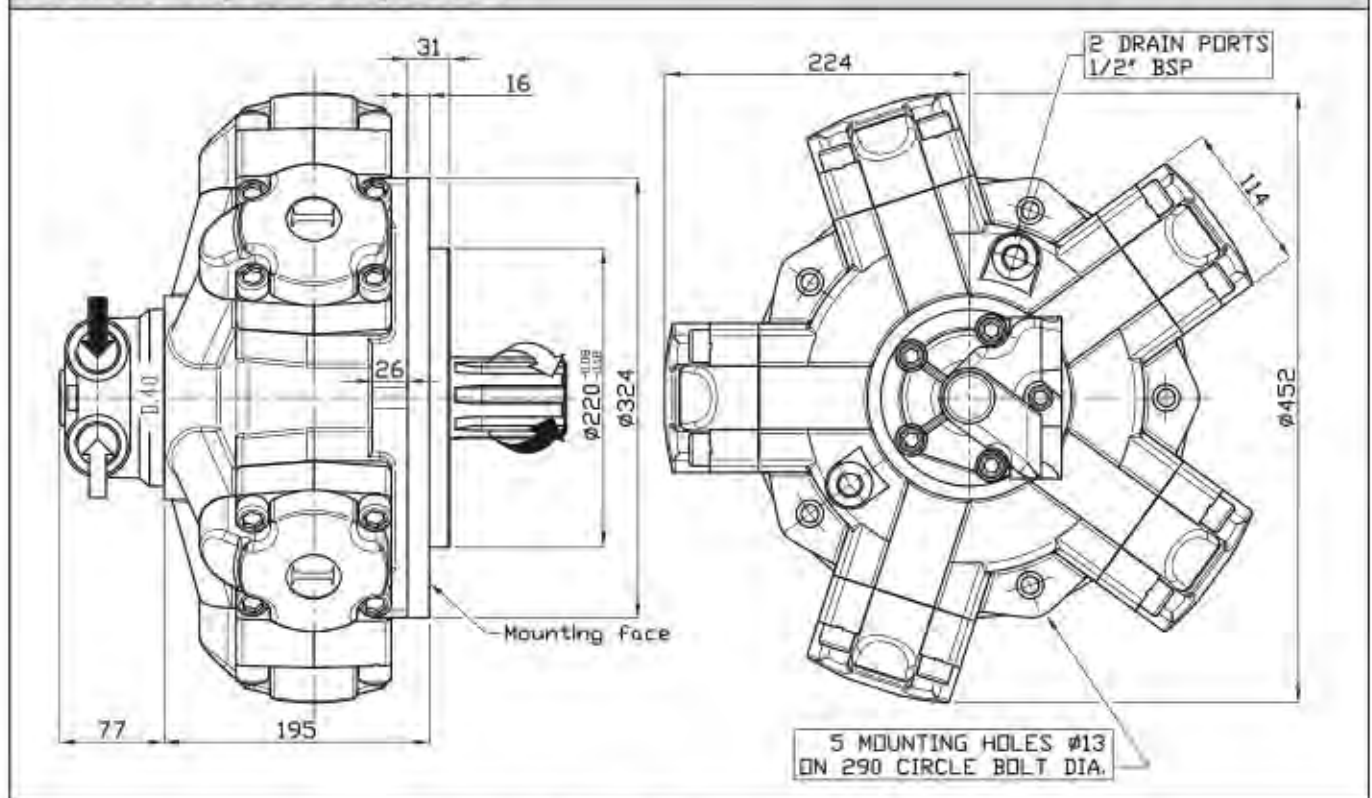

## SHAFT & OPTION

### IAM 700/C-800/C H4

A0: Standard splined shaft

FL2: connection block

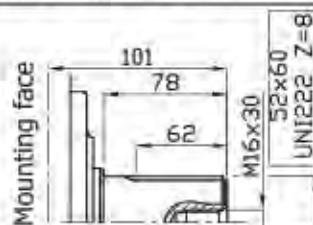

Connection block, fitting D47 distributor, for motor MR 350/450/500/600/700/800

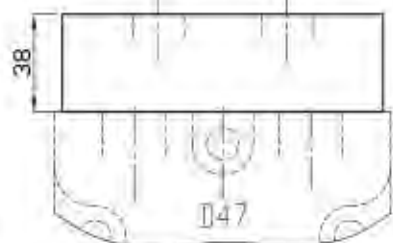

A2: Parallel shaft  
on request

A3: Female shaft  
on request

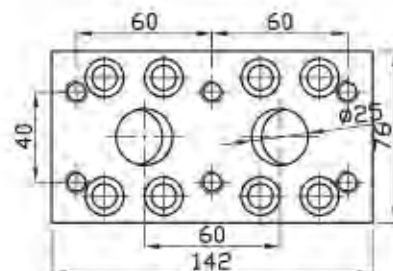
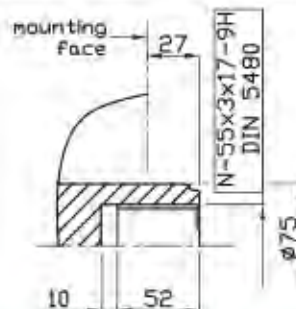
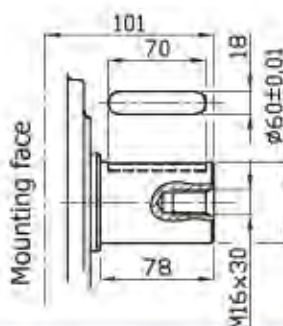



## SIZE

### IAM 800/B45 H4

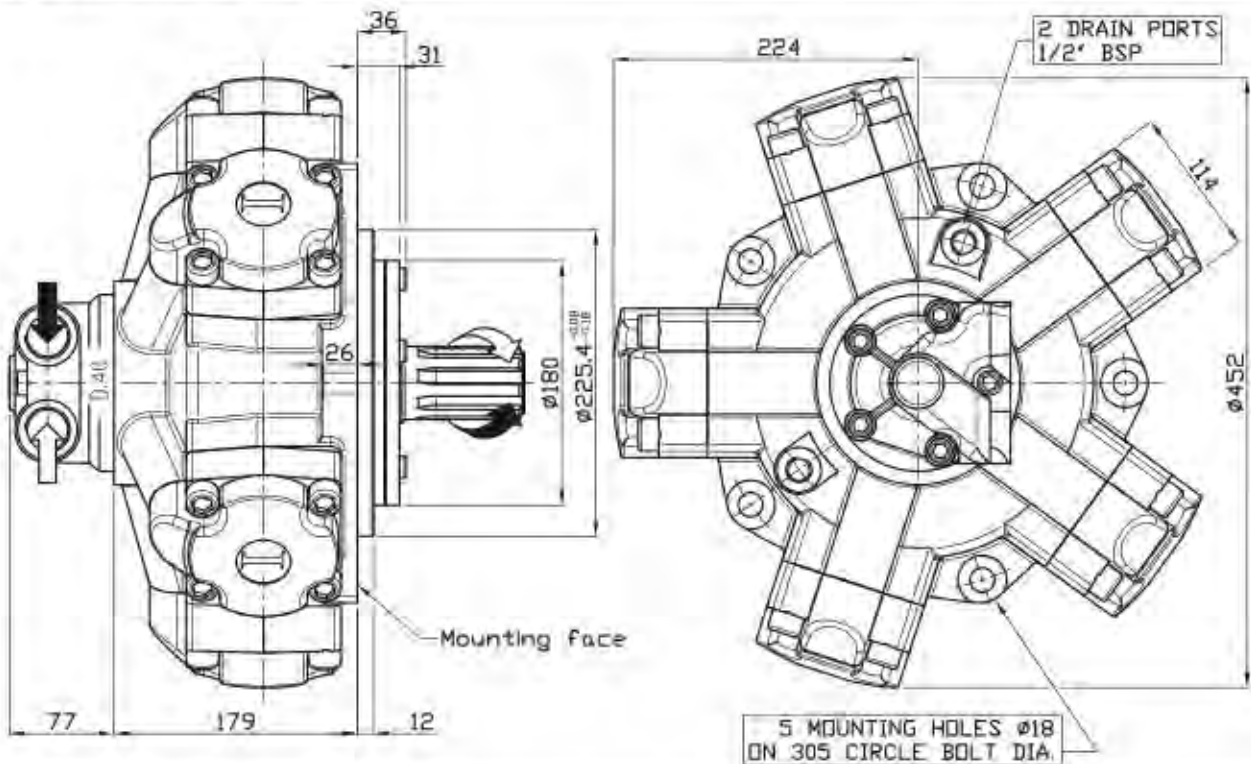

## SHAFT

### IAM 800/B45 H4

A0: Standard splined shaft

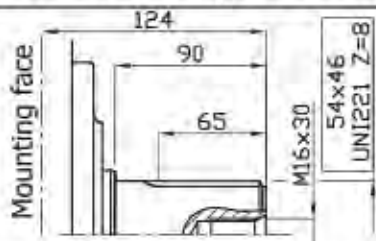

A1: Splined shaft on request

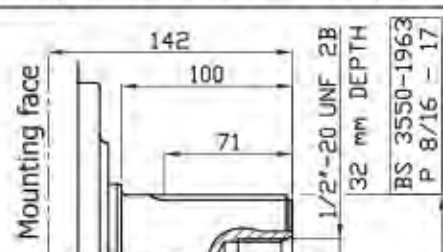

A2: Parallel shaft on request

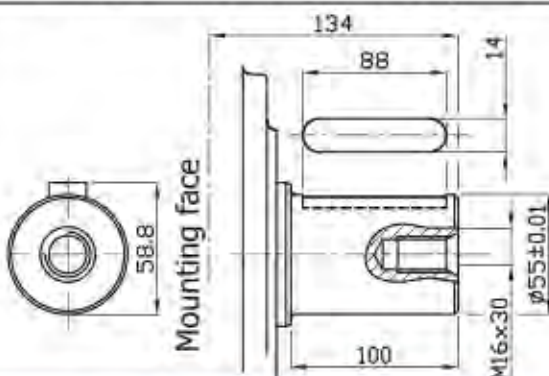

A4: Splined shaft on request

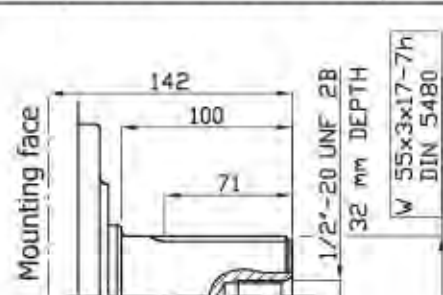



## SIZE

IAM 700/S 800/S 900/S 1000/S 1100/S 1250/S H4

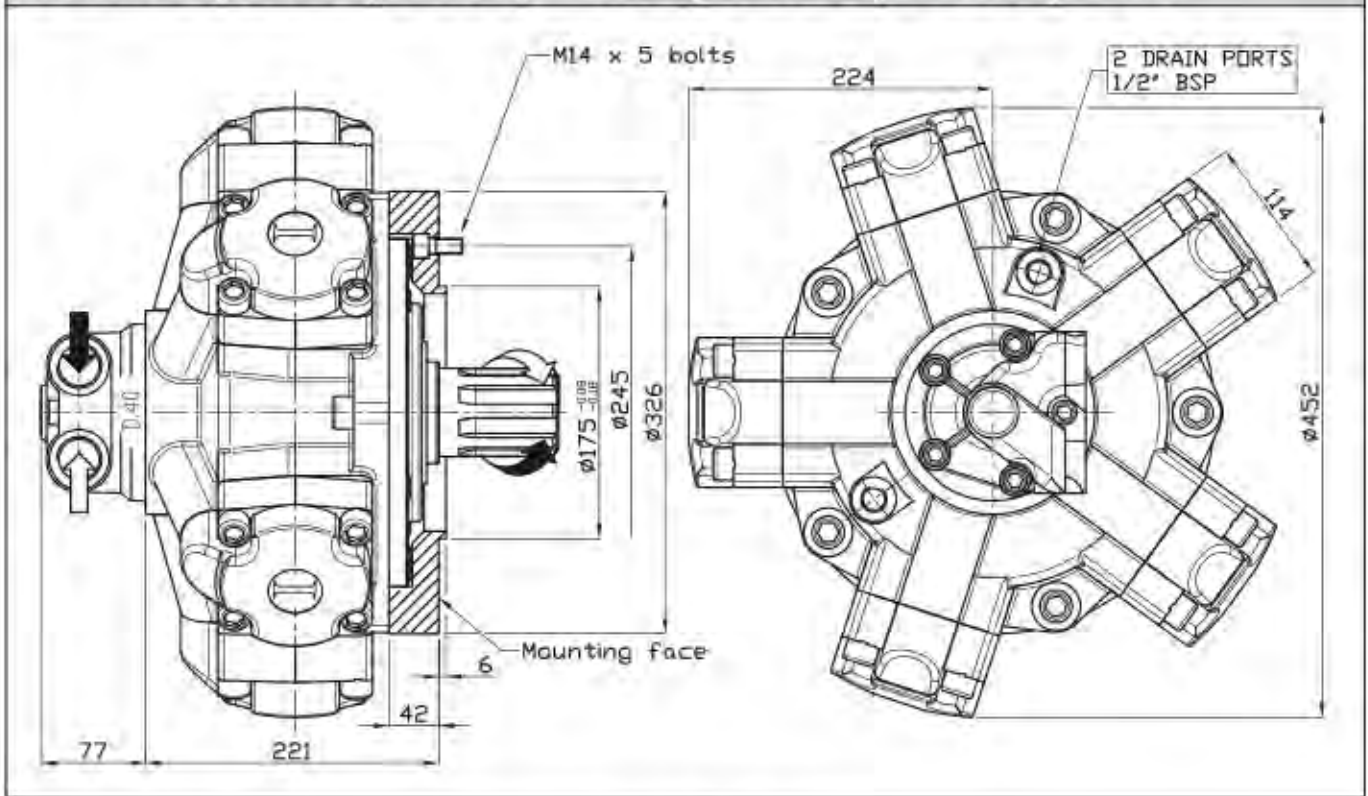

## SHAFT

IAM 700/S 800/S 900/S 1000/S 1100/S 1250/S H4

A0: Standard splined shaft

A3: Female shaft on request

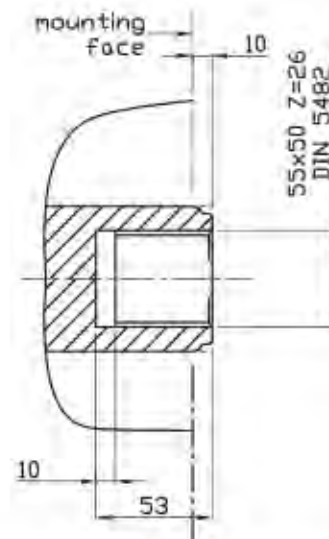
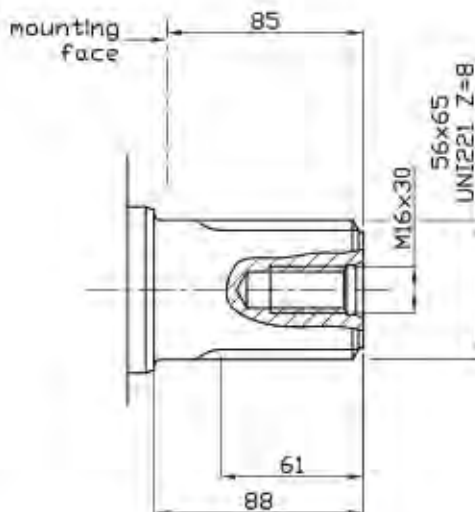

## SIZE

IAM 700/GM4 800/GM4 900/GM4 1000/GM4 1100/GM4 1250/GM4 H4

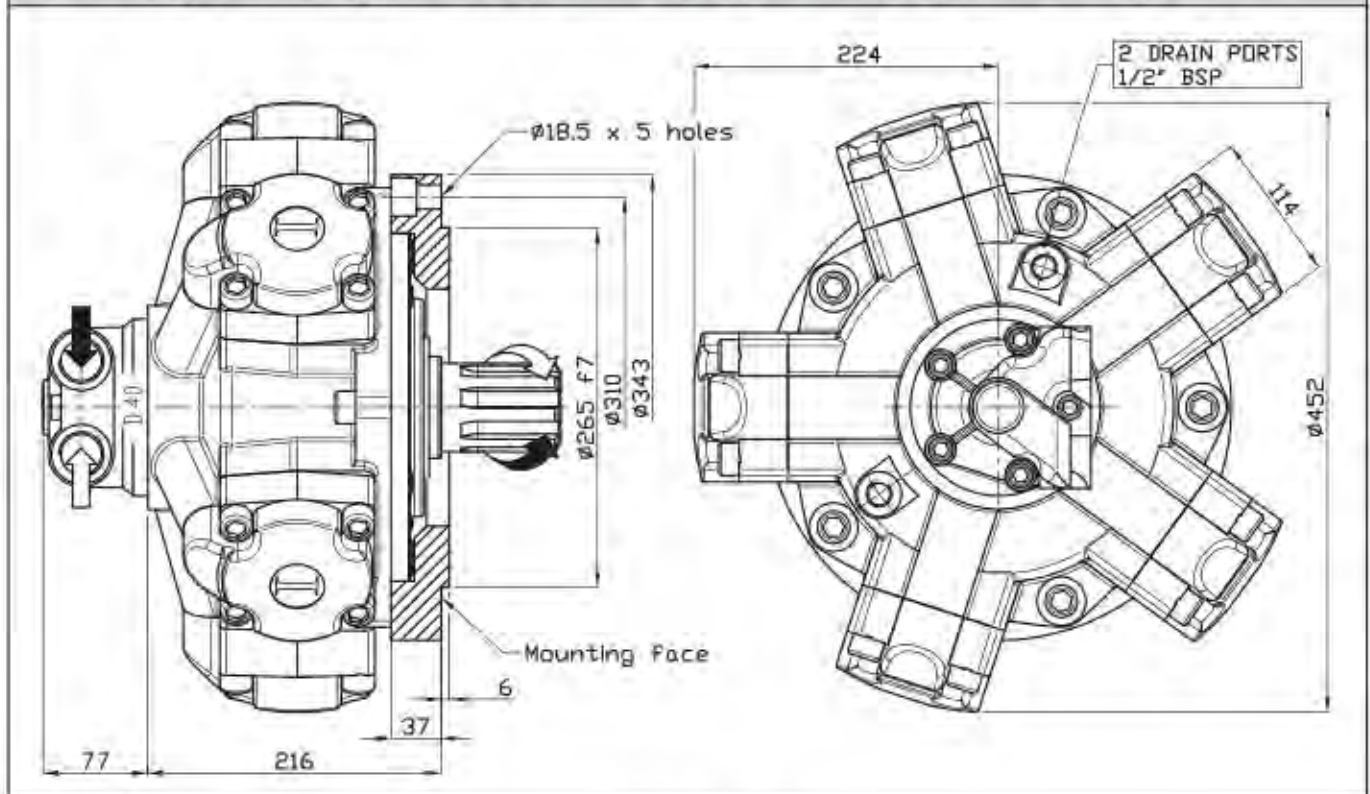

## SHAFT

IAM 700/GM4 800/GM4 900/GM4 1000/GM4 1100/GM4 1250/GM4 H4

A0: Standard splined shaft

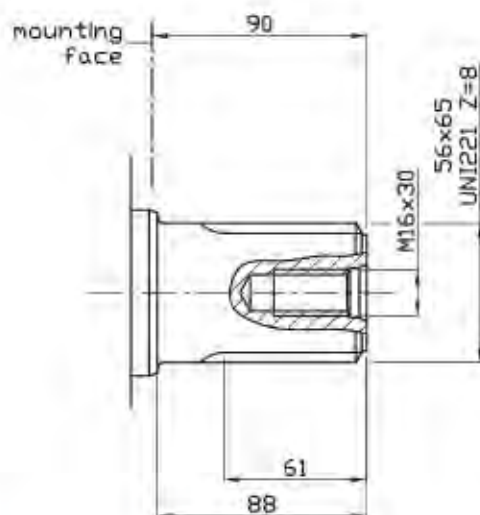



## ORDERING INSTRUCTIONS

	<b>IAM</b>	<b>- - -</b>	<b>- - -</b>	<b>H4</b>	<b>A -</b>	<b>D - -</b>	<b>- - -</b>	<b>SB -</b>
Motor model	IAM							
Displacement								
Interchangeability								
	<b>/C</b> (700/C, 800/C)							
	<b>/B45</b> (800/B45)							
	<b>/GM4</b> <b>/S</b>							
Housing								
Shaft								
	<b>A0</b> standard splined shaft							
	<b>A1</b> special splined shaft							
	<b>A2</b> parallel keyed shaft							
	<b>A3</b> special female shaft							
	<b>A..</b> other shaft							
Distributor								
	<b>D31</b> (3/4" BSP)							
	<b>D310</b> (1" BSP)							
	<b>D40</b> (1" BSP)							
	<b>D47</b> SAE CONFIGURATIONS							
Tachometer								
	<b>TA</b>							
	<b>TB</b>							
	<b>EST</b>							
	<b>EST.30</b>							
	<b>J</b> TACHOMETER PREDISPOSITION							
Spline billet								
	<b>SB4</b> 46x50 UNI 220							
	<b>SB5</b> 46x54 UNI 221							
	<b>SB16</b> 52x60 UNI 222							

**EXAMPLE:** IAM.700.H4.A1.D40.SB5  
 IAM.800/B45.H4.A1.D31.TA  
 IAM.700/C.H4.A0.D40.J.SB16

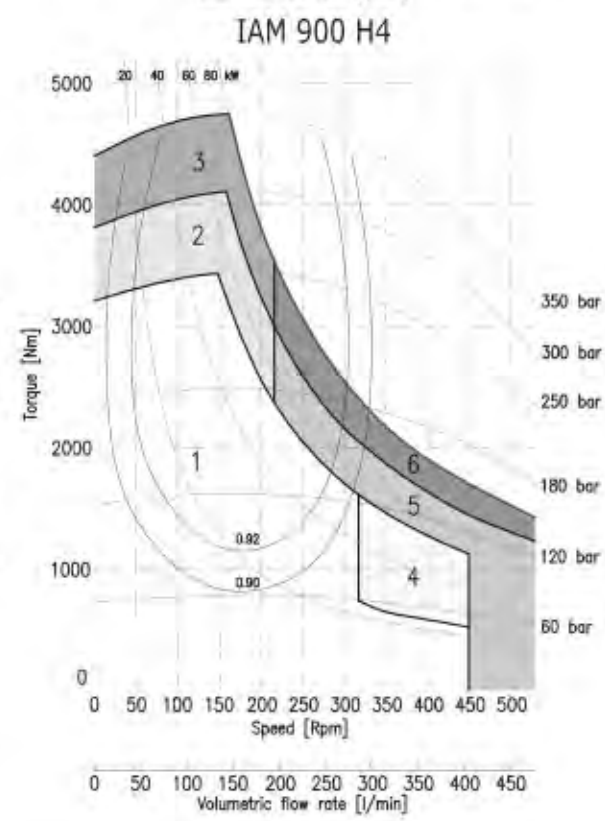
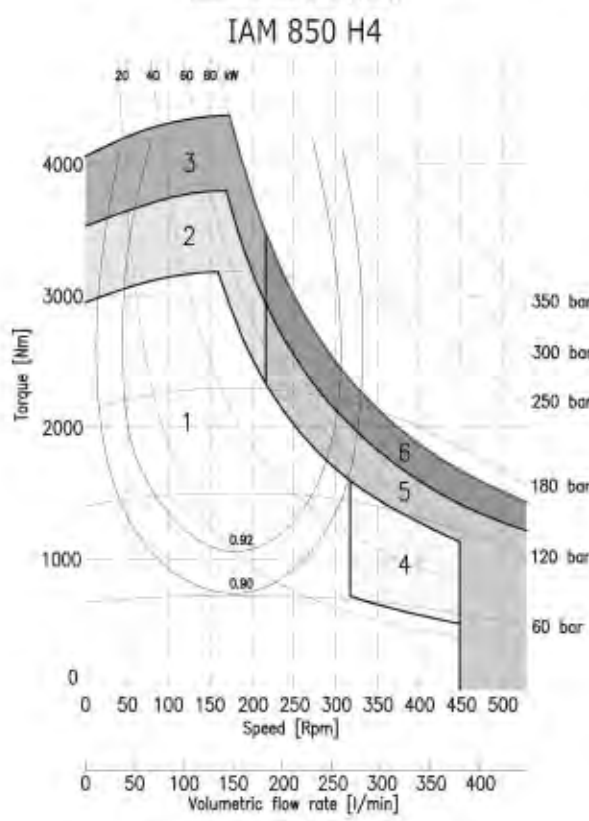
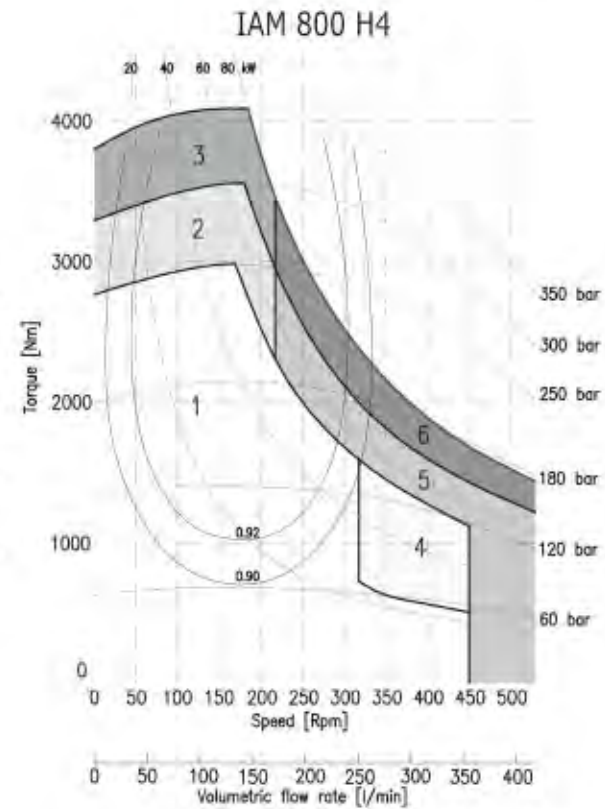
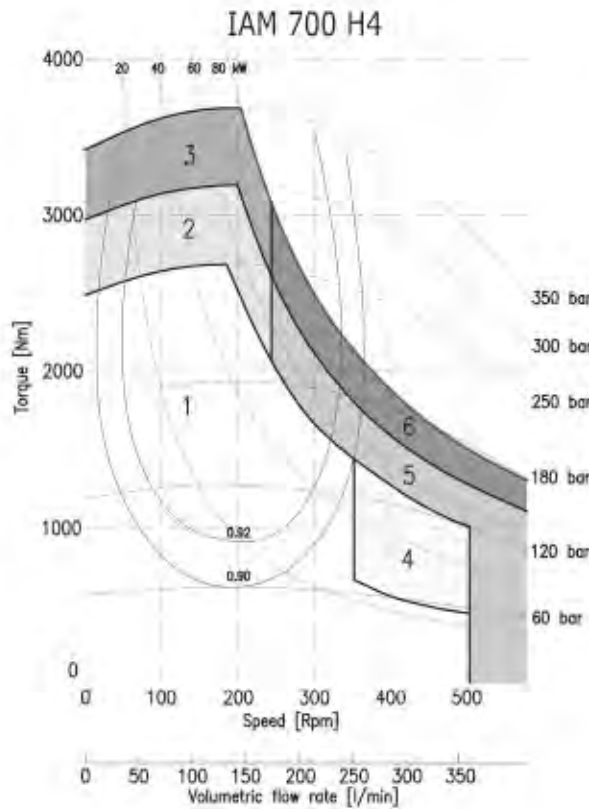

- 1 Continuous operation
- 2 Intermittent operation for period 3-5 minutes every 10-15 minutes
- 3 Intermittent operation for very short period (3-5 seconds every 10-15 minutes)

- 4 Continuous operation with flushing
- 5 Intermittent operation for period 3-5 minutes every 10-15 minutes with flushing
- 6 Intermittent operation for very short period (3-5 seconds every 10-15 minutes) with flushing



### IAM 1000 H4

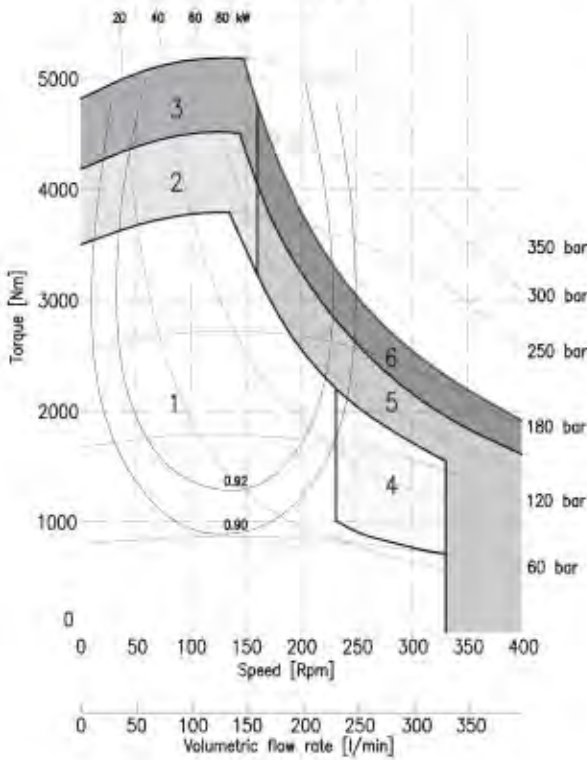

### IAM 1100 H4

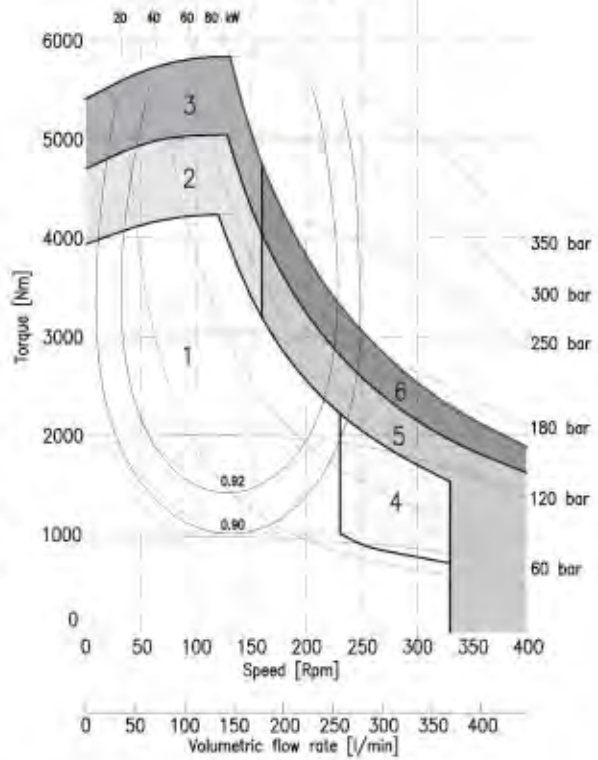

### IAM 1200 H4

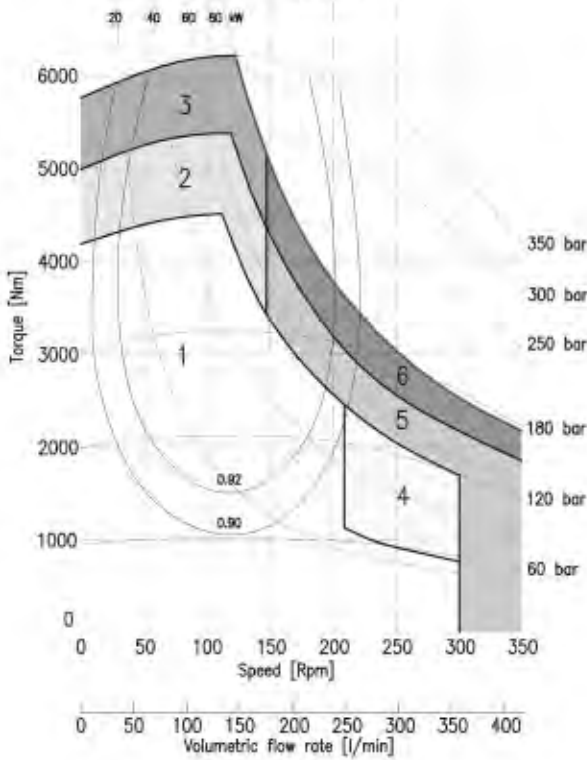

### IAM 1250 H4

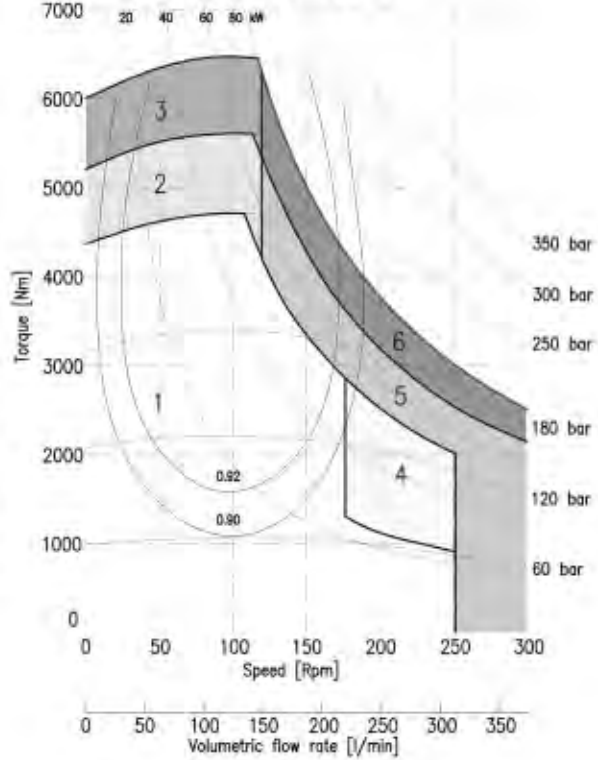

- 1 Continuous operation
- 2 Intermittent operation for period 3-5 minutes every 10-15 minutes
- 3 Intermittent operation for very short period (1-5 seconds every 10-15 minutes)

- 4 Continuous operation with flushing
- 5 Intermittent operation for period 3-5 minutes every 10-15 minutes with flushing
- 6 Intermittent operation for very short period (3-5 seconds every 10-15 minutes) with flushing

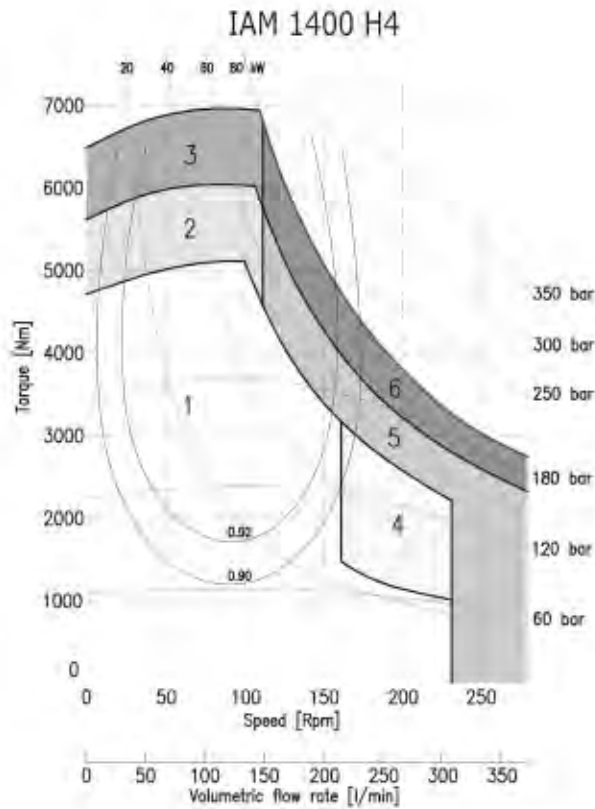

- 1 Continuous operation
- 2 Intermittent operation for period 3-5 minutes every 10-15 minutes
- 3 Intermittent operation for very short period (3-5 seconds) every 10-15 minutes

- 4 Continuous operation with flushing
- 5 Intermittent operation for period 3-5 minutes every 10-15 minutes with flushing
- 6 Intermittent operation for very short period (3-5 seconds) every 10-15 minutes with flushing





---

# ***ITALGROUP - ADVANCED - MOTORS***

---

## ***IAM SERIES***

---

### ***H45 MODEL***

---

***IAM 1100-1400-1600  
1800 H45***

***IAM 1100-1400/C H45***

---

### ***INDEX***

---

TECHNICAL DATA -----	<i>Pag.</i>	66
IAM H45 1100-1400-1600-1800 -----	"	67
IAM H45 1100-1400/C -----	"	68
ORDERING INSTRUCTIONS -----	"	69
GRAPHIC PERFORMANCES H45 1100-1400-1600-1800 -----	"	70

## TECHNICAL DATA *H45*

	MODEL	IAM 1100 H45	IAM 1400 H45	IAM 1600 H45	IAM 1800 H45
Displacement	cc/rev	1183	1376	1648	1815
Specific Torque	Nm/bar	18.8	21.9	26.2	28.9
Max cont. Pressure	bar	250	250	250	250
Max int. Pressure	bar	300	300	300	300
Peak pressure	bar	350	350	350	350
Max continuous speed	rpm	350	300	275	250
Peak speed	rpm	400	350	325	300
Max continuous power	HP	116	116	116	116
	kW	85	85	85	85
Max power	HP	161	161	161	161
	kW	120	120	120	120

- N° of pistons: 5
- Max case pressure: 6 bar
- Max back pressure: 70 bar
- Dry weight: 118 kg
- Temperature range: -30°C ÷ +70°C
- Minimum speed: 0.5 rpm
- Flushing flow: 10 l/min

(\*)for further details regarding flushing go to page 10 of this catalogue.

## SIZE

### IAM H45 1100-1400-1600-1800

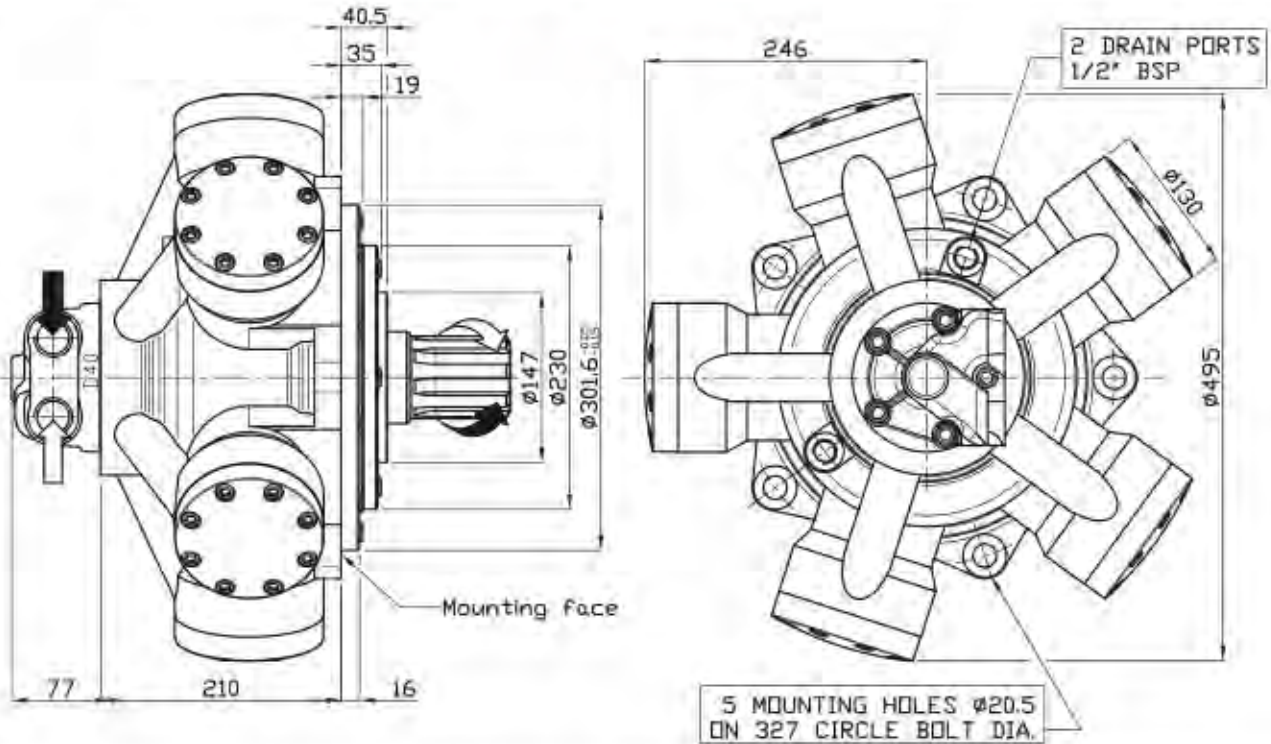

## SHAFT

### IAM H45 1100-1400-1600-1800

A0: Standard splined shaft

A1: Splined shaft on request

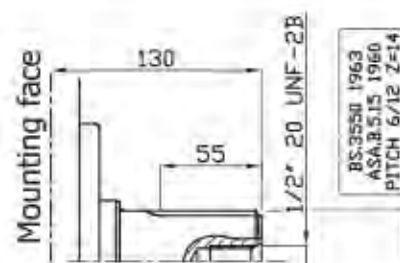
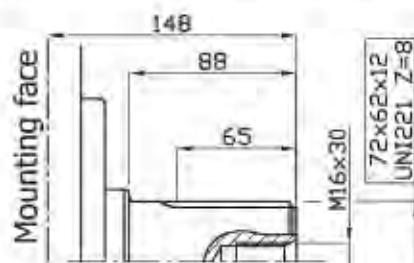





# ORDERING INSTRUCTIONS

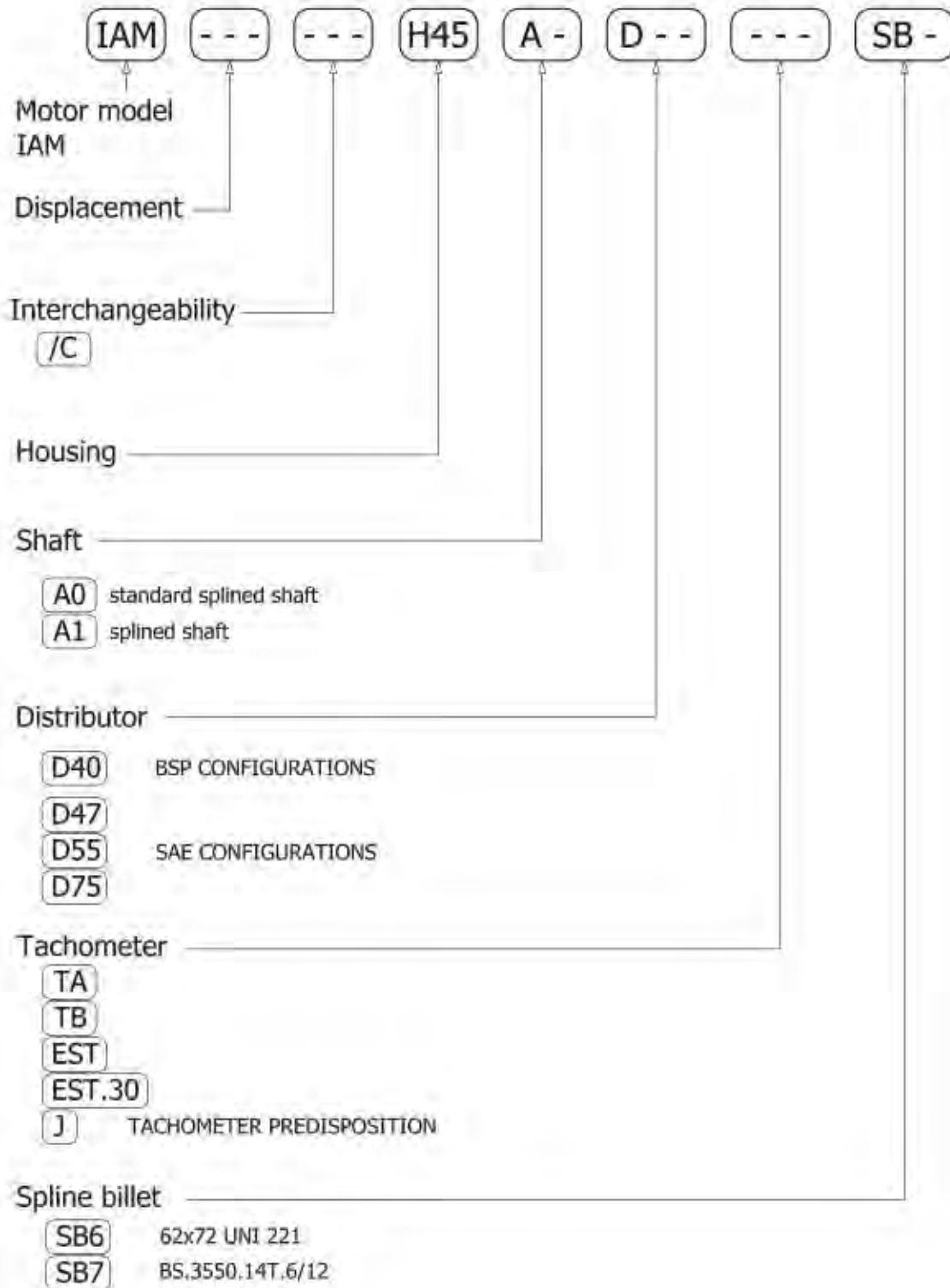

**EXAMPLE:** IAM.1100/C.H45.A0.D40  
 IAM.1400.H45.A1.D55.TA.SB6  
 IAM.1600.H45.A0.D40

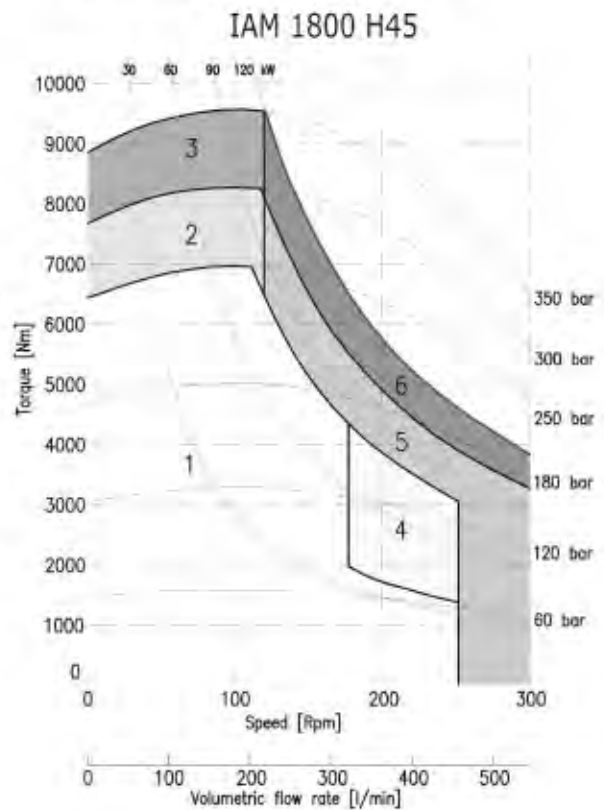
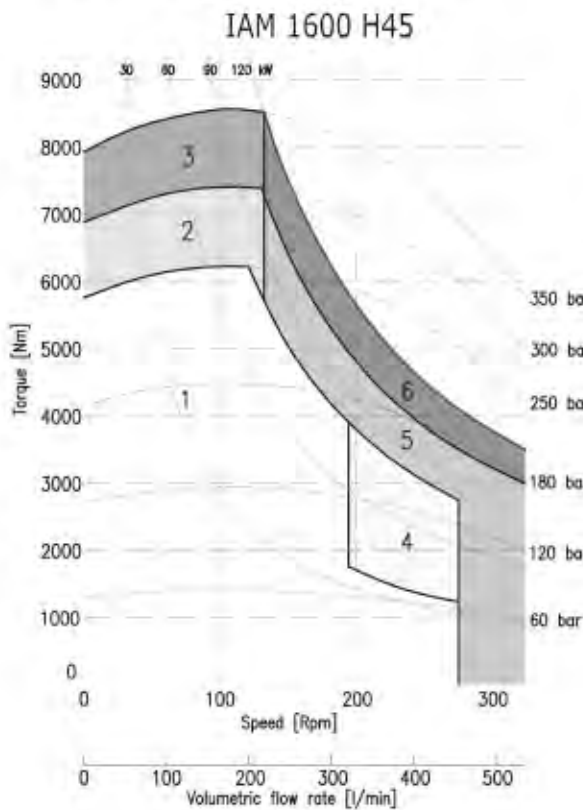
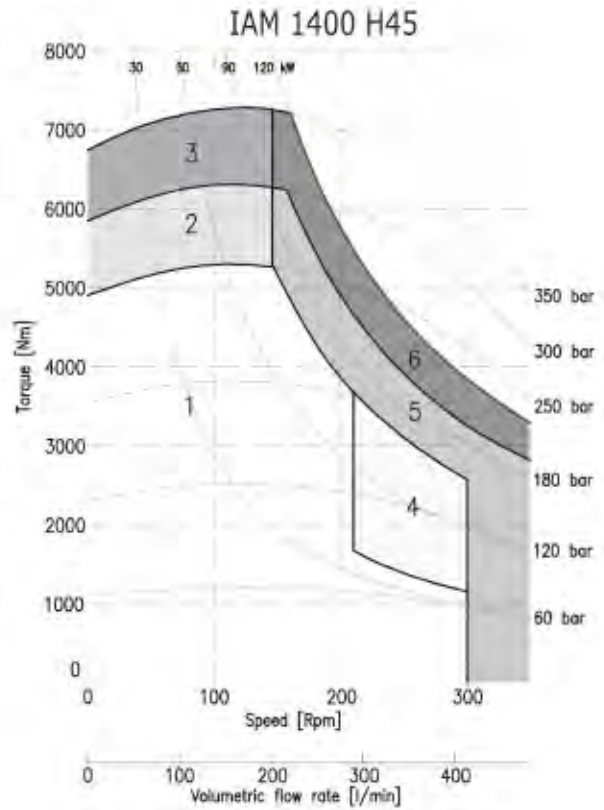
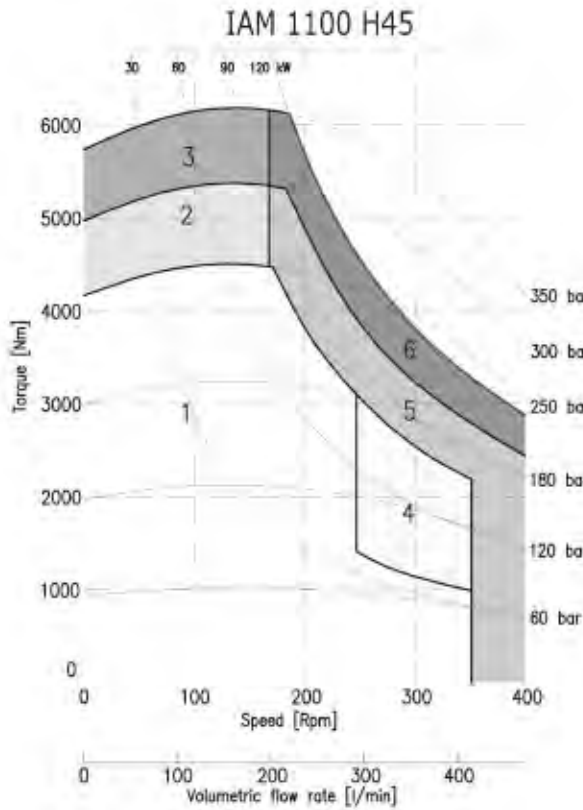

- 1 Continuous operation
- 2 Intermittent operation for period 3-5 minutes every 10-15 minutes
- 3 Intermittent operation for very short period (3-5 seconds every 10-15 minutes)

- 4 Continuous operation with flushing
- 5 Intermittent operation for period 3-5 minutes every 10-15 minutes with flushing
- 6 Intermittent operation for very short period (3-5 seconds every 10-15 minutes) with flushing



---

**ITALGROUP - ADVANCED - MOTORS****IAM SERIES****H5 MODEL**

---

**IAM 1000-1200-1400  
1500-1600-1800  
2000-2200 H5**

**IAM 1200-1400-1500/C H5**

**IAM 1600-1800-2000  
2200/C H5**

**IAM 1000/B60 - 1400/B80  
1600/B100 H5**

**IAM 1000-1200-1400  
1500-1600-1800  
2000-2200 H5**

---

**INDEX**

TECHNICAL DATA -----	Pag.	72
IAM H5 1000-1200-1400-1500-1600-1800-2000-2200 -----	"	73
IAM H5 1200-1400-1500/C -----	"	74
IAM H5 1600-1800-2000-2200/C -----	"	75
IAM H5 1000/B60-1400/B80-1600/B100 -----	"	76
IAM H5 1000-1200-1400-1500-1600-1800-2000-2200/GM5 (S) -----	"	77
ORDERING INSTRUCTIONS -----	"	78
GRAPHIC PERFORMANCES H5 1000-1200-1400-1500 -----	"	79
GRAPHIC PERFORMANCES H5 1600-1800-2000-2200 -----	"	80

---

MODEL		IAM 1000 H5	IAM 1200 H5	IAM 1400 H5	IAM 1500 H5	IAM 1600 H5	IAM 1800 H5	IAM 2000 H5	IAM 2200 H5
Displacement	cc/rev	1094	1231	1376	1528	1648	1815	2035	2220
Specific Torque	Nm/bar	17.4	19.6	21.9	24.3	26.2	28.9	32.4	35.3
Max cont. Pressure	bar	250	250	250	250	250	250	250	250
Max int. Pressure	bar	300	300	300	300	300	300	300	300
Peak pressure	bar	350	350	350	350	350	350	350	350
Max continuous speed	rpm	350	300	300	300	300	250	230	220
Peak speed	rpm	400	350	350	350	340	300	260	240
Max continuous power	HP	122	122	122	122	122	122	122	122
	kW	90	90	90	90	90	90	90	90
Max power	HP	161	161	161	161	161	161	161	161
	kW	120	120	120	120	120	120	120	120

- N° of pistons: 5
- Max case pressure: 6 bar
- Max back pressure: 70 bar
- Dry weight: 173 kg
- Temperature range: -30°C ÷ +70°C
- Minimum speed: 0.5 rpm
- Flushing flow: 10 l/min

(\*for further details regarding flushing go to page 10 of this catalogue.



## SIZE

IAM 1000-1200-1400-1500-1600-1800-2000-2200 H5

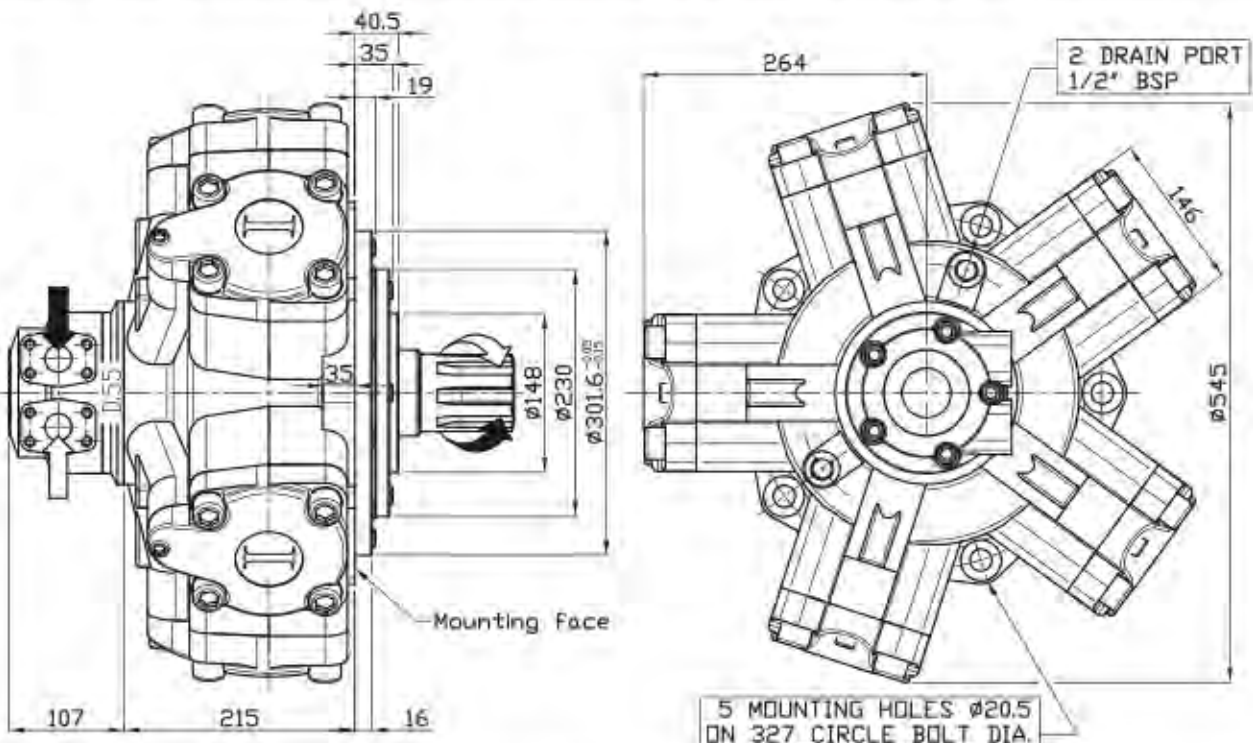

## SHAFT

IAM 1000-1200-1400-1500-1600-1800-2000-2200 H5

A0: Standard splined shaft

A1: Splined shaft on request

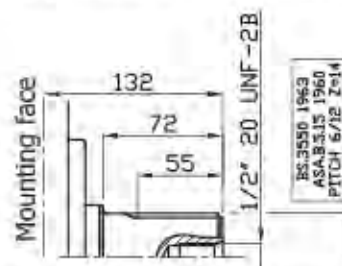
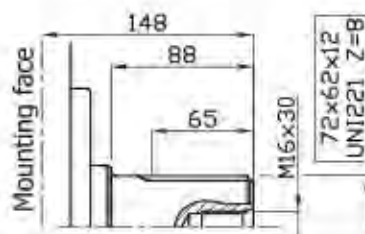

A2: Parallel shaft on request

A3: Female shaft on request

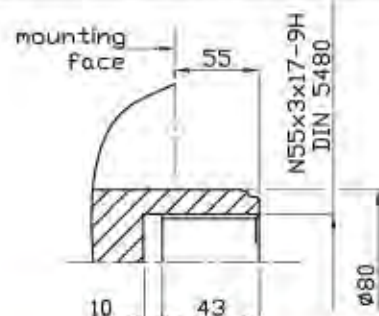
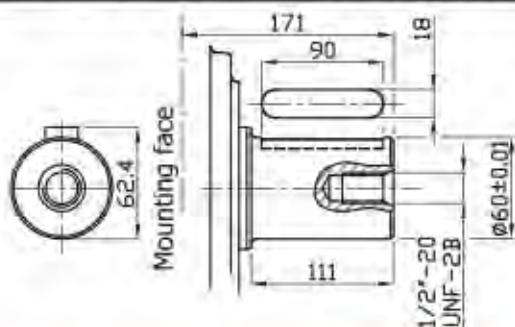



## SIZE

### IAM 1200/C-1400/C-1500/C H5

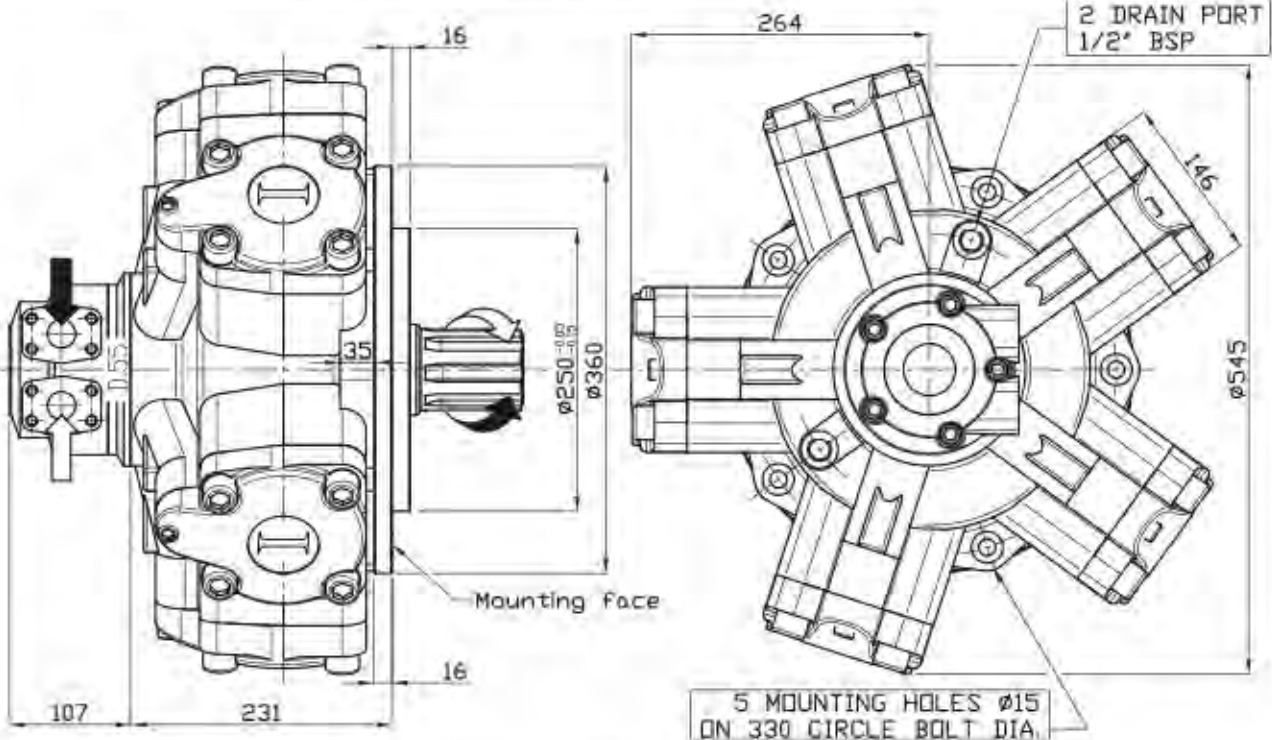

## SHAFT & OPTION

### IAM 1200/C-1400/C-1500/C H5

A0: Standard splined shaft

A1: Splined shaft on request

FL3: connection block

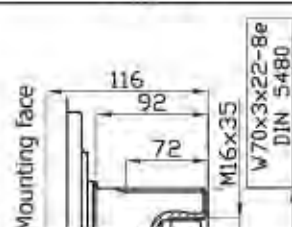
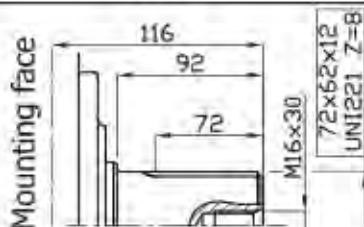

Connection block, fitting D55 distributor, for motor MR 1100/1400/1600/1800/2100

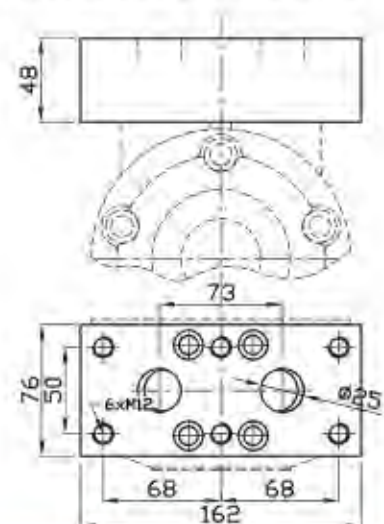

A2: Parallel shaft on request

A3: Female shaft on request

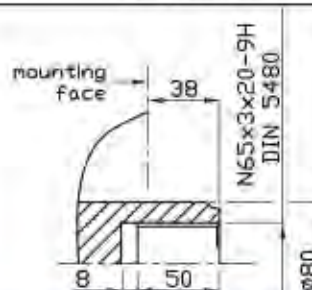
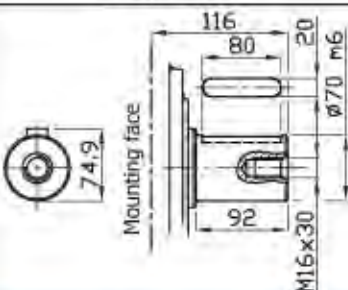





## SIZE

### IAM 1000/B60-1400/B80-1600/B100 H5

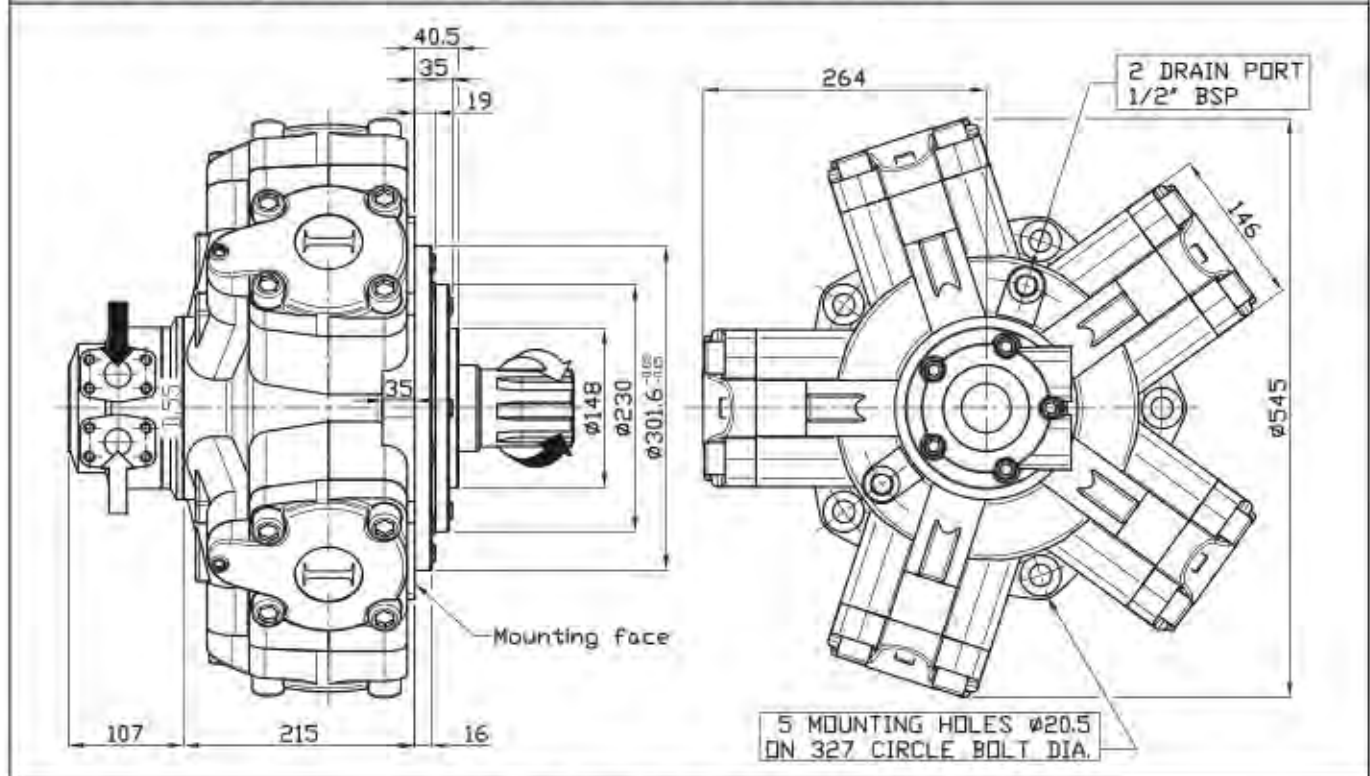

## SHAFT & OPTION

### IAM 1000/B60-1400/B80-1600/B100 H5

A1: Standard splined shaft	FL5: connection block	FL6: connection block
<p>Mounting face</p>	<p>S03 plate for D75 distributor</p>	<p>S04 plate for D75 distributor</p>
<p>A2: Parallel shaft on request</p>	<p>6x3/8"-24 UNF-2B 4xØ12.5 2xØ28</p>	<p>6x3/8"-24 UNF-2B 4xØ12.5 2xØ31.5</p>
<p>Mounting face</p>		



## SIZE

IAM H5 1000/GM5-1200/GM5-1400/GM5-1500/GM5  
1600/GM5-1800/GM5-2000/GM5-2200/GM5 (S)

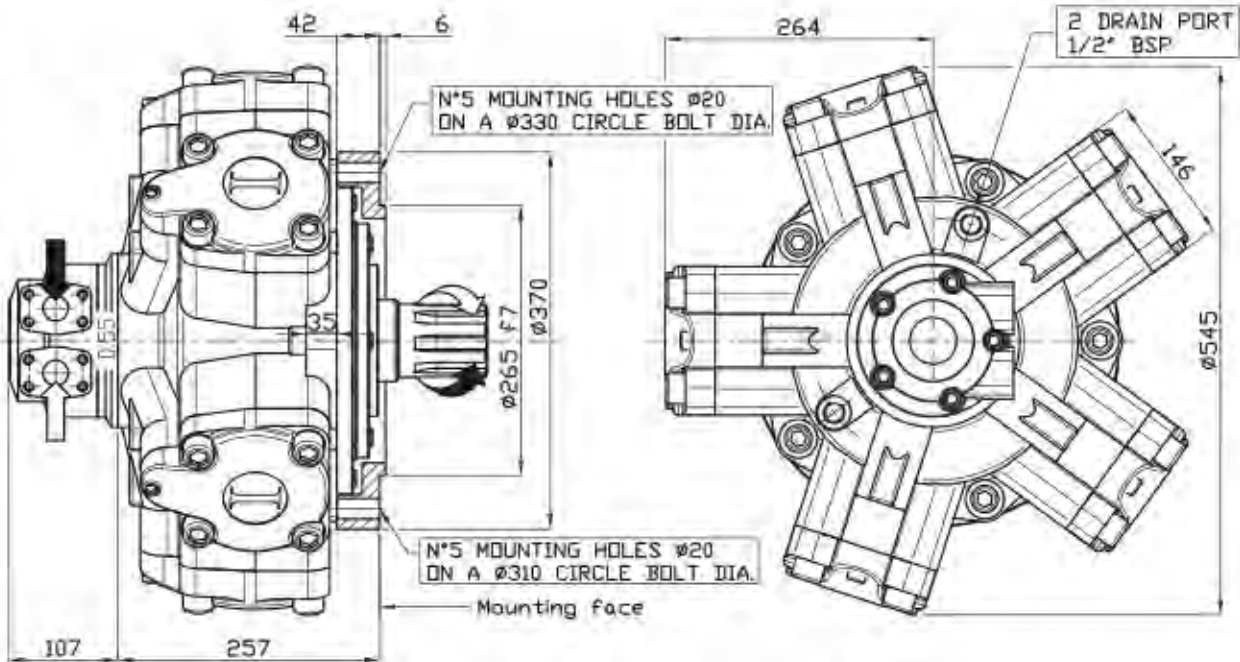

## SHAFT

IAM H5 1000/GM5-1200/GM5-1400/GM5-1500/GM5  
1600/GM5-1800/GM5-2000/GM5-2200/GM5 (S)

A0: Standard splined shaft

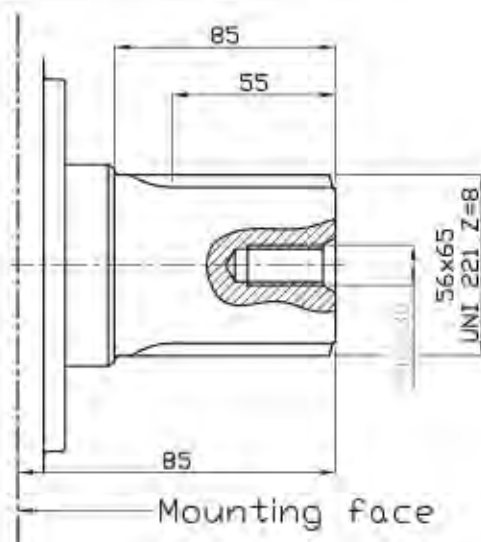

## ORDERING INSTRUCTIONS

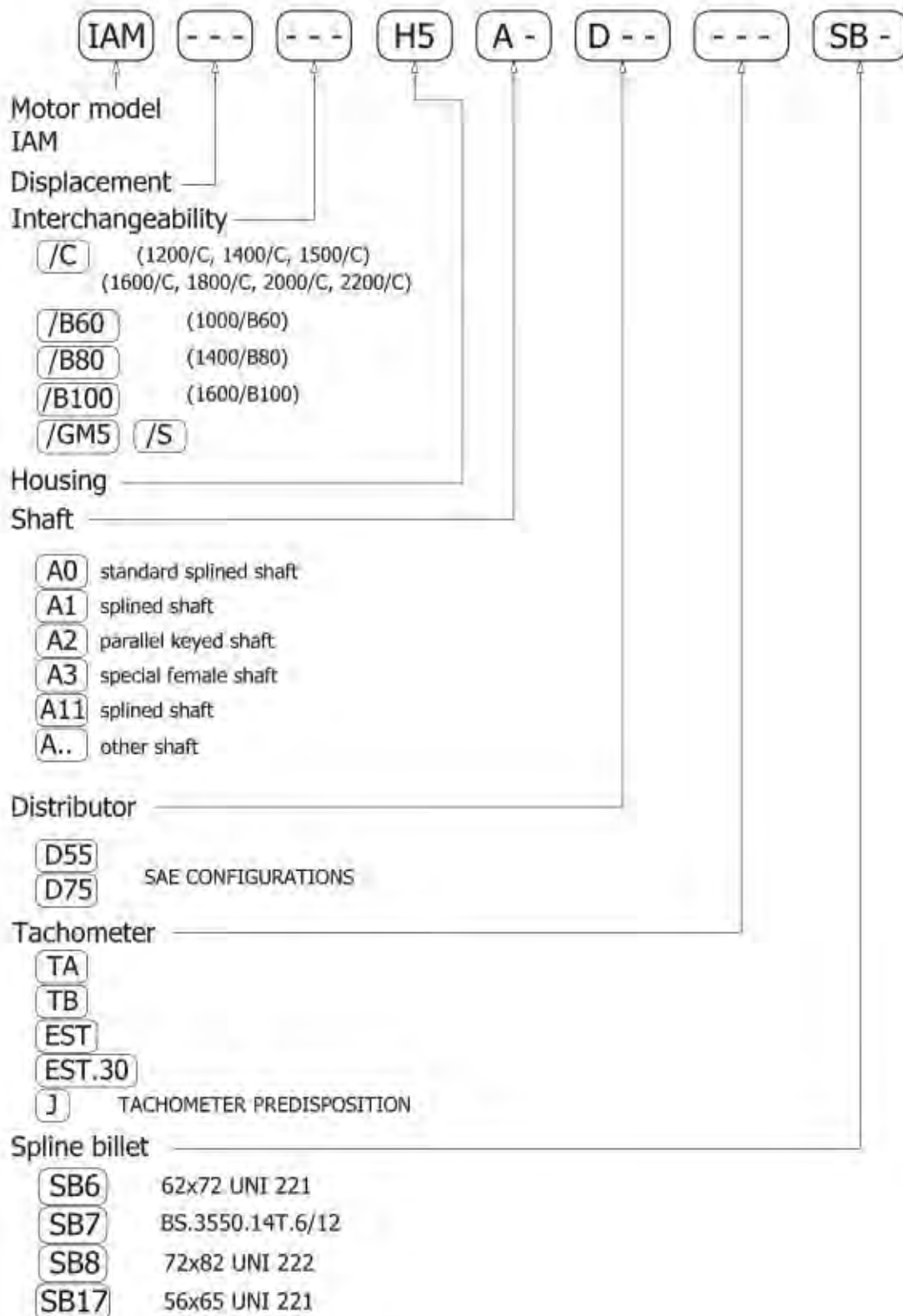

**EXAMPLE:** IAM.1200.H5.A1.D55  
IAM.1600.H5.A0.D75.TA.SB6  
IAM.1800/C.H5.A0.D75.EST30.SB8

### IAM 1000 H5

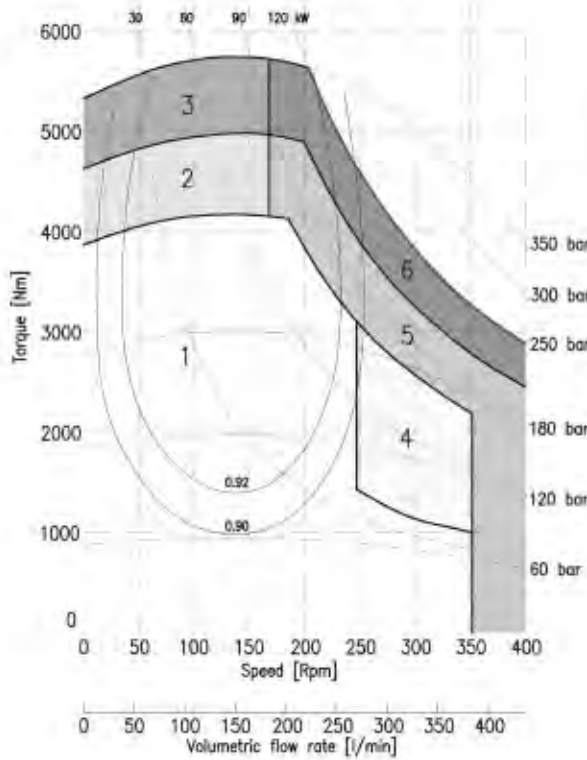

### IAM 1200 H5

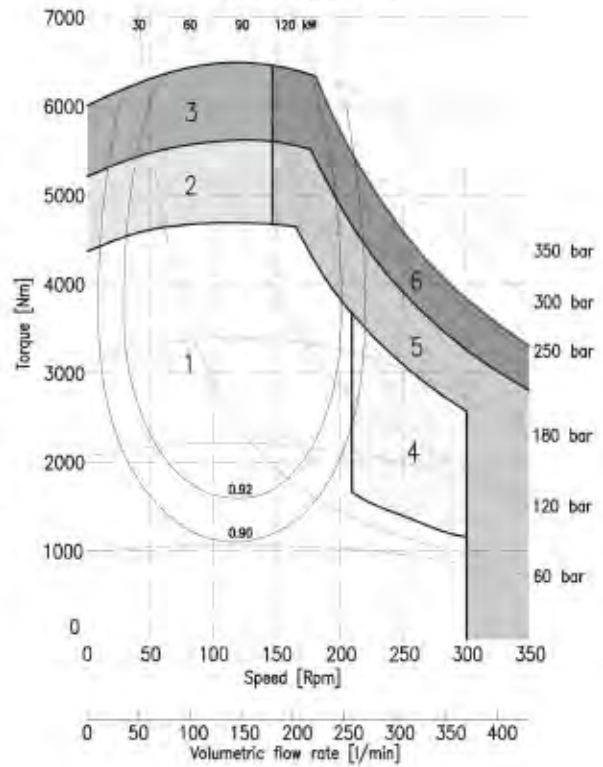

### IAM 1400 H5

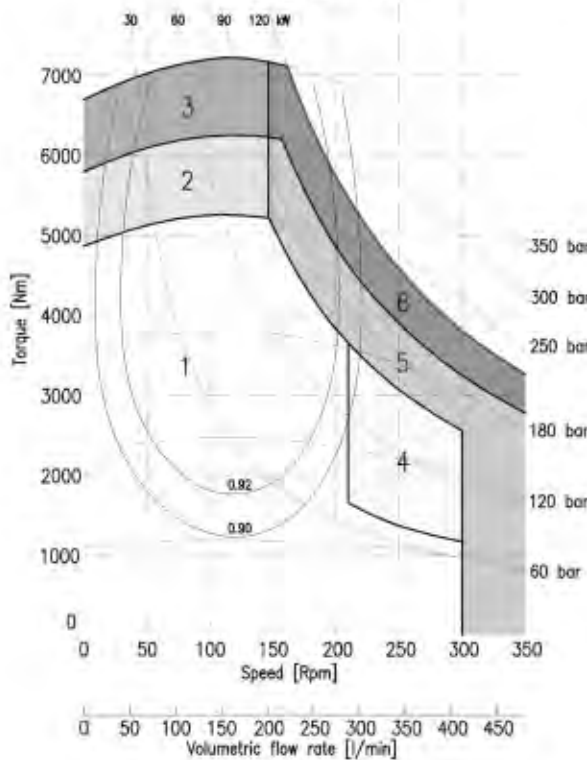

### IAM 1500 H5

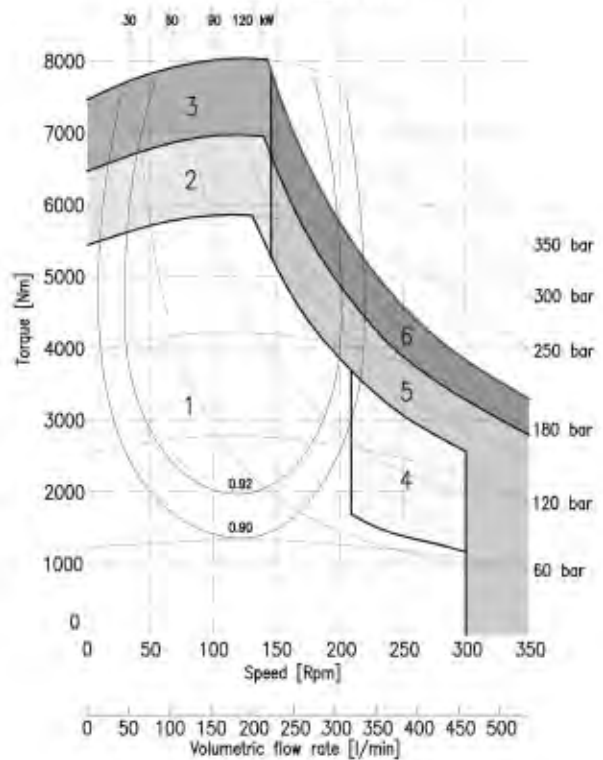

- 1 Continuous operation
- 2 Intermittent operation for period  $\geq 5$  minutes every 10-15 minutes
- 3 Intermittent operation for very short period ( $\geq 5$  seconds every 10-15 minutes)

- 4 Continuous operation with flushing
- 5 Intermittent operation for period  $\geq 5$  minutes every 10-15 minutes with flushing
- 6 Intermittent operation for very short period ( $\geq 5$  seconds every 10-15 minutes) with flushing



### IAM 1600 H5

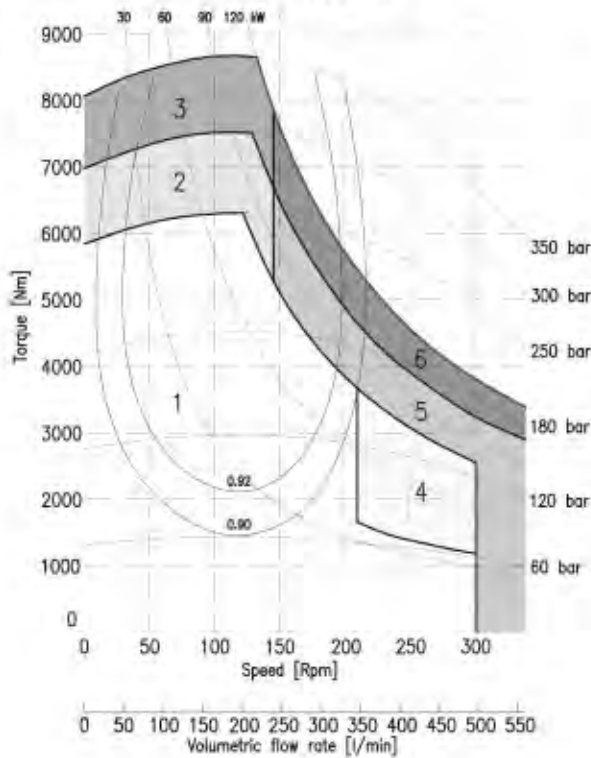

### IAM 1800 H5

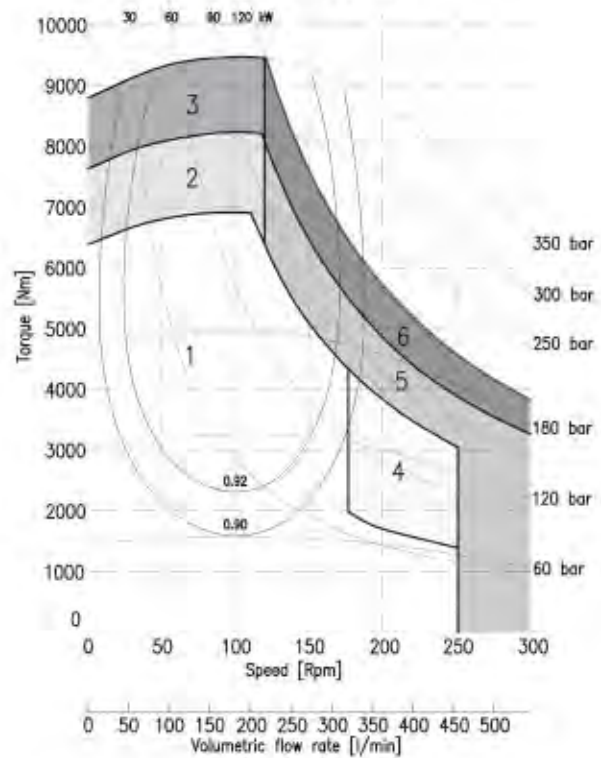

### IAM 2000 H5

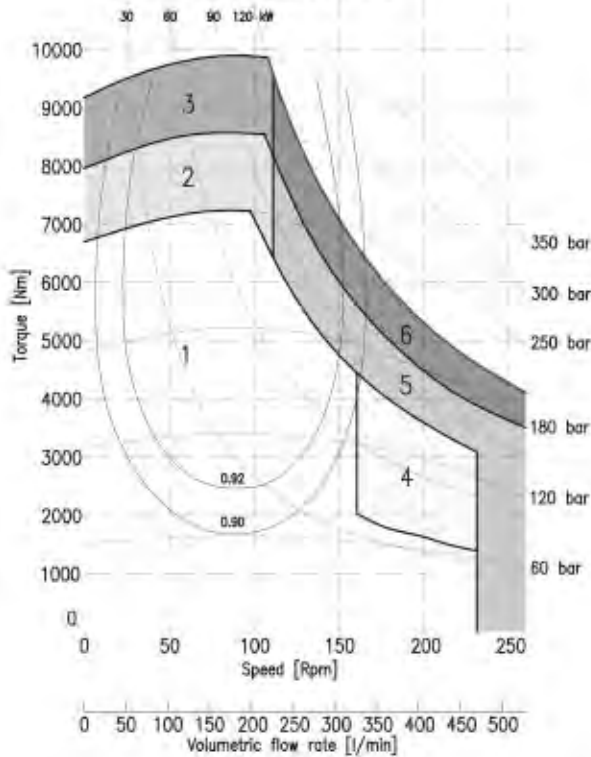

### IAM 2200 H5

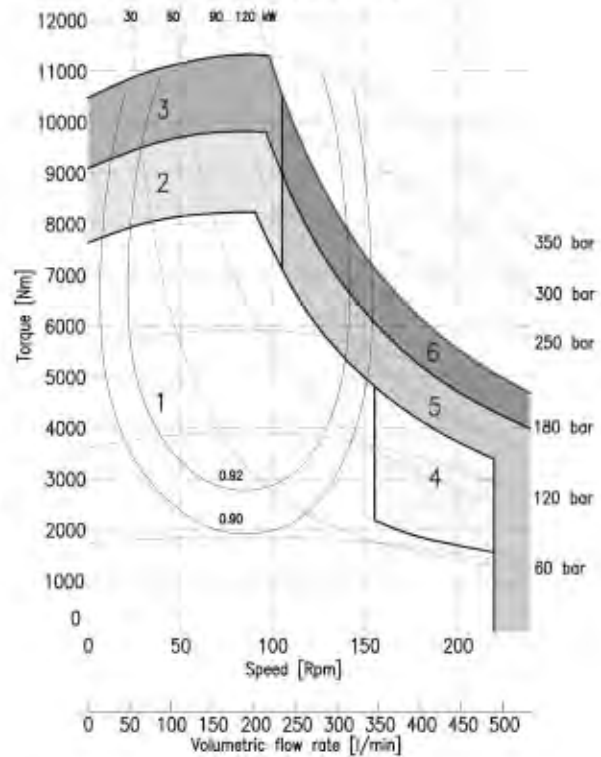

- 1 Continuous operation
- 2 Intermittent operation for period 3-5 minutes every 10-15 minutes
- 3 Intermittent operation for very short period (3-5 seconds every 10-15 minutes)

- 4 Continuous operation with flushing
- 5 Intermittent operation for period 3-5 minutes every 10-15 minutes with flushing
- 6 Intermittent operation for very short period (3-5 seconds every 10-15 minutes) with flushing

---

# ***ITALGROUP - ADVANCED - MOTORS***

## ***IAM SERIES***

### ***H55 MODEL***

---

***IAM 2200-2500-2800 H55***

***IAM 2500-2800-3000/C H55***

---

### ***INDEX***

TECHNICAL DATA - - - - -	Pag.	82
IAM H55 2200-2500-2800 - - - - -	"	83
IAM H55 2500-2800-3000/C - - - - -	"	84
ORDERING INSTRUCTIONS - - - - -	"	85
GRAPHIC PERFORMANCES H55 2200-2500-2800-3000 - - - - -	"	86

## TECHNICAL DATA *H55*

	MODEL	IAM 2200 H55	IAM 2500 H55	IAM 2800 H55	IAM 3000 H55
Displacement	cc/rev	2126	2525	2807	3028
Specific Torque	Nm/bar	33.8	40.2	44.7	48.2
Max cont. Pressure	bar	250	250	250	250
Max int. Pressure	bar	300	300	300	300
Peak pressure	bar	350	350	350	350
Max continuous speed	rpm	240	240	240	230
Peak speed	rpm	280	280	280	270
Max continuous power	HP	163	163	163	163
	kW	120	120	120	120
Max power	HP	228	228	228	228
	kW	170	170	170	170

- N° of pistons: 5
- Max case pressure: 6 bar
- Max back pressure: 70 bar
- Dry weight: 203 kg
- Temperature range: -30°C ÷ +70°C
- Minimum speed: 0.5 rpm
- Flushing flow: 15 l/min

(\*):for further details regarding flushing go to page 10 of this catalogue.



## SIZE

### IAM H55 2200-2500-2800

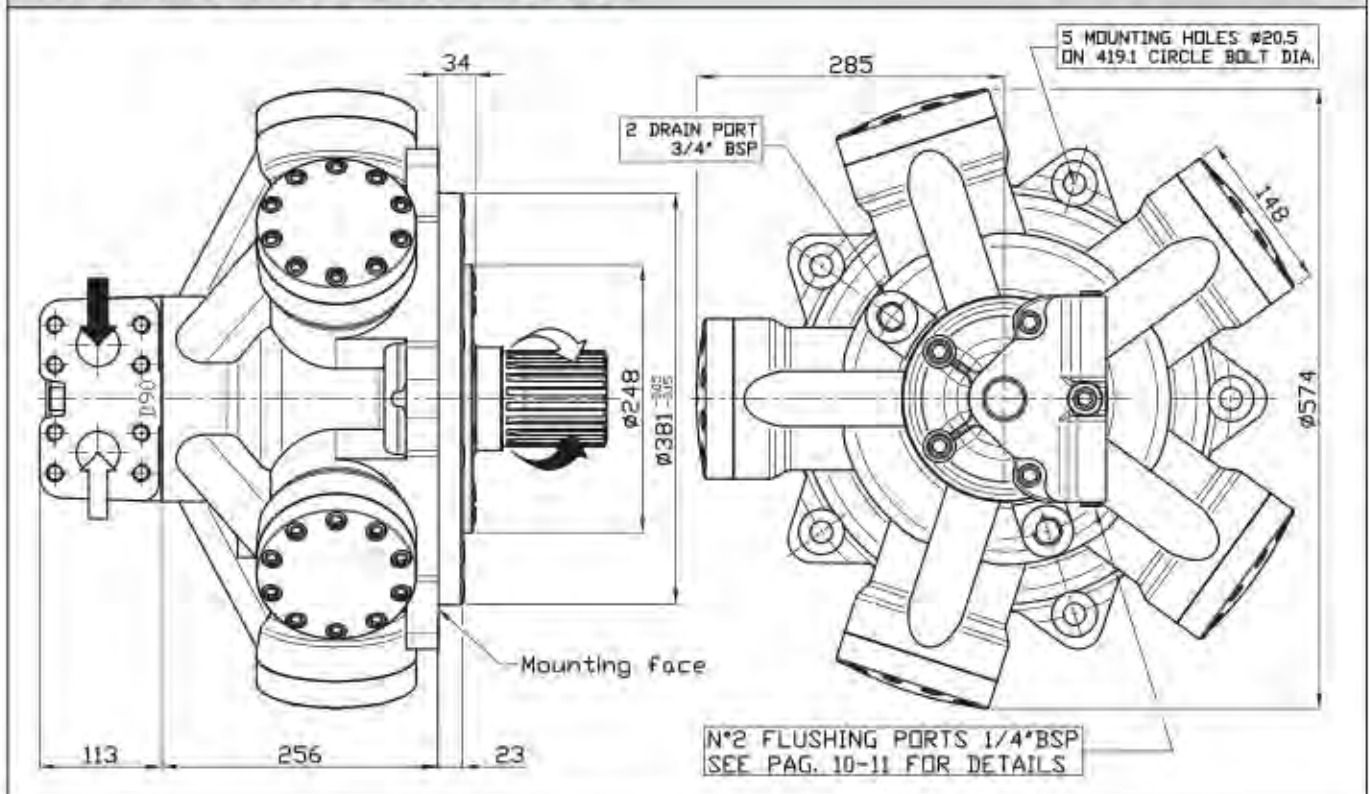

## SHAFT

### IAM H55 2200-2500-2800

A1: Standard splined shaft

A2: Parallel shaft on request

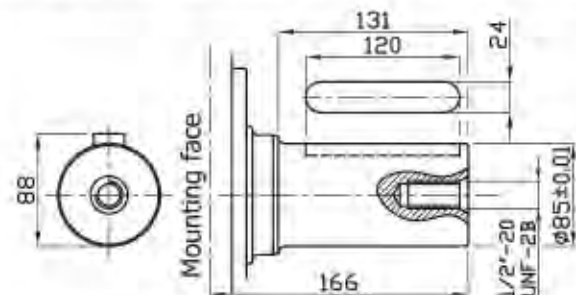
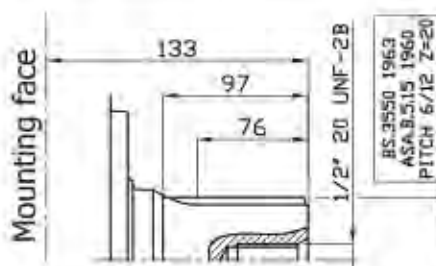

## SIZE

### IAM H55 2500/C-2800/C-3000/C

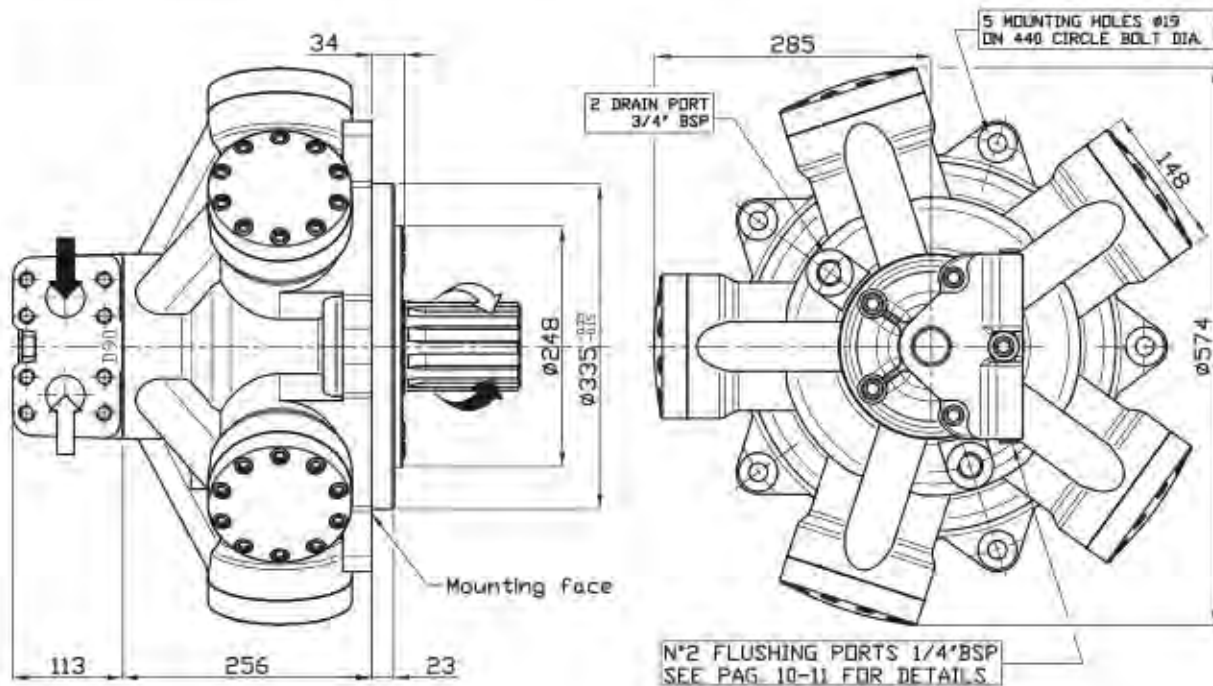

## SHAFT

### IAM H55 2500/C-2800/C-3000/C

A0: Standard splined shaft

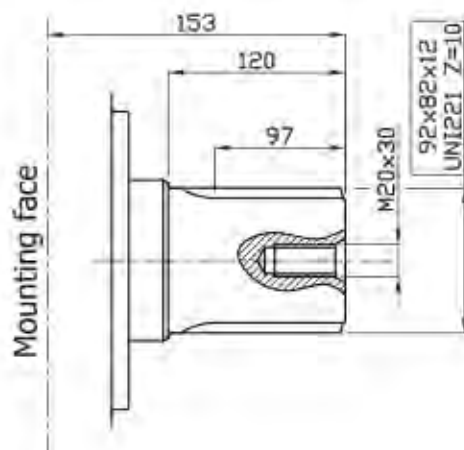

## ORDERING INSTRUCTIONS

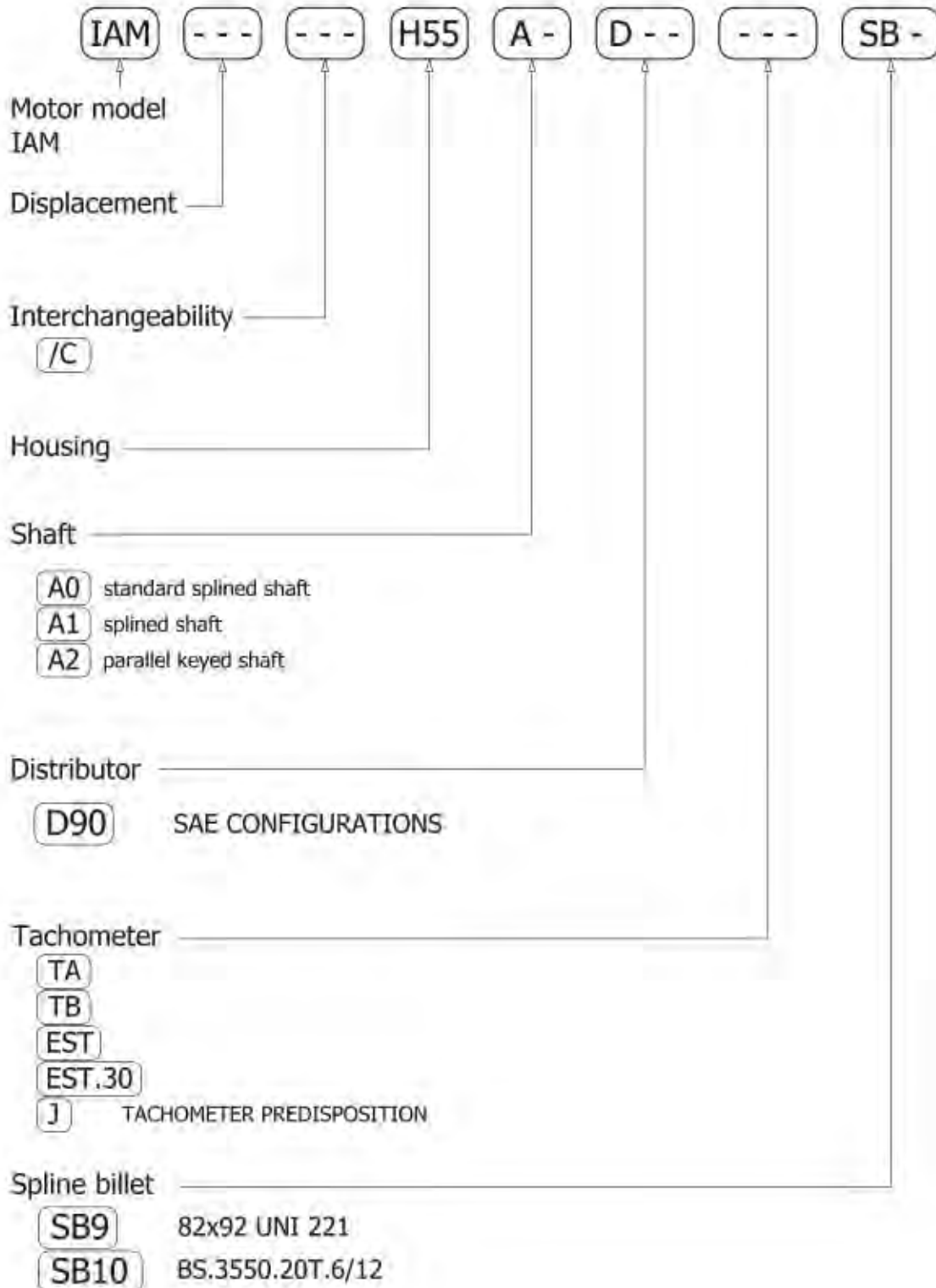

**EXAMPLE:** IAM.2200.H55.A1.D90  
IAM.2800.H55.A2.D90.TA.SB9  
IAM.2500/C.H55.A0.D90



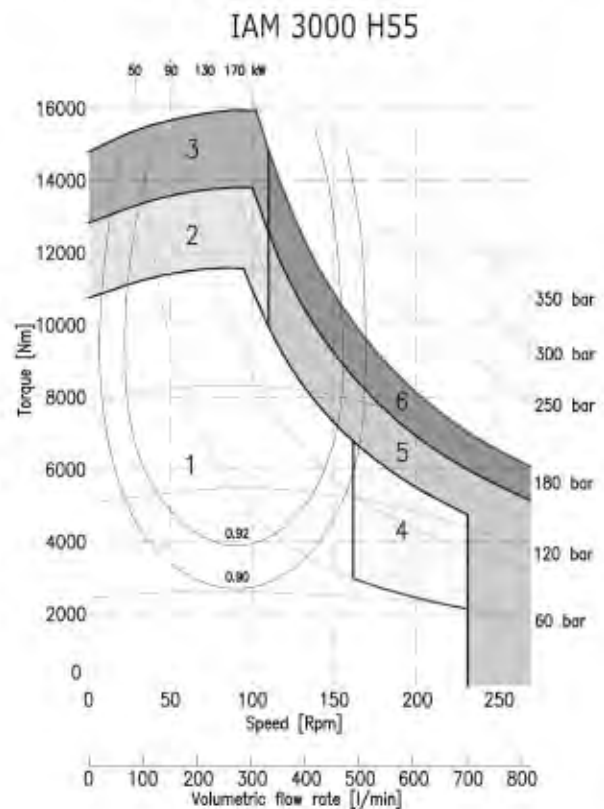
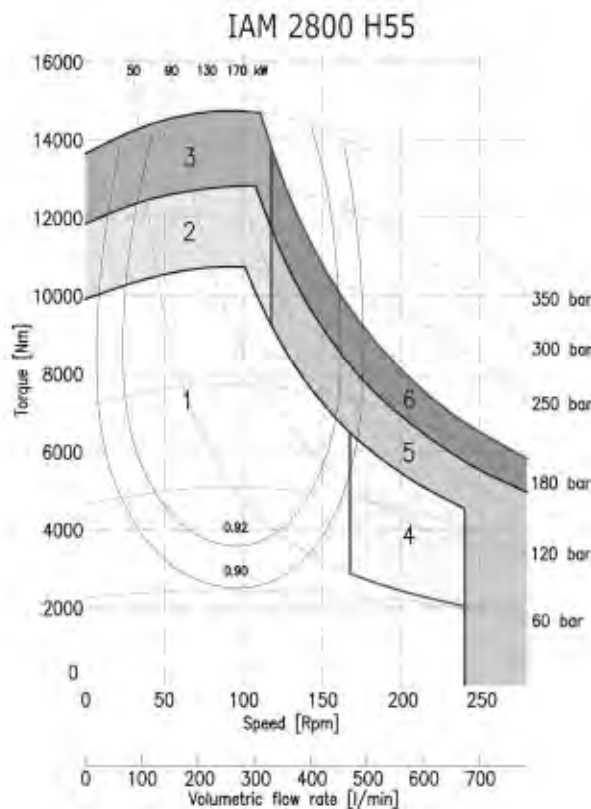
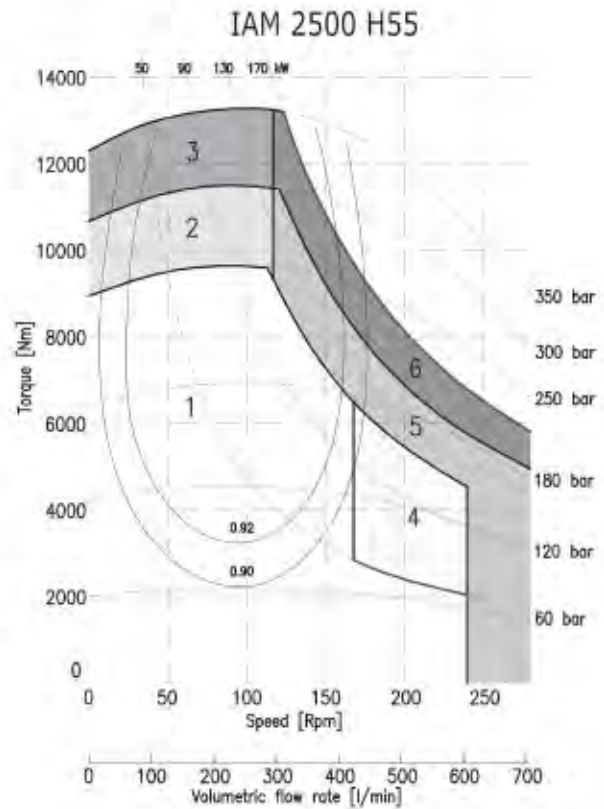
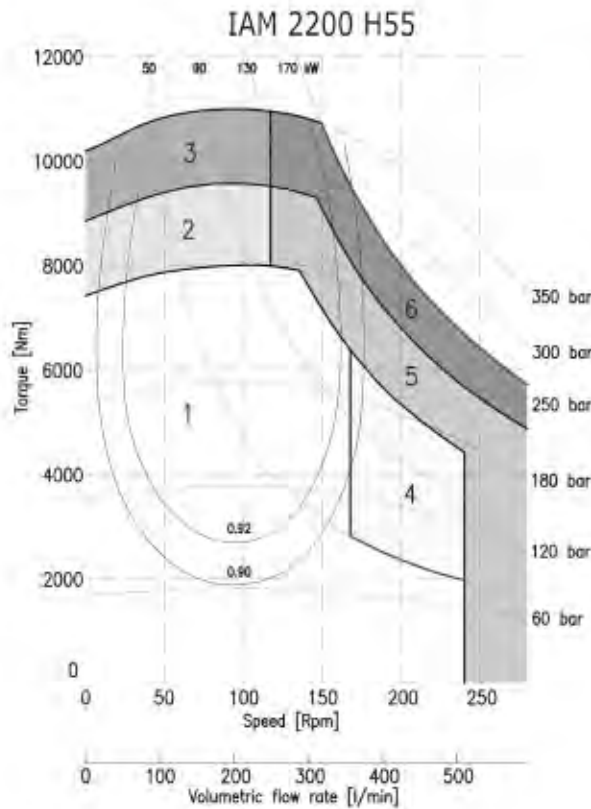

- 1 Continuous operation
- 2 Intermittent operation for period 3-5 minutes every 10-15 minutes
- 3 Intermittent operation for very short period (3-5 seconds) every 10-15 minutes

- 4 Continuous operation with flushing
- 5 Intermittent operation for period 3-5 minutes every 10-15 minutes with flushing
- 6 Intermittent operation for very short period (3-5 seconds) every 10-15 minutes with flushing

---

# ***ITALGROUP-ADVANCED-MOTORS***

## ***IAM SERIES***

---

### ***H6 MODEL***

---

***IAM 2200-2500-2800  
3000-3200-3500 H6***

***IAM 2200-2500-2800  
3000-3200-3500/C H6***

***IAM 2200/B125  
2500/B150  
3000/B200***

---

### ***INDEX***

---

TECHNICAL DATA - - - - -	Pag.	88
IAM H6 2200-2500-2800-3000-3200-3500 - - - - -	"	89
IAM H6 2200-2500-2800-3000-3200-3500/C - - - - -	"	90
IAM H6 2200/B125 2500/B150 3000/B200 - - - - -	"	91
ORDERING INSTRUCTIONS - - - - -	"	92
GRAPHIC PERFORMANCES H6 2200-2500-2800-3000 - - - - -	"	93
GRAPHIC PERFORMANCES H6 3200-3500 - - - - -	"	94

---

# TECHNICAL DATA

# H6

	MODEL	IAM 2200 H6	IAM 2500 H6	IAM 2800 H6	IAM 3000 H6	IAM 3200 H6	IAM 3500 H6
Displacement	cc/rev	2206	2525	2807	2983	3289	3479
Specific Torque	Nm/bar	35.1	40.2	44.7	47.5	52.3	55.4
Max cont. Pressure	bar	250	250	250	250	250	250
Max int. Pressure	bar	300	300	300	300	300	300
Peak pressure	bar	350	350	350	350	350	350
Max continuous speed	rpm	220	220	220	210	200	200
Peak speed	rpm	260	260	260	250	240	240
Max continuous power	HP	163	163	163	163	163	163
	kW	120	120	120	120	120	120
Max power	HP	228	228	228	228	228	228
	kW	170	170	170	170	170	170

- N° of pistons: 5
- Max case pressure: 6 bar
- Max back pressure: 70 bar
- Dry weight: 308 kg
- Temperature range: -30°C ÷ +70°C
- Minimum speed: 0.5 rpm
- Flushing flow: 15 l/min

(\*):for further details regarding flushing go to page 10 of this catalogue.



## SIZE

### IAM 2200-2500-2800-3000-3200-3500 H6

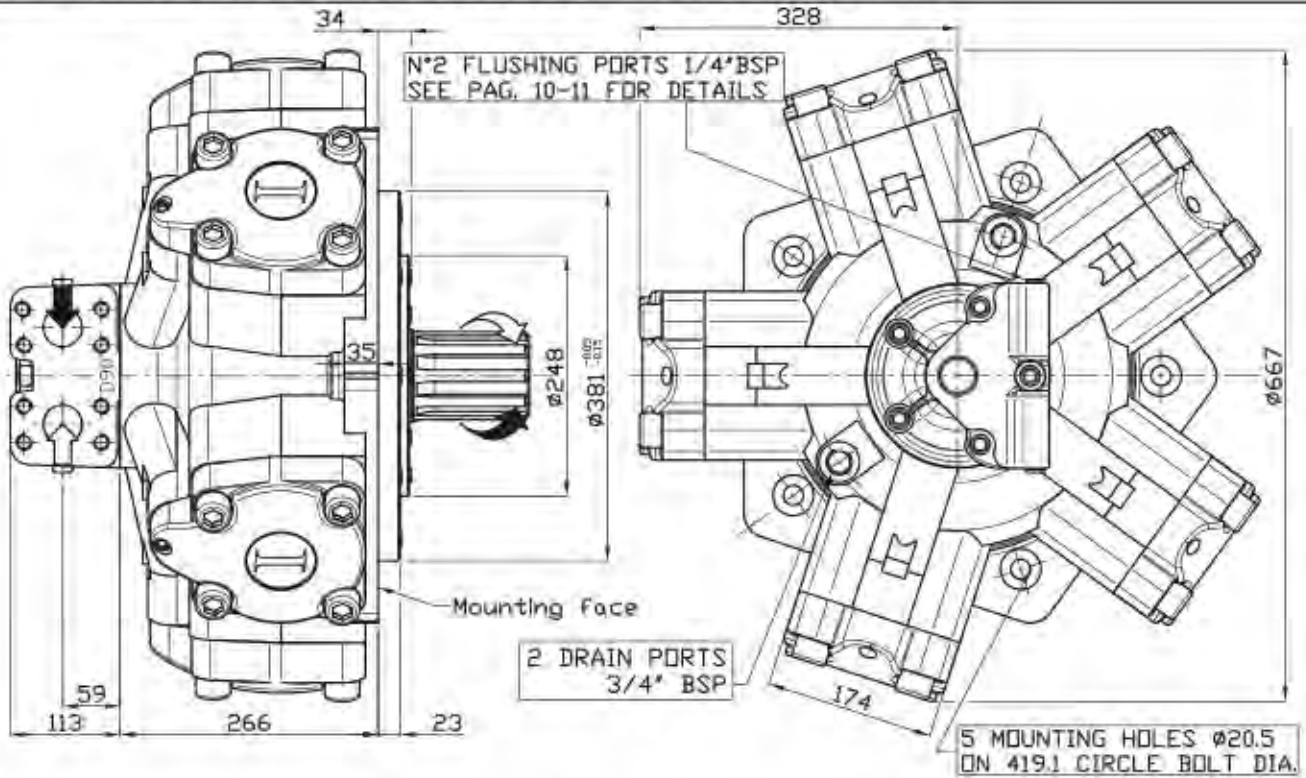

## SHAFT

### IAM 2200-2500-2800-3000-3200-3500 H6

A0: Standard splined shaft

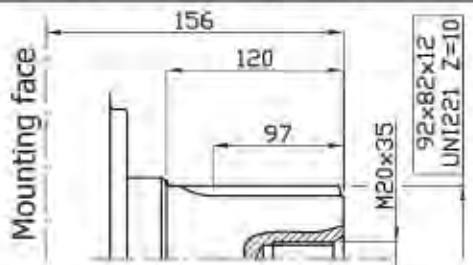

A1: Splined shaft on request

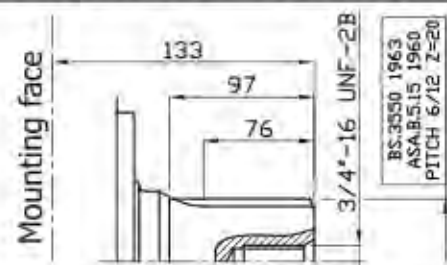

A2: Parallel shaft on request

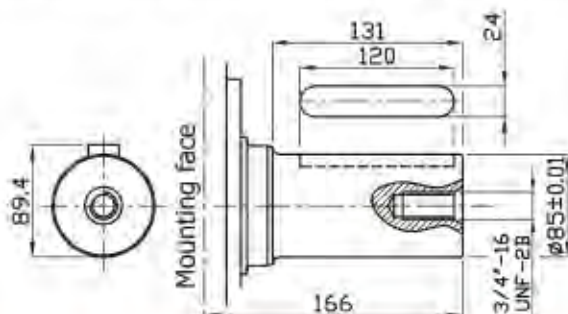

## SIZE

### IAM 2200/C-2500/C-2800/C-3000/C-3200/C-3500/C H6

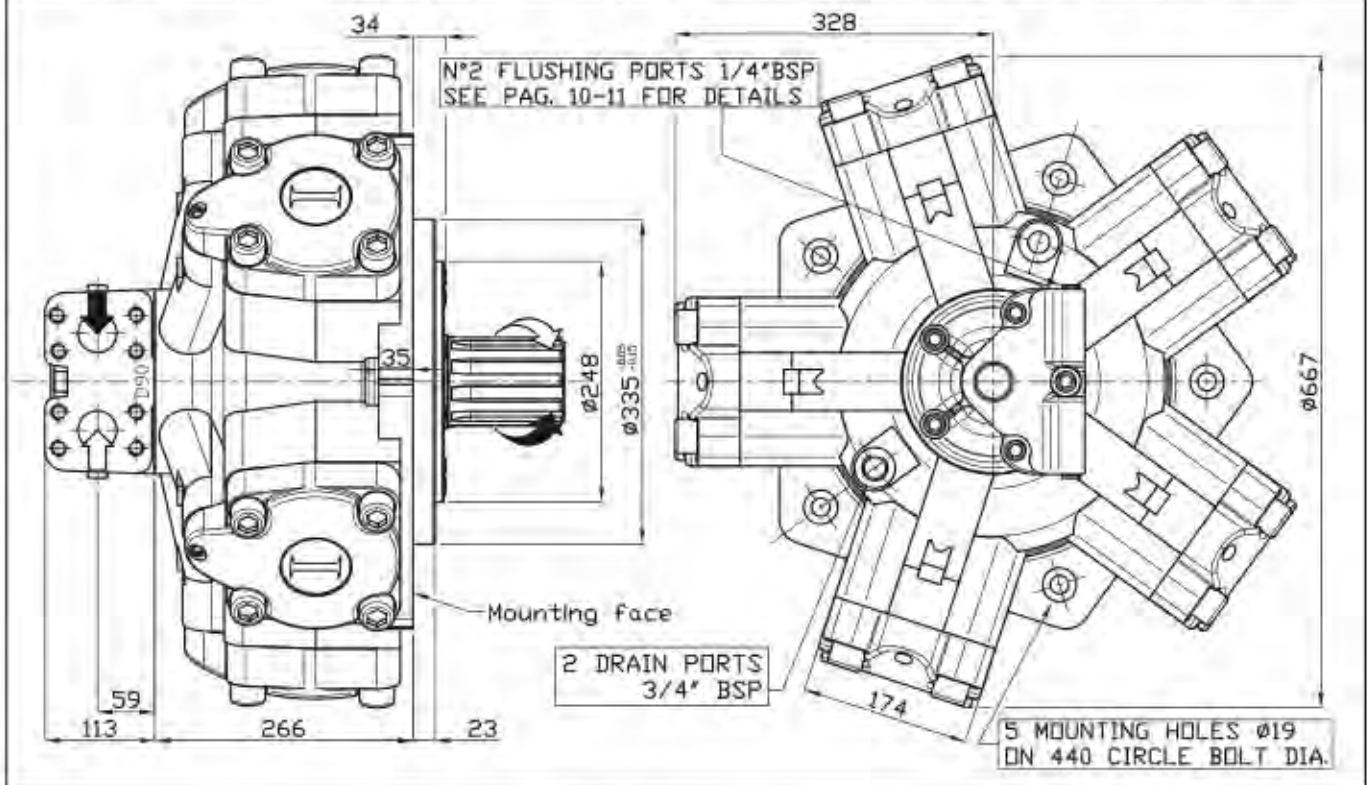

## SHAFT

### IAM 2200/C-2500/C-2800/C-3000/C-3200/C-3500/C H6

A0: Standard splined shaft

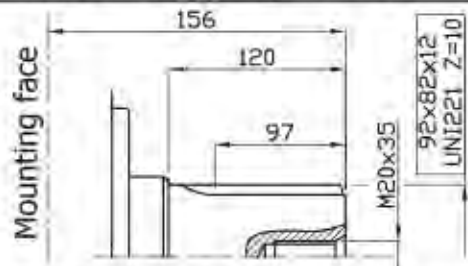

A1: Splined shaft on request

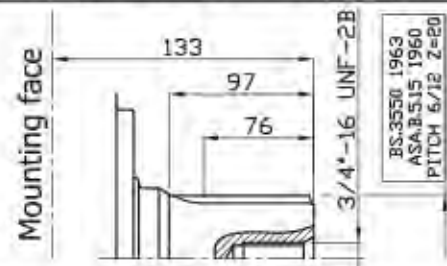

A2: Parallel shaft on request

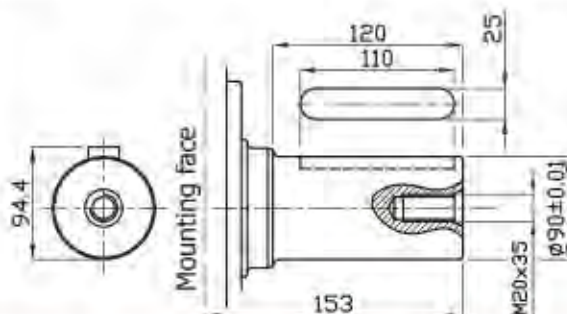

A3: Female shaft on request

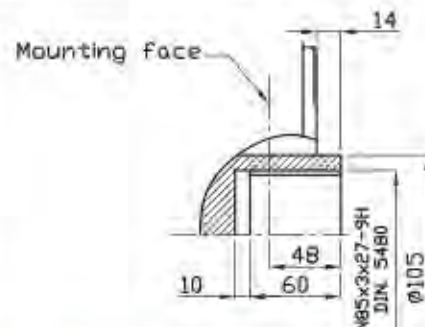



## SIZE

### IAM 2200/B125-2500/B150-3000/B200 H6

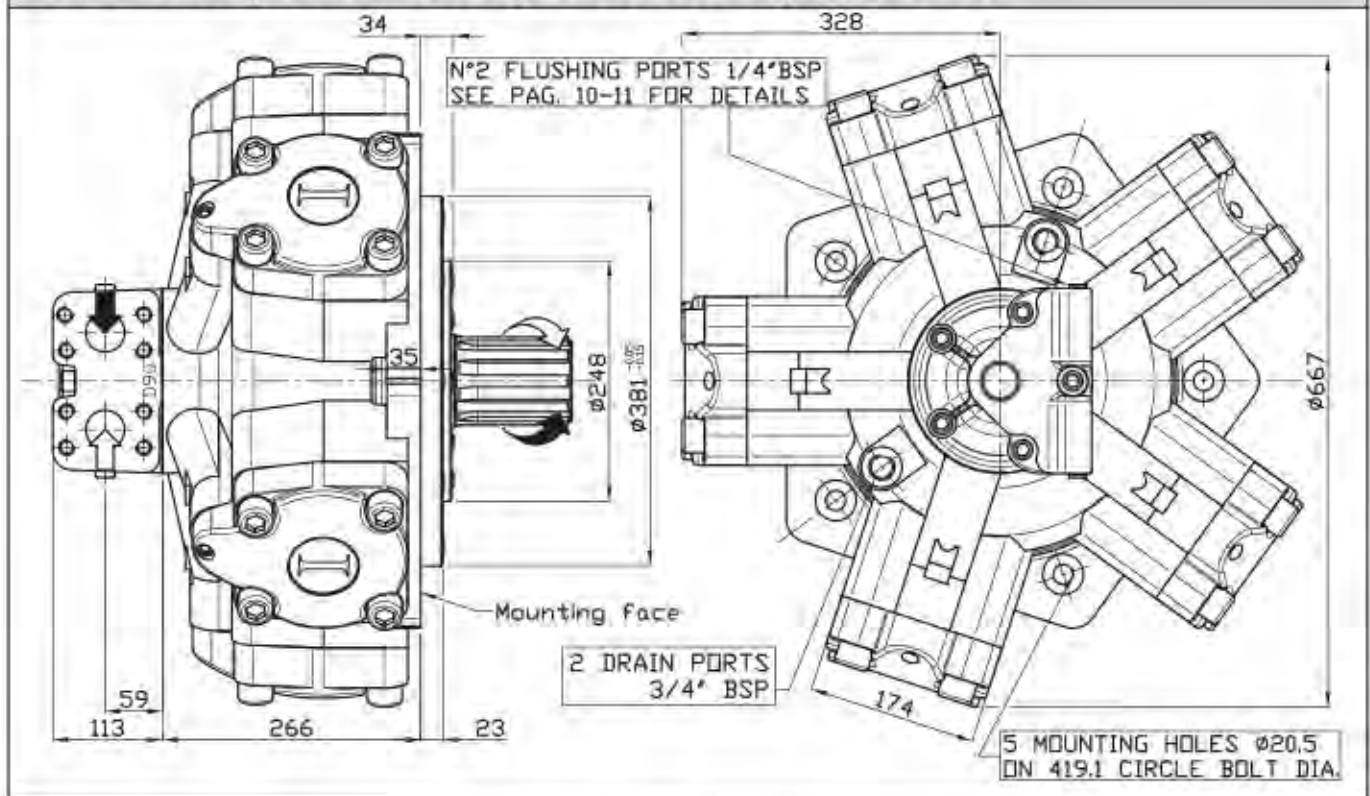

## SHAFT

### IAM 2200/B125-2500/B150-3000/B200 H6

<p><b>A0: Standard splined shaft</b></p>	<p><b>A1:</b> Splined Shaft on request</p>
<p><b>A2: Parallel shaft on request</b></p>	<p><b>A11:</b> Splined Shaft on request</p>
	<p><b>A12:</b> Splined Shaft on request</p>



## ORDERING INSTRUCTIONS

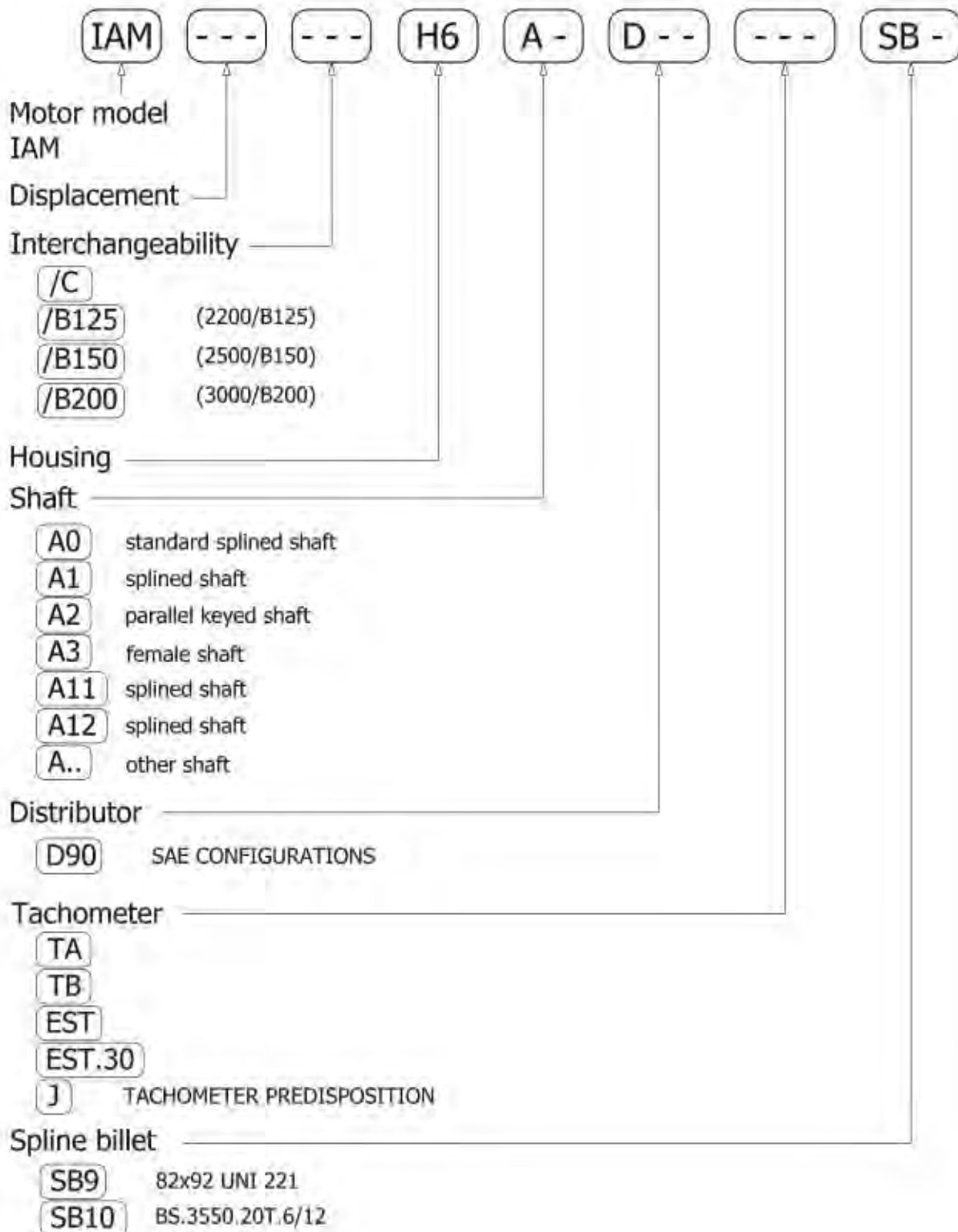

**EXAMPLE:** IAM.2500.H6.A1.D90  
IAM.2800.H6.A0.D90.TA.SB9  
IAM.2500/C.H6.A2.D90.J

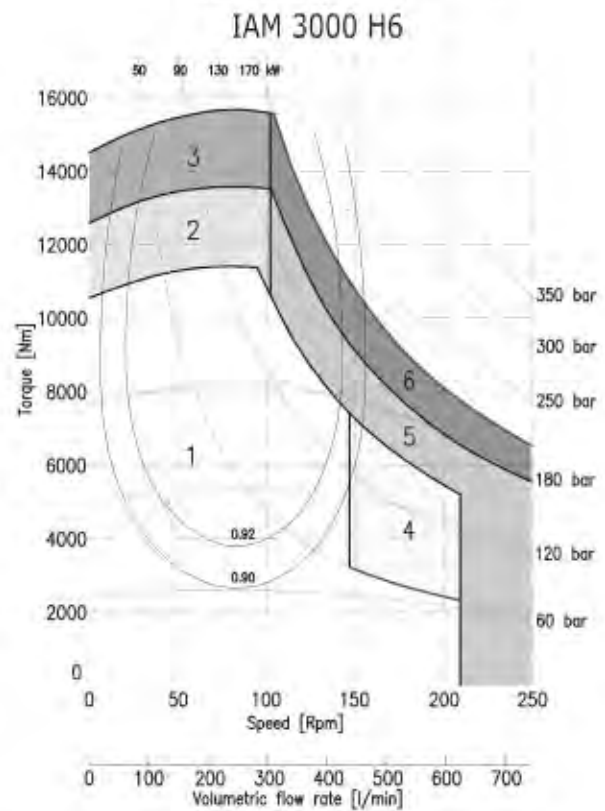
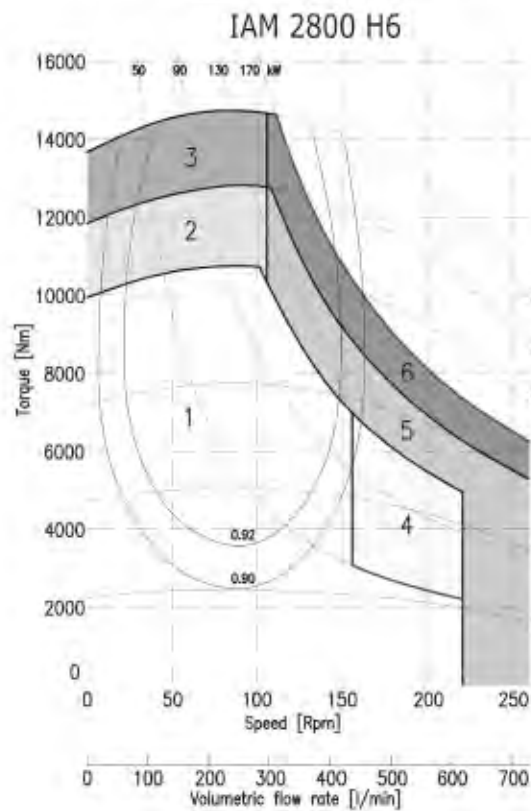
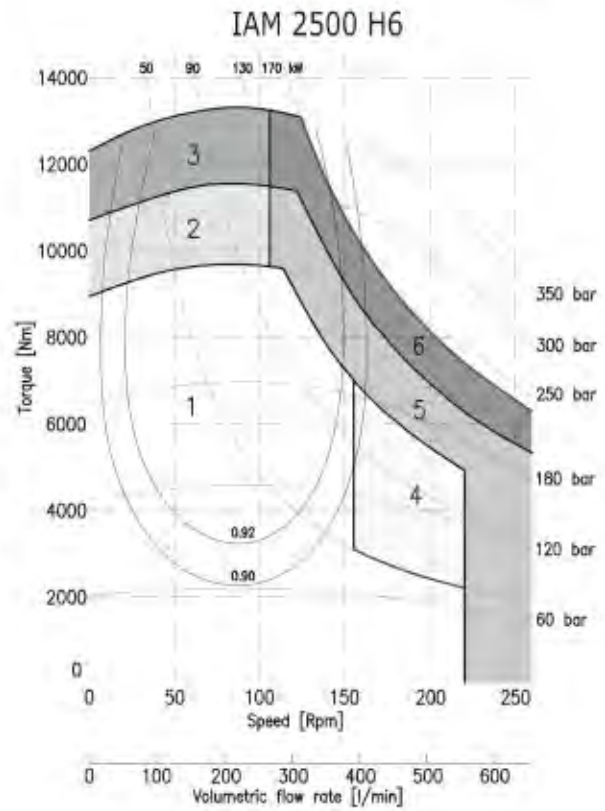
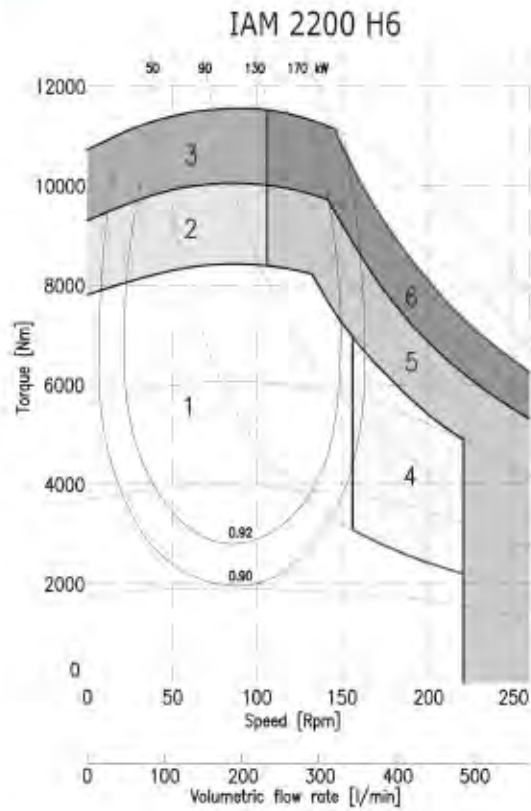

- 1 Continuous operation
- 2 Intermittent operation for period 3-5 minutes every 10-15 minutes
- 3 Intermittent operation for very short period (3-5 seconds every 10-15 minutes)

- 4 Continuous operation with flushing
- 5 Intermittent operation for period 3-5 minutes every 10-15 minutes with flushing
- 6 Intermittent operation for very short period (3-5 seconds every 10-15 minutes) with flushing

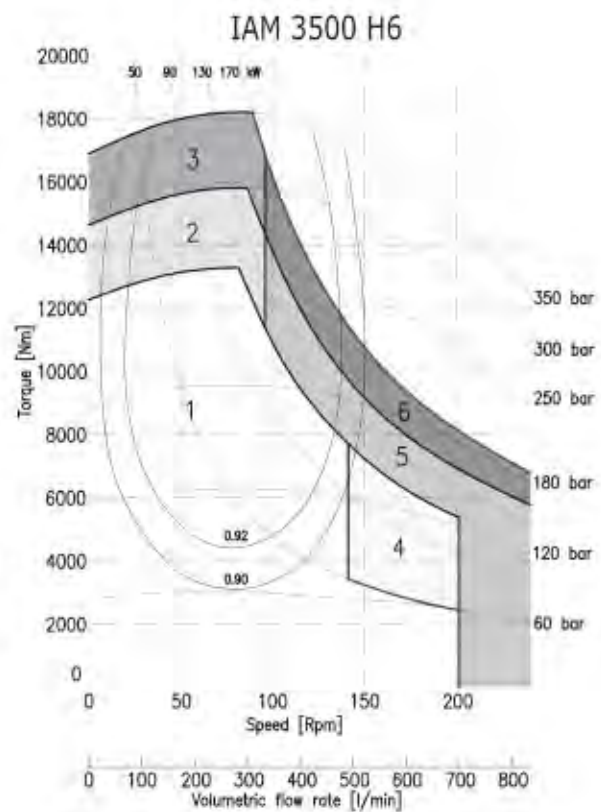
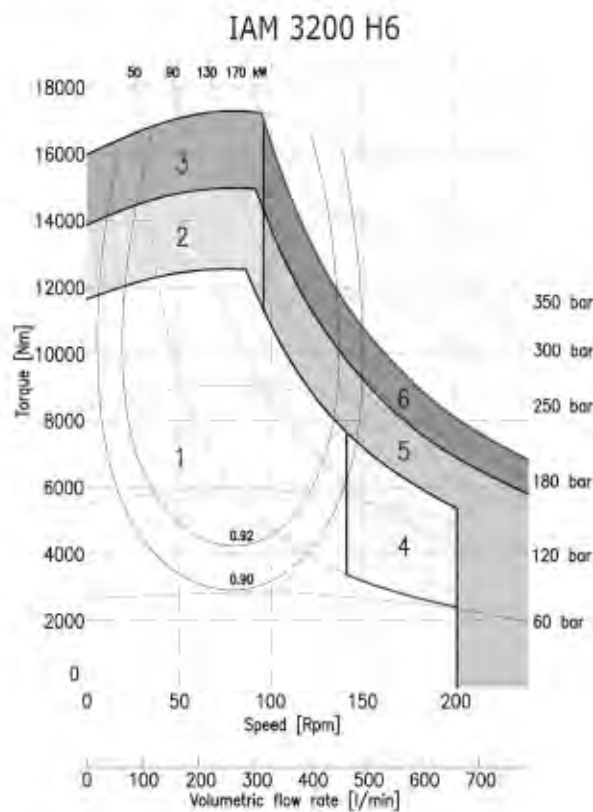

1	Continuous operation
2	Intermittent operation for period 3-5 minutes every 10-15 minutes
3	Intermittent operation for very short period (3-5 seconds) every 10-15 minutes

4	Continuous operation with flushing
5	Intermittent operation for period 3-5 minutes every 10-15 minutes with flushing
6	Intermittent operation for very short period (3-5 seconds) every 10-15 minutes with flushing



---

# ***ITALGROUP - ADVANCED - MOTORS***

## ***IAM SERIES***

---

### ***H7 MODEL***

---

***IAM 3900-4300-4600-  
5000-5400 H7***

***IAM 3900-4300-4600-  
5000-5400/C H7***

---

### ***INDEX***

---

TECHNICAL DATA - - - - -	Pag.	96
IAM H7 3900-4300-4600-5000-5400 - - - - -	"	97
IAM H7 3900-4300-4600-5000-5400/C - - - - -	"	98
ORDERING INSTRUCTIONS - - - - -	"	99
GRAPHIC PERFORMANCES H7 3900-4300-4600-5000 - - - - -	"	100
GRAPHIC PERFORMANCES H7 5400 - - - - -	"	101

---

	MODEL	IAM 3900 H7	IAM 4300 H7	IAM 4600 H7	IAM 5000 H7	IAM 5400 H7
Displacement	cc/rev	3907	4343	4616	5088	5384
Specific Torque	Nm/bar	62.2	69.1	73.5	81.0	85.7
Max cont. Pressure	bar	250	250	250	250	250
Max int. Pressure	bar	300	300	300	300	300
Peak pressure	bar	350	350	350	350	350
Max continuous speed	rpm	160	150	140	140	130
Peak speed	rpm	200	190	190	180	170
Max continuous power	HP	177	177	177	177	177
	kW	130	130	130	130	130
Max power	HP	241	241	241	241	241
	kW	180	180	180	180	180

- N° of pistons: 7
- Max case pressure: 6 bar
- Max back pressure: 70 bar
- Dry weight: 405 kg
- Temperature range: -30°C ÷ +70°C
- Minimum speed: 0.5 rpm
- Flushing flow: 20 l/min

(\*)for further details regarding flushing go to page 10 of this catalogue.

## SIZE

### IAM 3900-4300-4600-5000-5400 H7

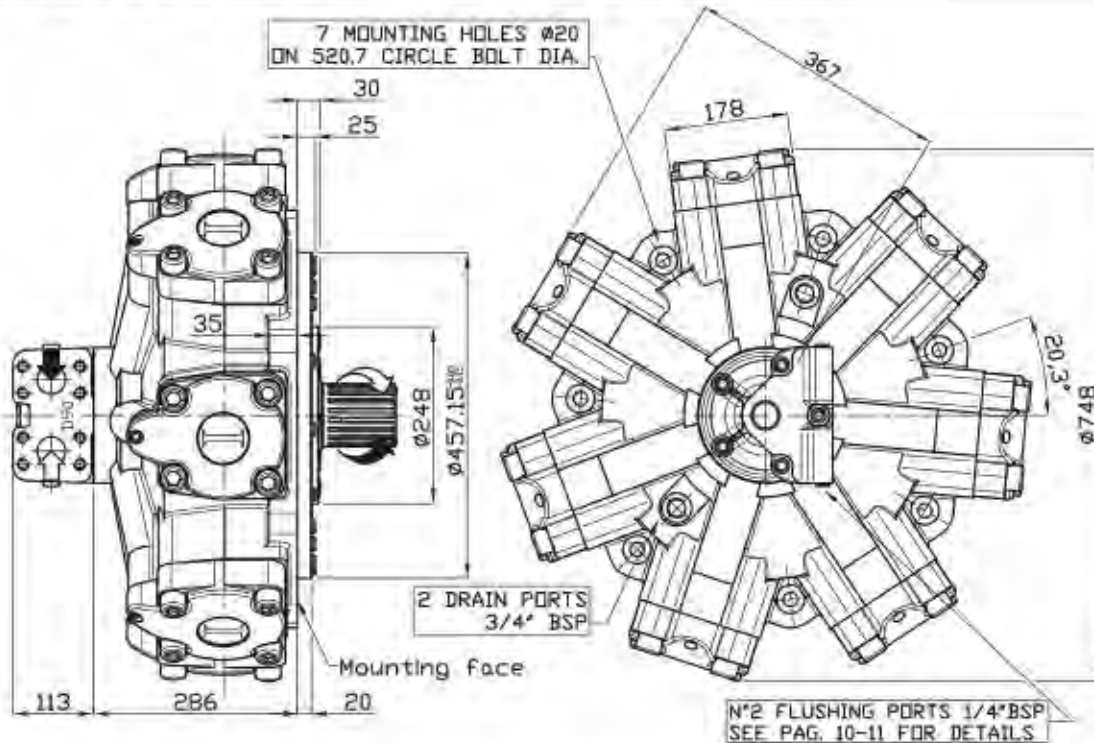

## SHAFT

### IAM 3900-4300-4600-5000-5400 H7

A1: Standard splined shaft

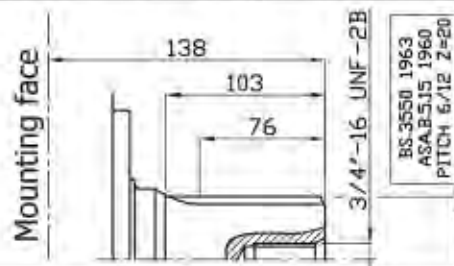

A4: Taper shaft on request

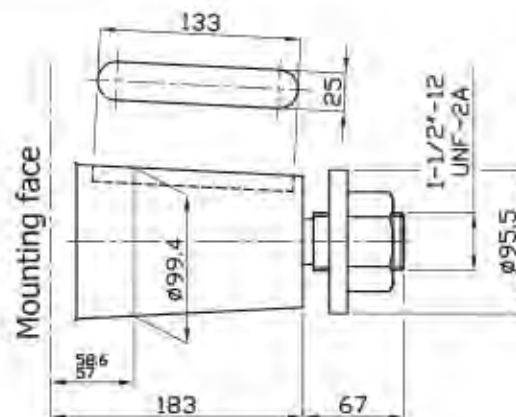

A2: Parallel shaft on request

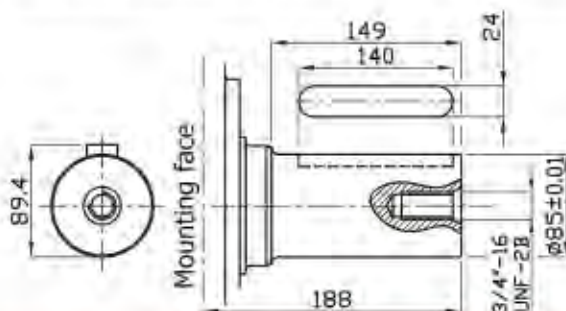



## SIZE

### IAM 3900/C-4300/C-4600/C-5000/C-5400/C H7

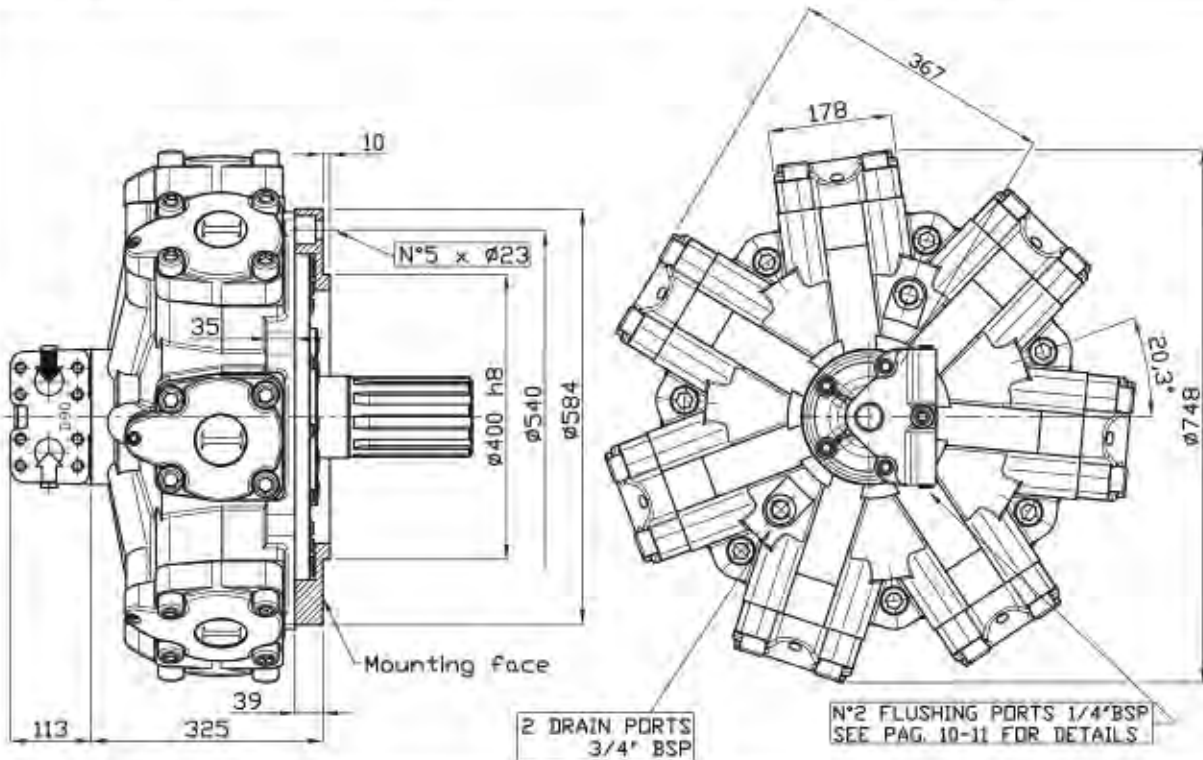

## SHAFT

### IAM 3900/C-4300/C-4600/C-5000/C-5400/C H7

A0: Standard splined shaft

A2: Parallel shaft on request

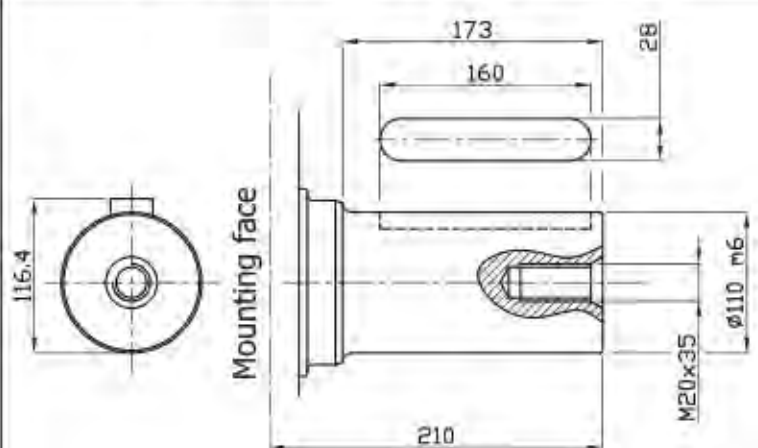
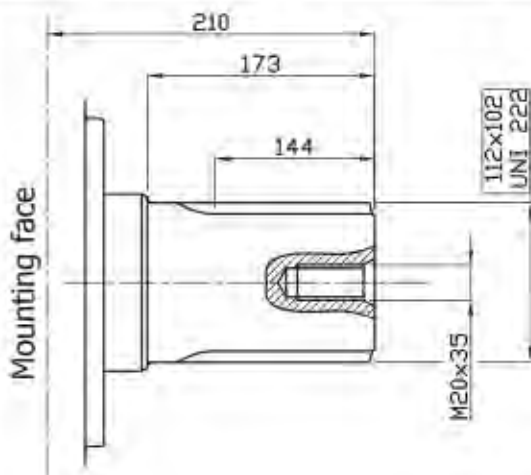

## ORDERING INSTRUCTIONS

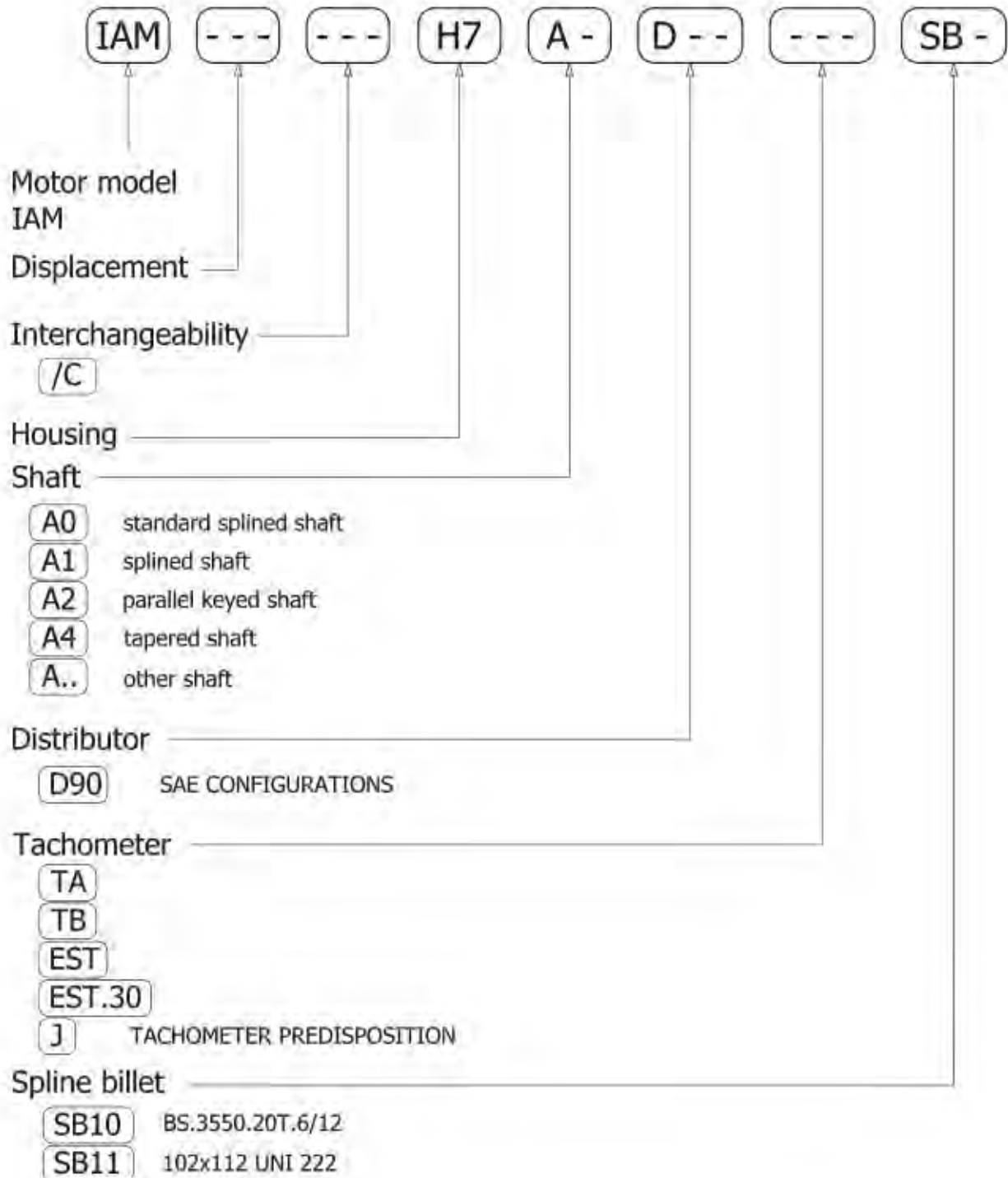

**EXAMPLE:** IAM.3900.H7.A1.D90  
IAM.4600.H7.A1.D90.TA.SB10  
IAM.5400/C.H7.A2.D90.J

### IAM 3900 H7

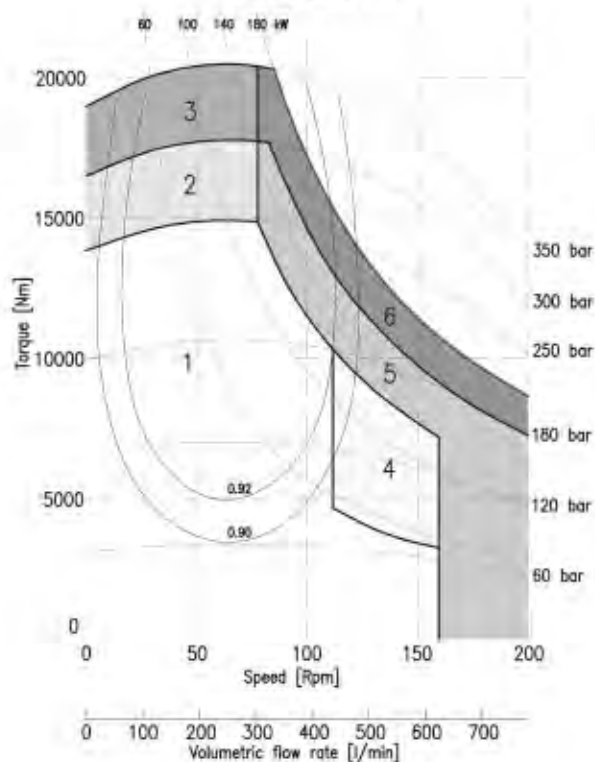

### IAM 4300 H7

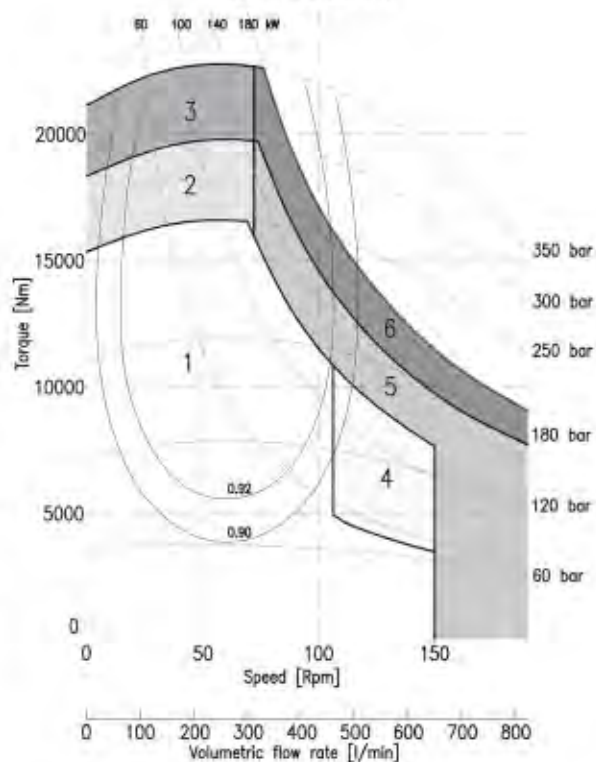

### IAM 4600 H7

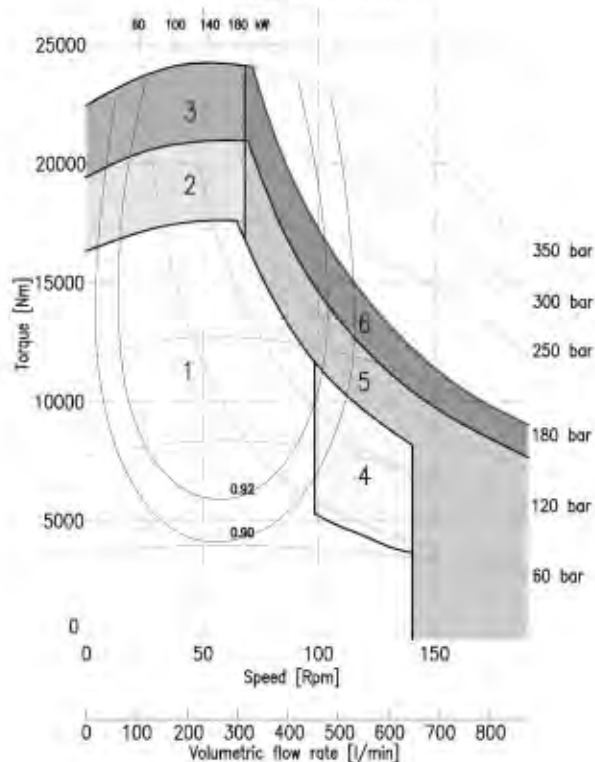

### IAM 5000 H7

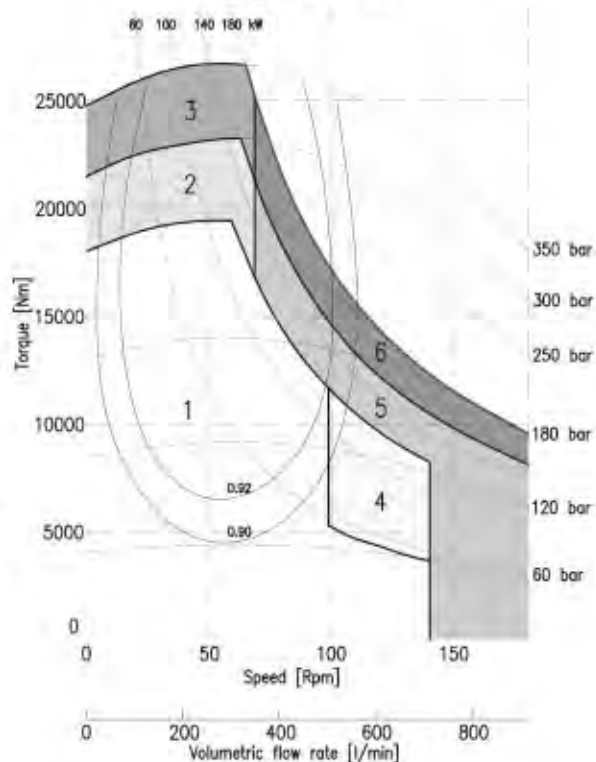

1	Continuous operation
2	Intermittent operation for period 3-5 minutes every 10-15 minutes
3	Intermittent operation for very short period (3-5 seconds) every 10-15 minutes

4	Continuous operation with flushing
5	Intermittent operation for period 3-5 minutes every 10-15 minutes with flushing
6	Intermittent operation for very short period (3-5 seconds) every 10-15 minutes with flushing



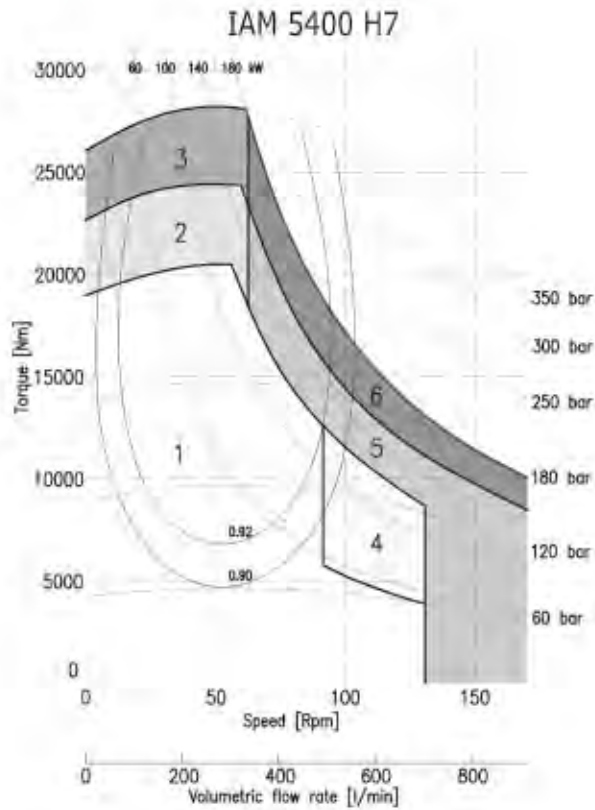

- 1 Continuous operation
- 2 Intermittent operation for period 3-5 minutes every 10-15 minutes
- 3 Intermittent operation for very short period (3-5 seconds every 10-15 minutes)

- 4 Continuous operation with flushing
- 5 Intermittent operation for period 3-5 minutes every 10-15 minutes with flushing
- 6 Intermittent operation for very short period (3-5 seconds every 10-15 minutes) with flushing



---

# ***ITALGROUP - ADVANCED - MOTORS***

---

## ***IAM SERIES***

---

### ***H8 MODEL***

---

***IAM 6000-6500-6800-  
7600-8000 H8***

***IAM 6000-6500-6800-  
7600-8000 H8***

---

### ***INDEX***

TECHNICAL DATA -----	<i>Pag.</i>	104
IAM H8 6000-6500-6800-7600-8000 -----	"	105
IAM H8 6000-6500-6800-7600-8000/C -----	"	106
ORDERING INSTRUCTIONS -----	"	107
GRAPHIC PERFORMANCES H8 6000-6500-6800-7600 -----	"	108
GRAPHIC PERFORMANCES H8 8000 -----	"	109



# TECHNICAL DATA

# H8

	MODEL	IAM 6000 H8	IAM 6500 H8	IAM 6800 H8	IAM 7600 H8	IAM 8000 H8
Displacement	cc/rev	5966	6581	6962	7620	8062
Specific Torque	Nm/bar	95.0	104.7	110.8	121.3	128.3
Max cont. Pressure	bar	250	250	250	190	180
Max int. Pressure	bar	290	290	290	230	220
Peak pressure	bar	320	320	320	280	270
Max continuous speed	rpm	120	120	120	90	80
Peak speed	rpm	140	140	140	100	90
Max continuous power	HP	183	183	183	177	177
	kW	135	135	135	130	130
Max power	HP	255	255	255	241	241
	kW	190	190	190	180	180

- N° of pistons: 10
- Max case pressure: 6 bar
- Max back pressure: 70 bar
- Dry weight: 590 kg
- Temperature range: -30°C ÷ +70°C
- Minimum speed: 0.5 rpm
- Flushing flow: 20 l/min

(\* )for further details regarding flushing go to page 10 of this catalogue.

## SIZE

### IAM 6000-6500-6800-7600-8000 H8

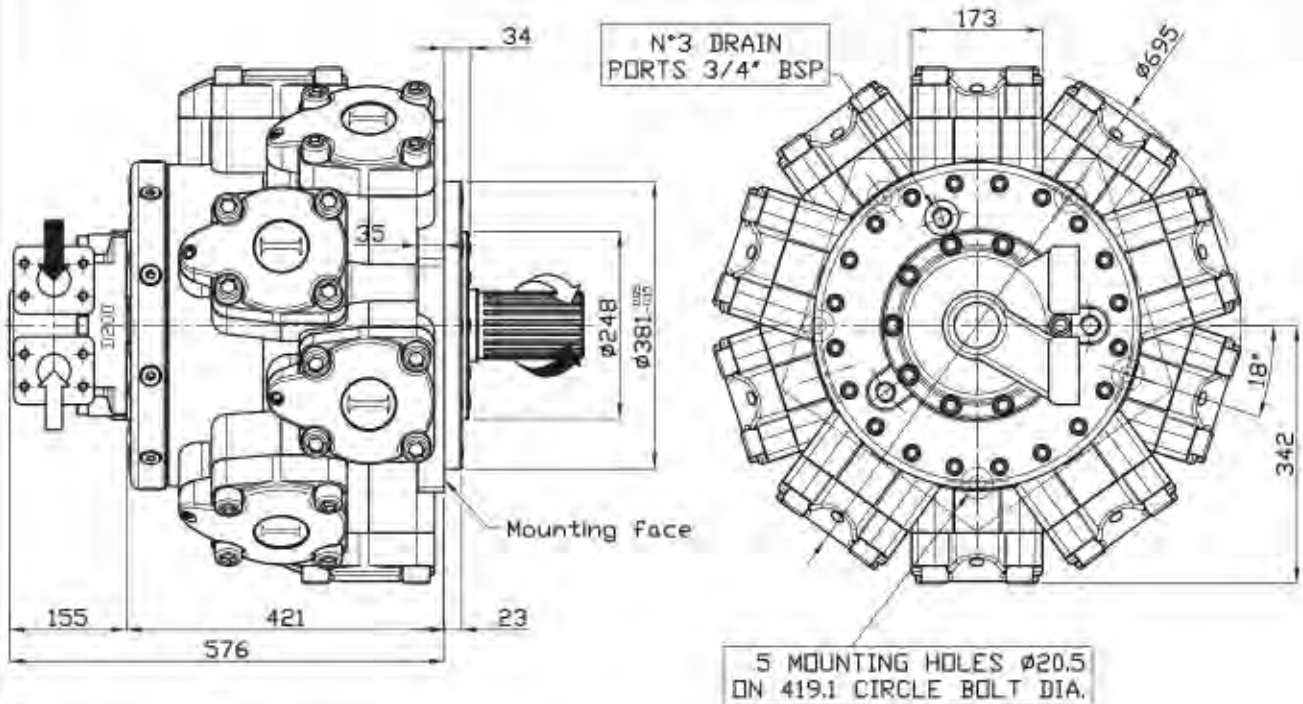

## SHAFT

### IAM 6000-6500-6800-7600-8000 H8

**A1:**  
Standard  
Splined Shaft

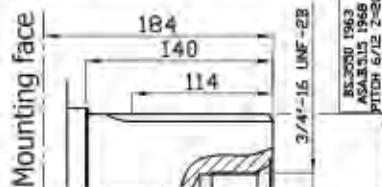

**A2:**  
Parallel Shaft  
on request

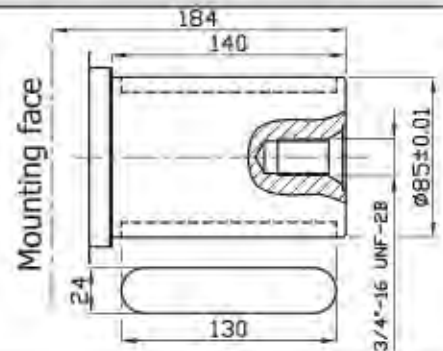

**A11:**  
Splined Shaft  
on request

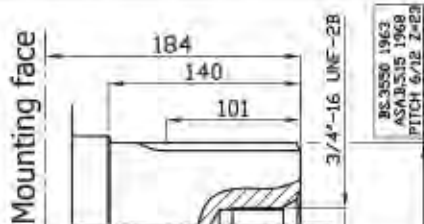

**A22:**  
Parallel Shaft  
on request

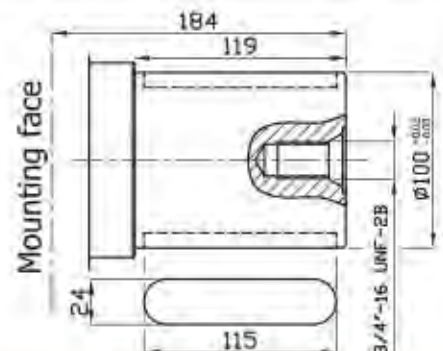

**A5:**  
Splined Shaft  
on request

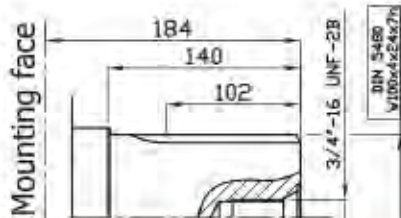



## SIZE

### IAM 6000/C-6500/C-6800/C-7600/C-8000/C H8

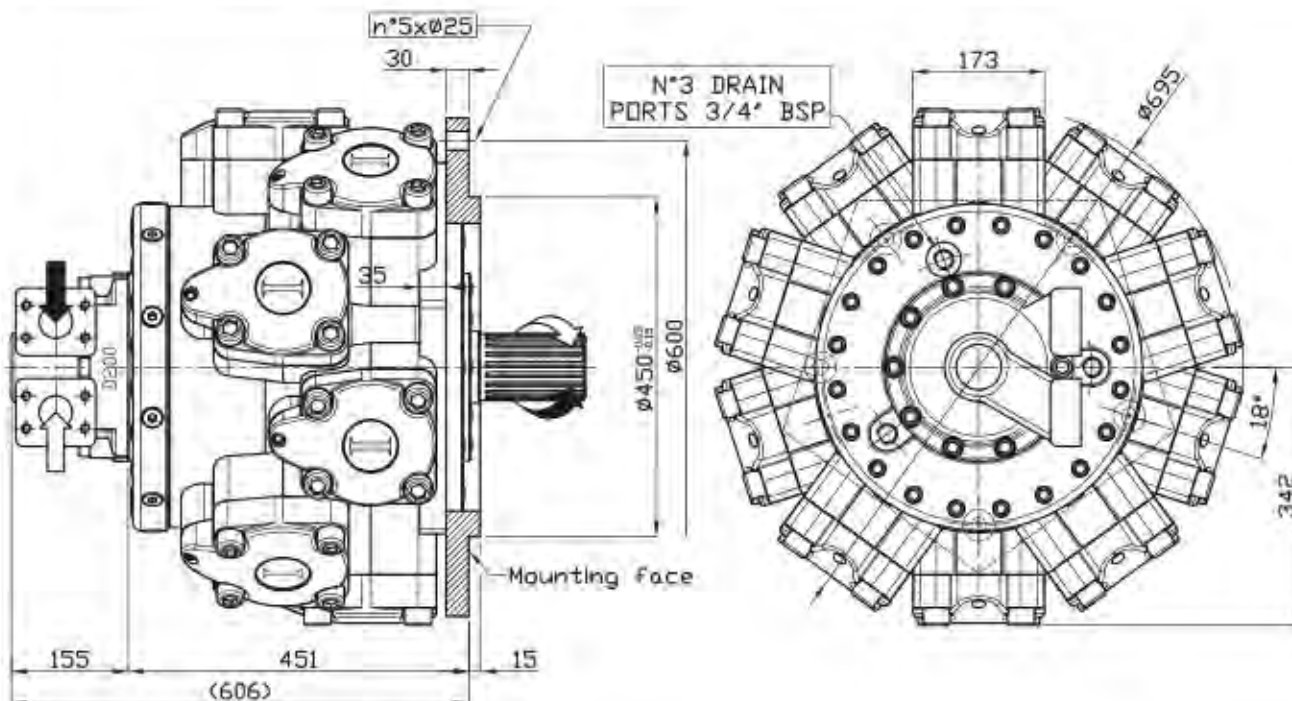

## SHAFT

### IAM 6000/C-6500/C-6800/C-7600/C-8000/C H8

A0: Standard splined shaft

A2: Parallel shaft on request

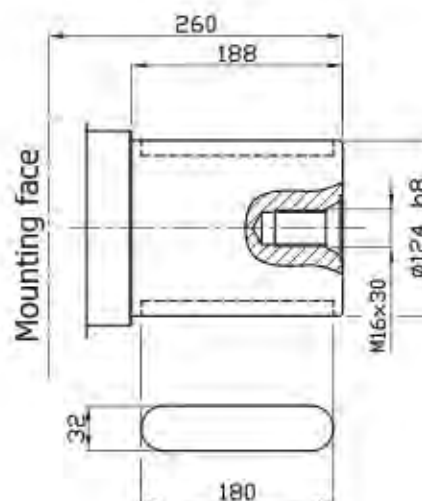
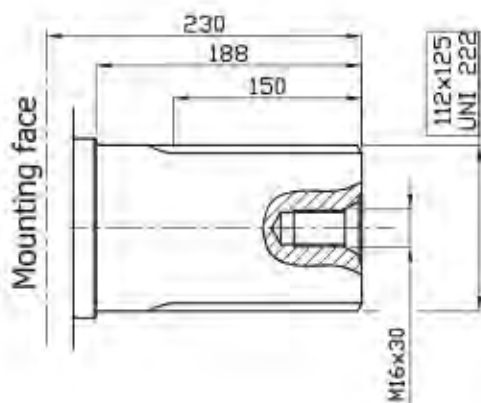



## ORDERING INSTRUCTIONS

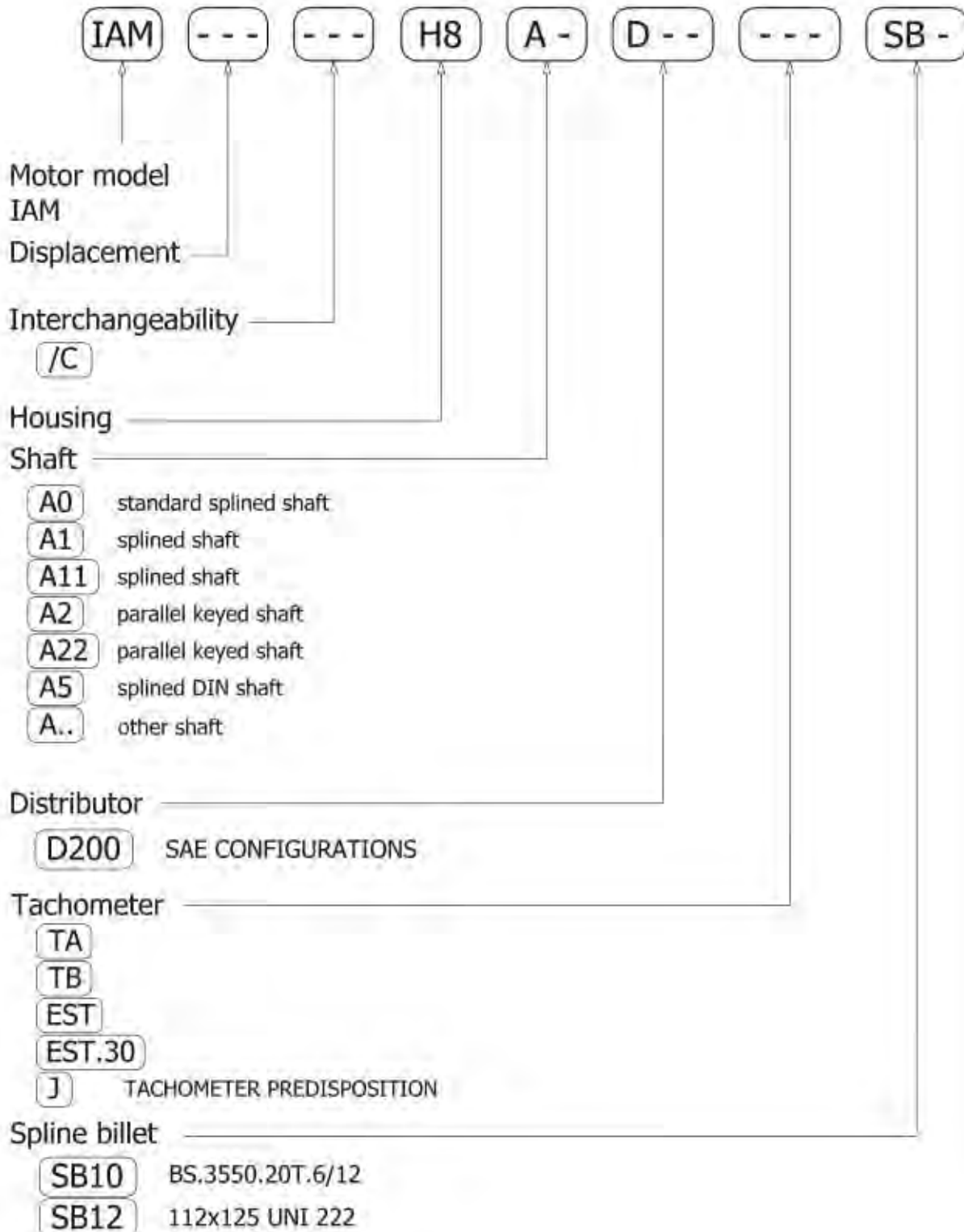

**EXAMPLE:** IAM.6000.H8.A1.D200  
IAM.6800.H8.A1.D200.TA.SB10  
IAM.8000/C.H8.A0.D200.J

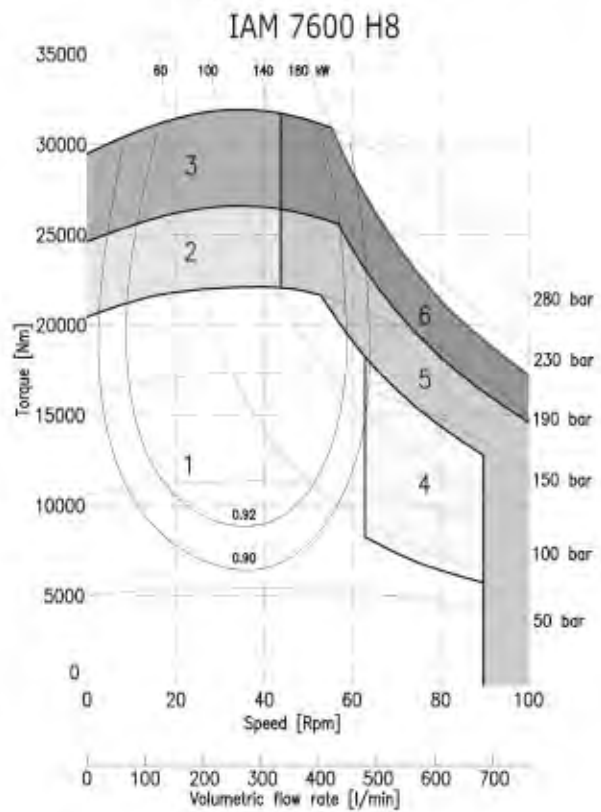
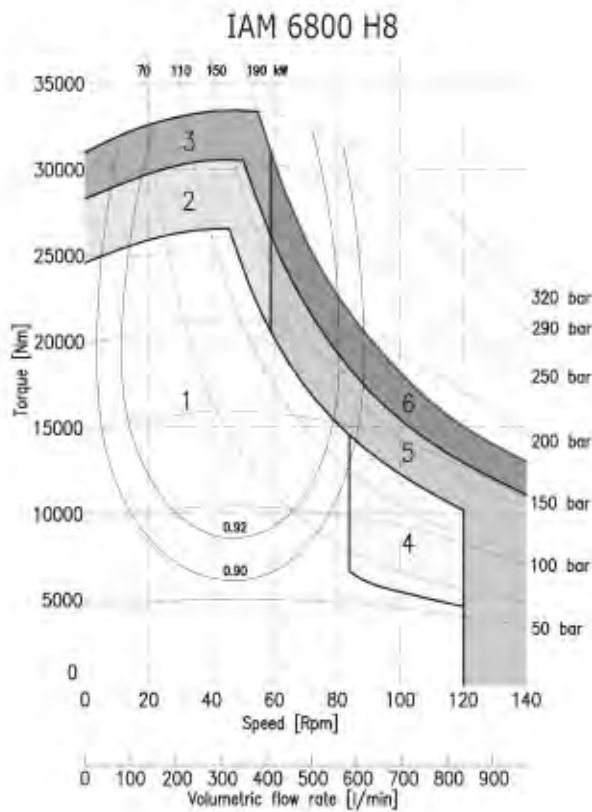
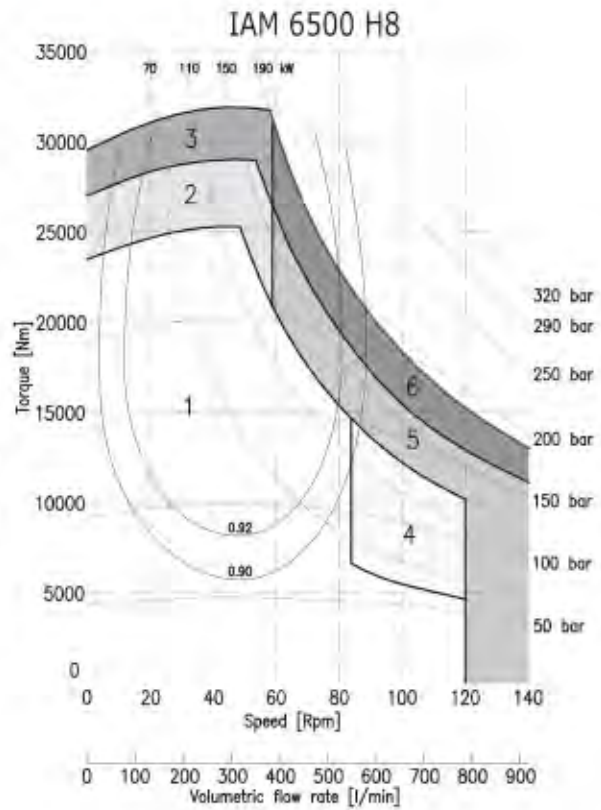
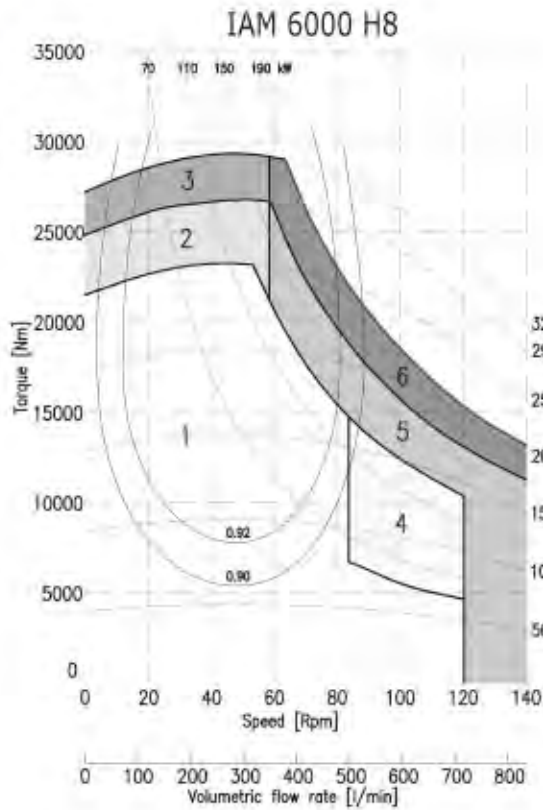

- 1 Continuous operation
- 2 Intermittent operation for period 3-5 minutes every 10-15 minutes
- 3 Intermittent operation for very short period (3-5 seconds) every 10-15 minutes

- 4 Continuous operation with flushing
- 5 Intermittent operation for period 3-5 minutes every 10-15 minutes with flushing
- 6 Intermittent operation for very short period (3-5 seconds) every 10-15 minutes with flushing

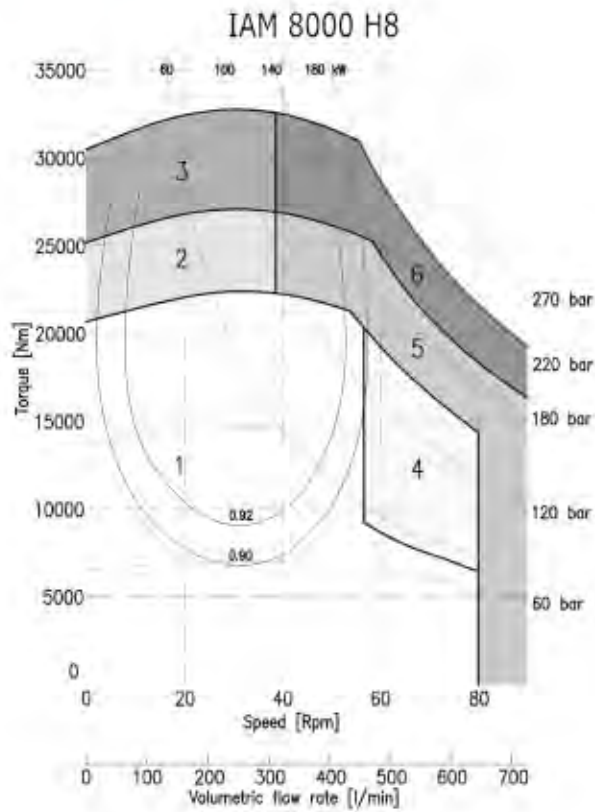

1	Continuous operation
2	Intermittent operation for period > 5 minutes every 10-15 minutes
3	Intermittent operation for very short period (> 5 seconds every 10-15 minutes)

4	Continuous operation with flaring
5	Intermittent operation for period > 5 minutes every 10-15 minutes with flaring
6	Intermittent operation for very short period (> 5 seconds every 10-15 minutes) with flaring





---

# ***ITALGROUP - ADVANCED - MOTORS FLOW DISTRIBUTORS***

---

***D31-D310-D40-D47-D55-  
D75-D90-D200***

---

## ***INDEX***

---

D31-D310-D40-D47	-----	<i>Pag.</i>	112
D55-D75-D90-D200	-----	"	113

## DISTRIBUTOR

### BSP CONFIGURATION

D31

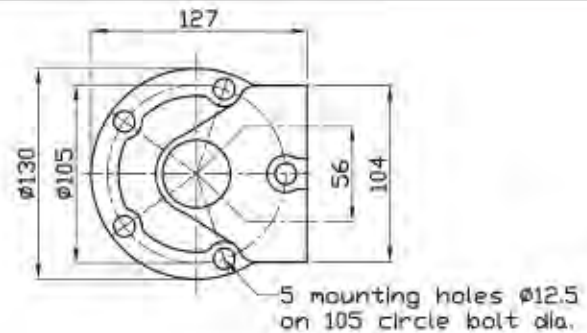
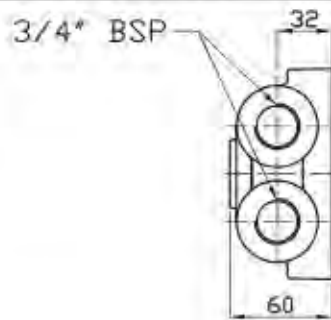

D310

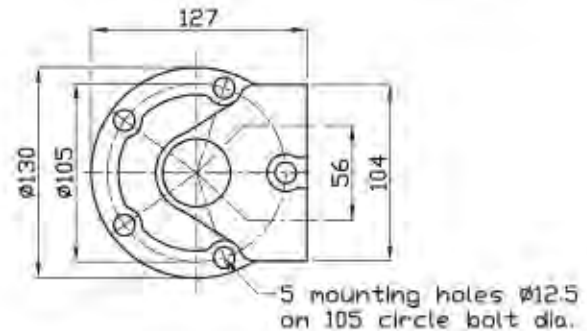
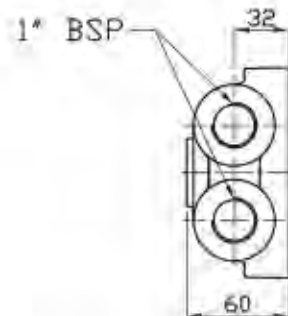

D40

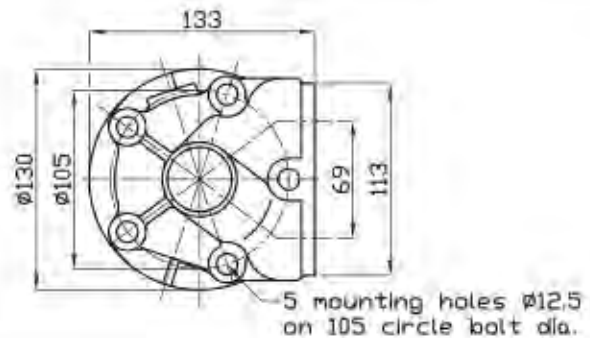
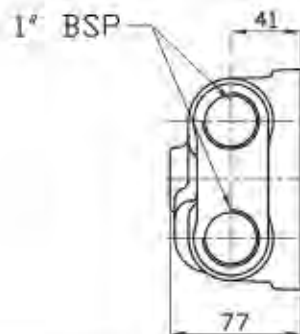

### SAE CONFIGURATION

D47

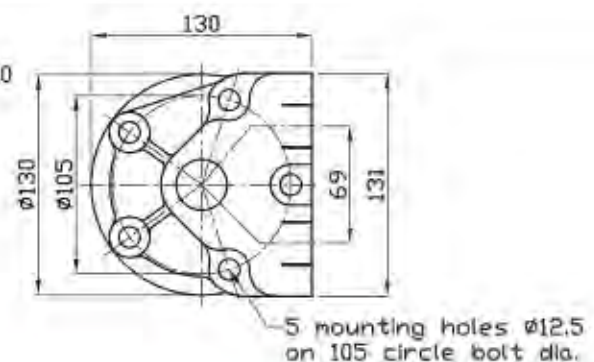
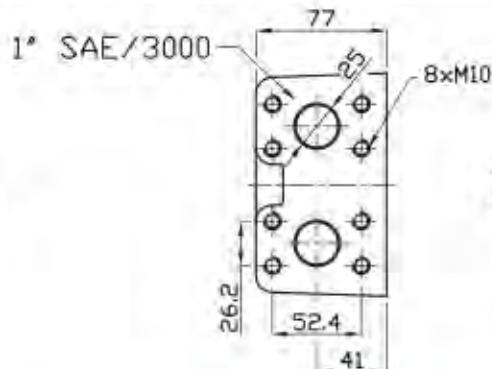



## SAE CONFIGURATION

D55

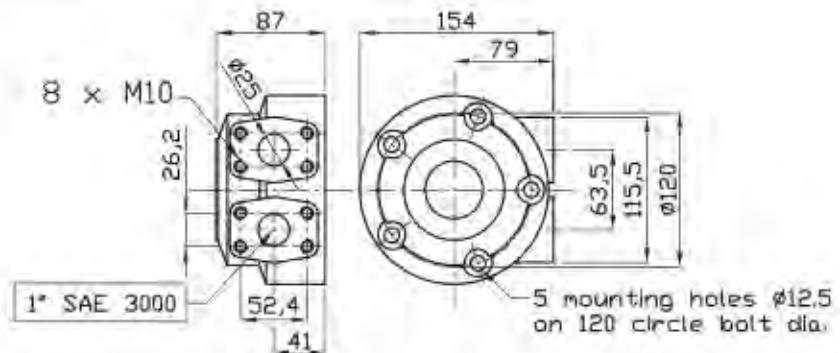

D75

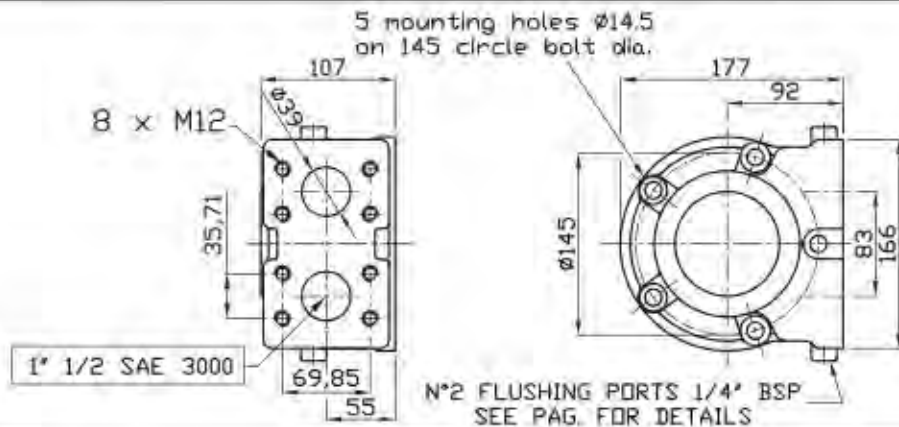

D90

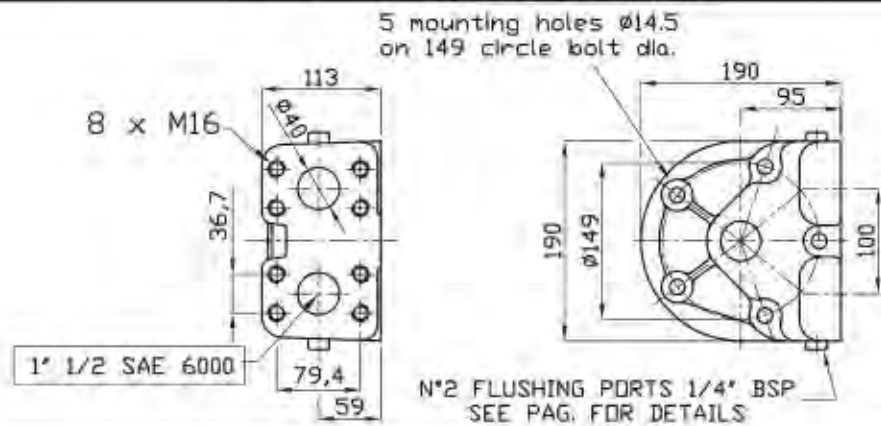

D200

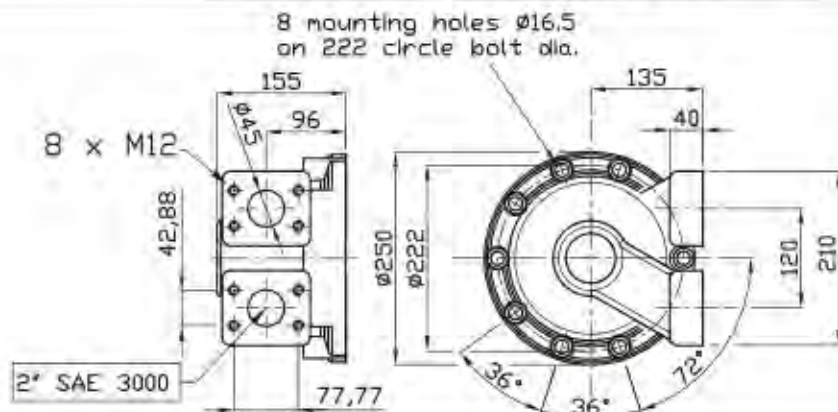



---

# ***ITALGROUP-ADVANCED-MOTORS***

---

## ***IAM SERIES***

---

## ***ACCESSORIES***

---

***VALVES:******RVDA SERIES******OVSA SERIES******OVDA SERIES******ORVSA SERIES******RVDAP SERIES******TACHOMETER******SPLINE BILLET******CONVERSION FLANGES***

---

### ***INDEX***

ITALGROUP VALVES GENERAL INFORMATION - - - - -	<i>Pag.</i>	117
RVDA SERIES – SIZE AND TECHNICAL DATA		
RVDA 80 - - - - -	"	118
RVDA 200 - - - - -	"	119
RVDA 380 - - - - -	"	120
OVSA SERIES – SIZE AND TECHNICAL DATA		
OVSA 160 - - - - -	"	121
OVSA 300 - - - - -	"	122
OVSA 480 - - - - -	"	123
OVDA SERIES – SIZE AND TECHNICAL DATA		
OVDA 160 - - - - -	"	124
OVDA 300 - - - - -	"	125



OVDA 480 - - - - -	"	126
ORVSA SERIES – SIZE AND TECHNICAL DATA		
OVSA 160 - - - - -	"	127
OVSA 300 - - - - -	"	128
OVSA 480 - - - - -	"	129
RVDAP SERIES – SIZE AND TECHNICAL DATA		
RVDAP 80 - - - - -	"	130
VALVES ORDERING INSTRUCTIONS - - - - -	"	131
TACHOMETER - - - - -	"	132
SPLINE BILLET - - - - -	"	133
CONVERSION FLANGES - - - - -	"	135

## **ITALGROUP VALVES GENERAL INFORMATION**

ITALGROUP can supply a wide range of flangeable valves, that can be easily mounted on ITALGROUP hydraulic motors.

### **OVERCENTER VALVE**

The overcenter valves are required when static and dynamic control is needed.

#### Single overcenter valve



The single overcenter valve (OVSA) is used for unidirectional loads. The single overcenter valve can be supplied with an integrated relief valve too (ORVSA serie).

#### Dual overcenter valve



The dual overcenter valve (OVDA) is used for bidirectional loads.

### **DUAL RELIEF VALVE**



The dual cross over relief valve (RVDA) is used to avoid motor pressure peaks. The maximum pressure can be set adjusting the relief valve screw. The dual cross relief valve can be supplied with an integrated flushing valve (RVDAP serie).

On request, the RVDA valves can be mounted together with OVSA or OVDA valves. For further details please contact Italgrou S.r.l. technical department.

## SIZE AND TECHNICAL DATA

**RVDA 80**

**RVDA SERIES**

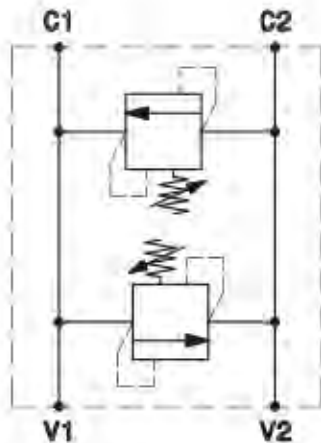
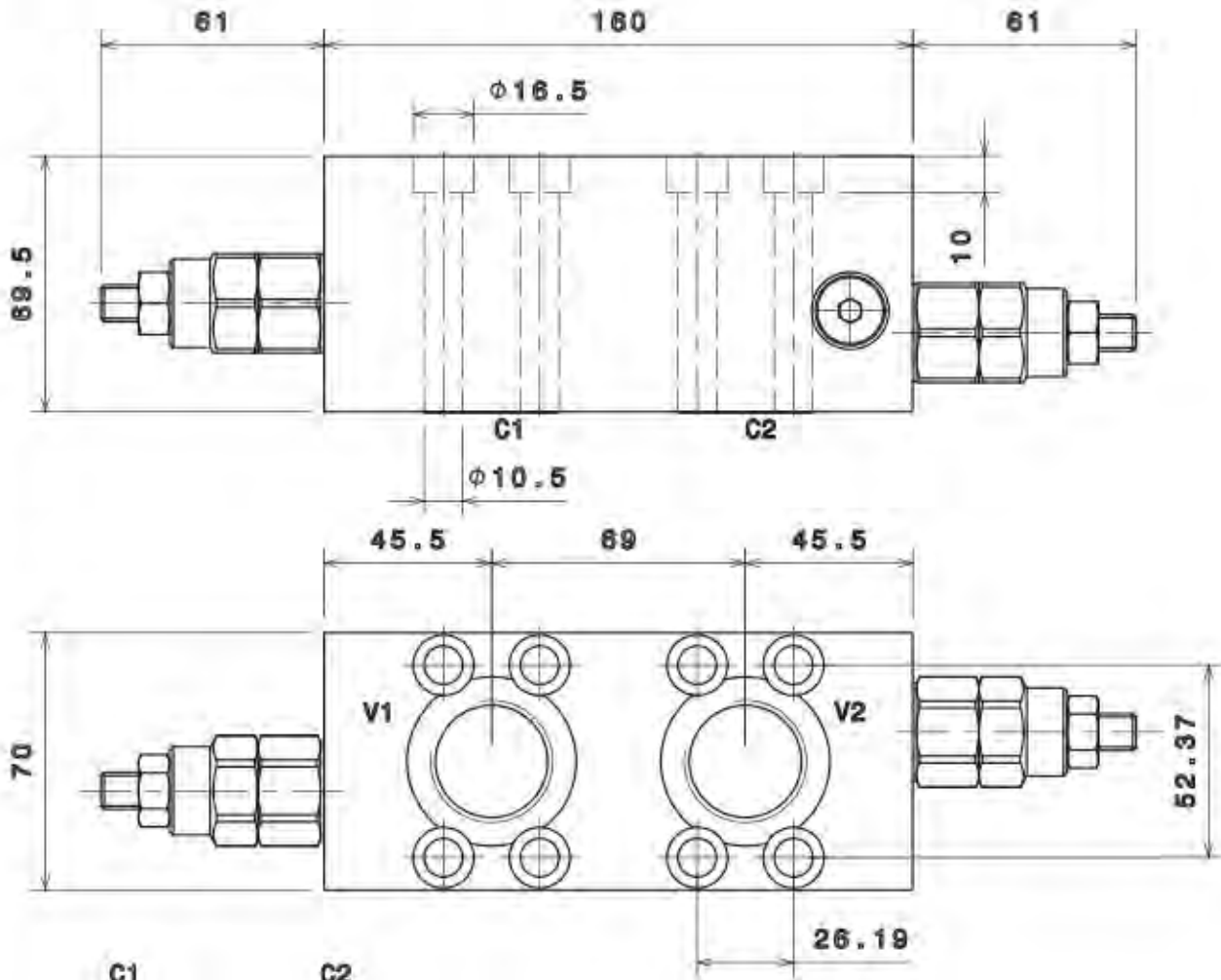

PORTS DIMENSION	
V1,V2	1" BSPP
C1,C2	O-ring 2-125

### TECHNICAL DATA

Material	Anodized aluminium corrosion resistant
Maximum pressure	300 bar
Maximum flow rate	80 l/min
Relief valve setting range	A 20-100 bar standard setting 80 bar
	B 40-250 bar standard setting 180 bar
	C 60-350 bar standard setting 250 bar

Italgrou distributor fitting

**D47**



## SIZE AND TECHNICAL DATA

RVDA 200

RVDA SERIES

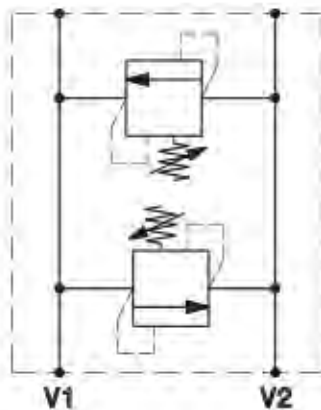
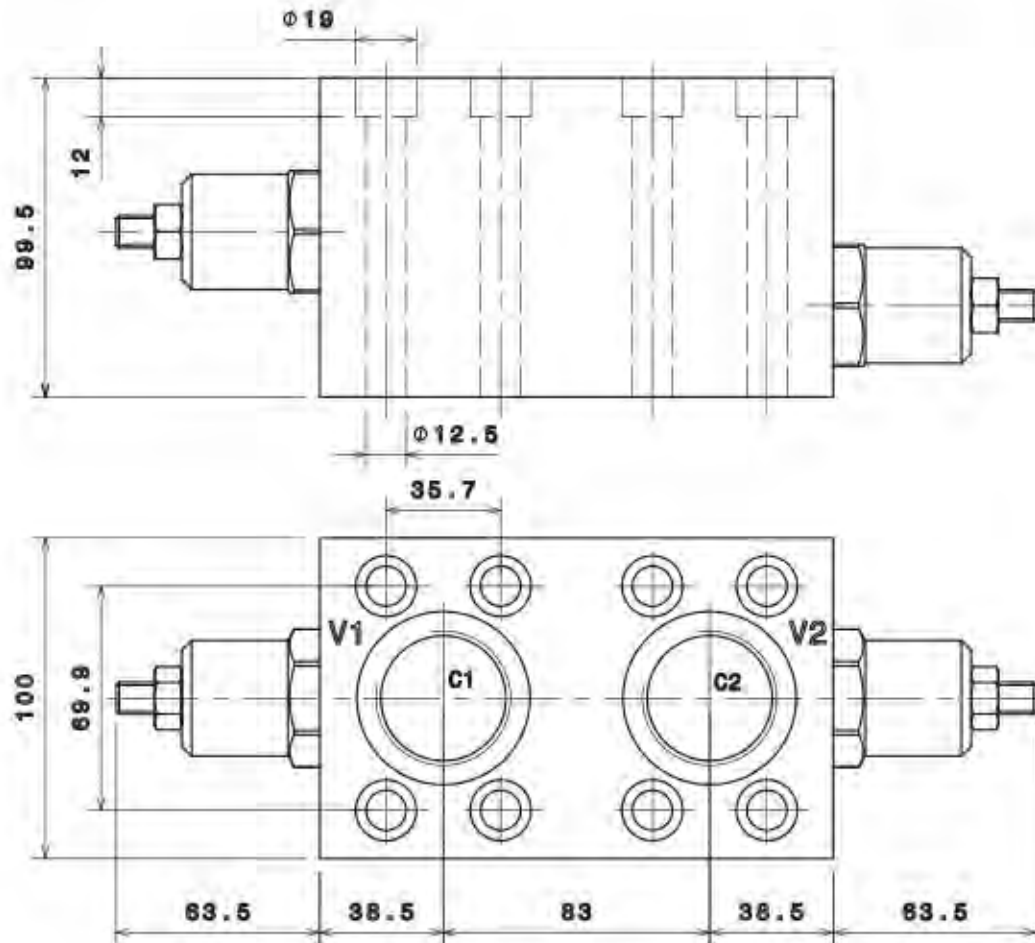

PORTS DIMENSION	
V1,V2	1"1/4 BSPP
C1,C2	O-Ring 2-224

TECHNICAL DATA	
Material	Anodized aluminium corrosion resistant
Maximum pressure	300 bar
Maximum flow rate	200 l/min
Relief valve setting range	A 20-100 bar standard setting 80 bar
	B 40-250 bar standard setting 180 bar
	C 60-350 bar standard setting 250 bar

Italgrou distributor fitting

**D75**

## SIZE AND TECHNICAL DATA

**RVDA 380**

**RVDA SERIES**

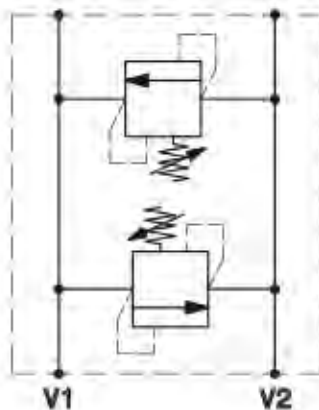
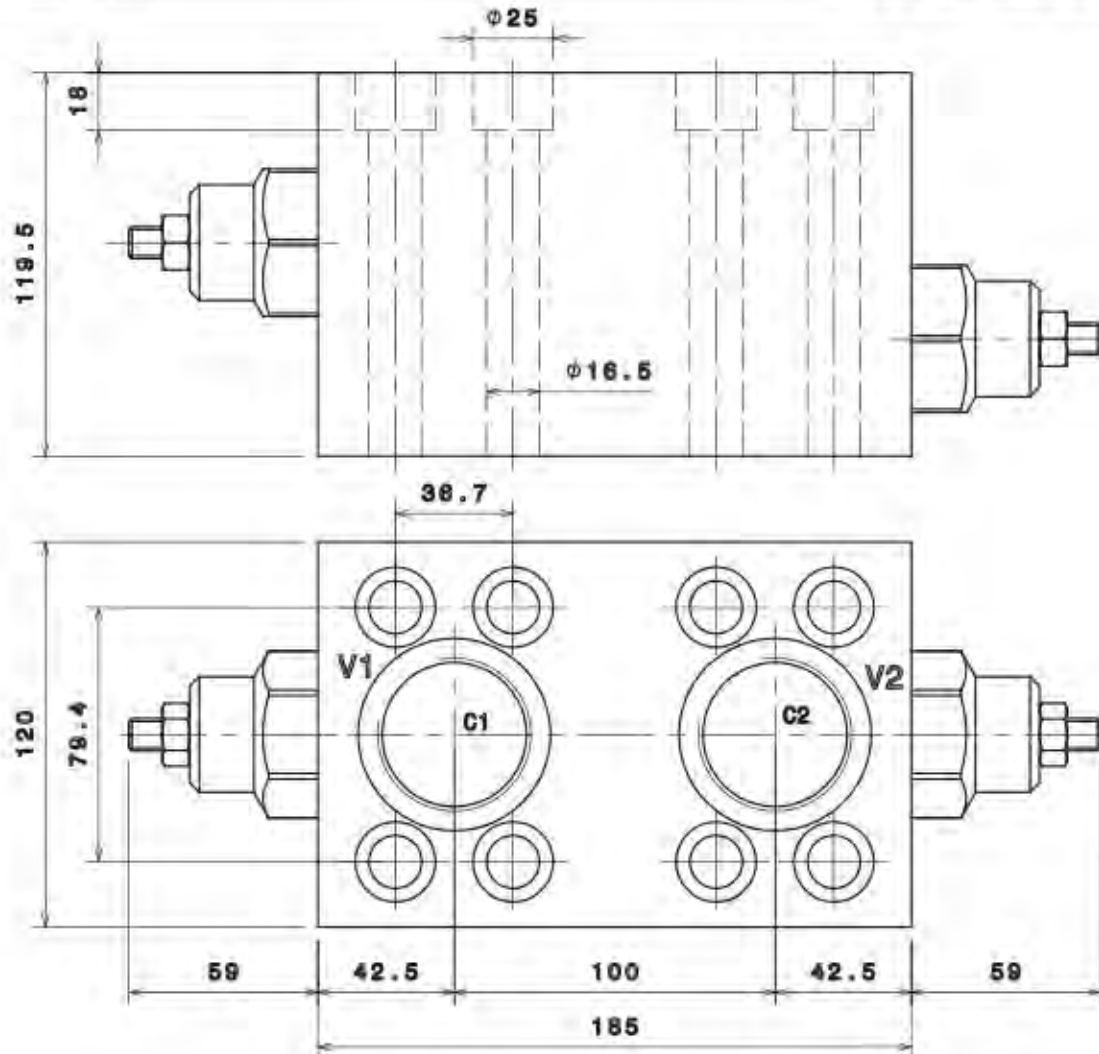

PORTS DIMENSION	
V1,V2	1"1/2 BSPP
C1,C2	O-Ring 2-225

TECHNICAL DATA	
Material	Anodized aluminium corrosion resistant
Maximum pressure	300 bar
Maximum flow rate	380 l/min
Relief valve setting range	A
	20-100 bar standard setting 80 bar
	B
40-250 bar standard setting 180 bar	
C	
60-350 bar standard setting 250 bar	

Italgrou distributor fitting

**D90**





## SIZE AND TECHNICAL DATA

OVSA 300

OVSA SERIES

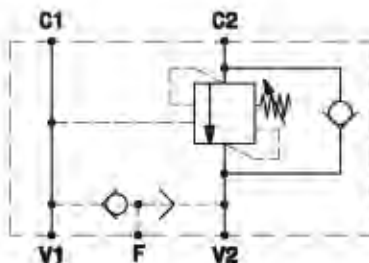
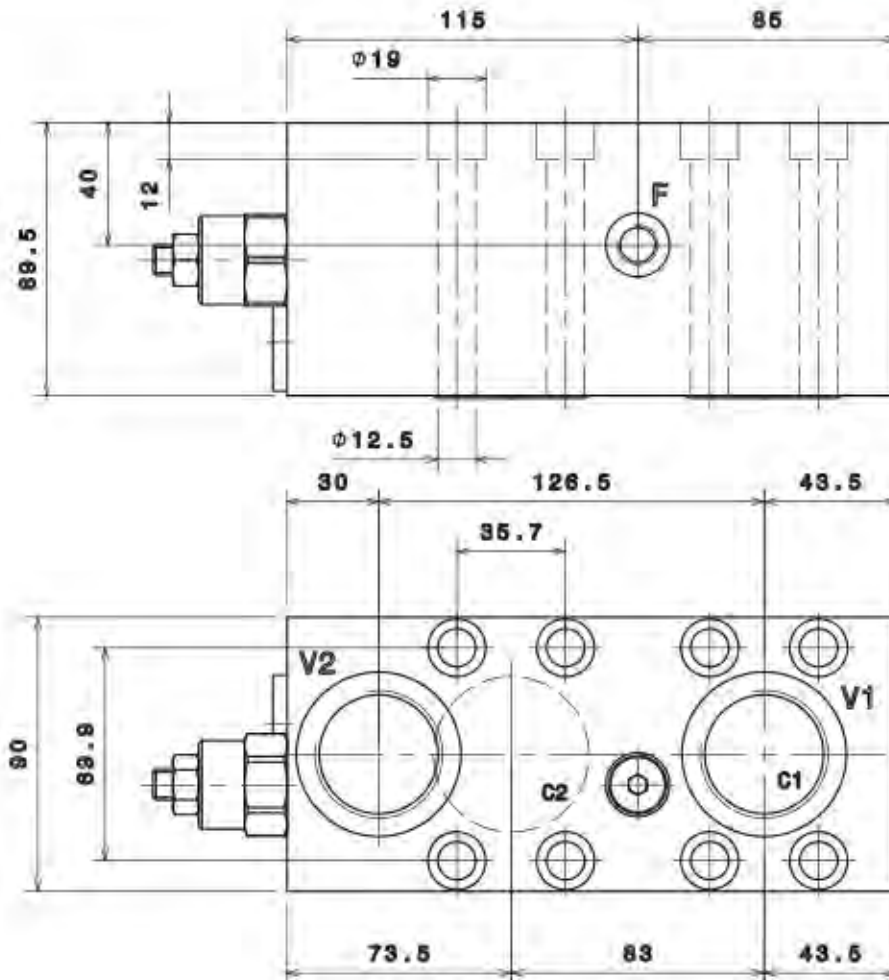

PORTS DIMENSION	
V1,V2	1"1/4 BSPP
C1,C2	O-Ring 2-224
F	1/4" BSPP

TECHNICAL DATA		
Material	Anodized aluminium corrosion resistant	
Peak pressure	350 bar	
Maximum pressure	300 bar	
Maximum flow rate	300 l/min	
Pilot ratio	1	3:1
	2	4.25:1
	3	8:1
	4	10:1
Relief valve setting range	A	20-200 bar standard setting 100 bar
	B	50-350 bar standard setting 280 bar

Italgrou distributor fitting

**D75**

## SIZE AND TECHNICAL DATA

OVSA 480

OVSA SERIES

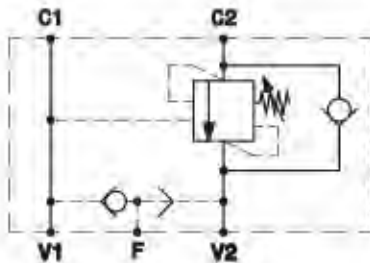
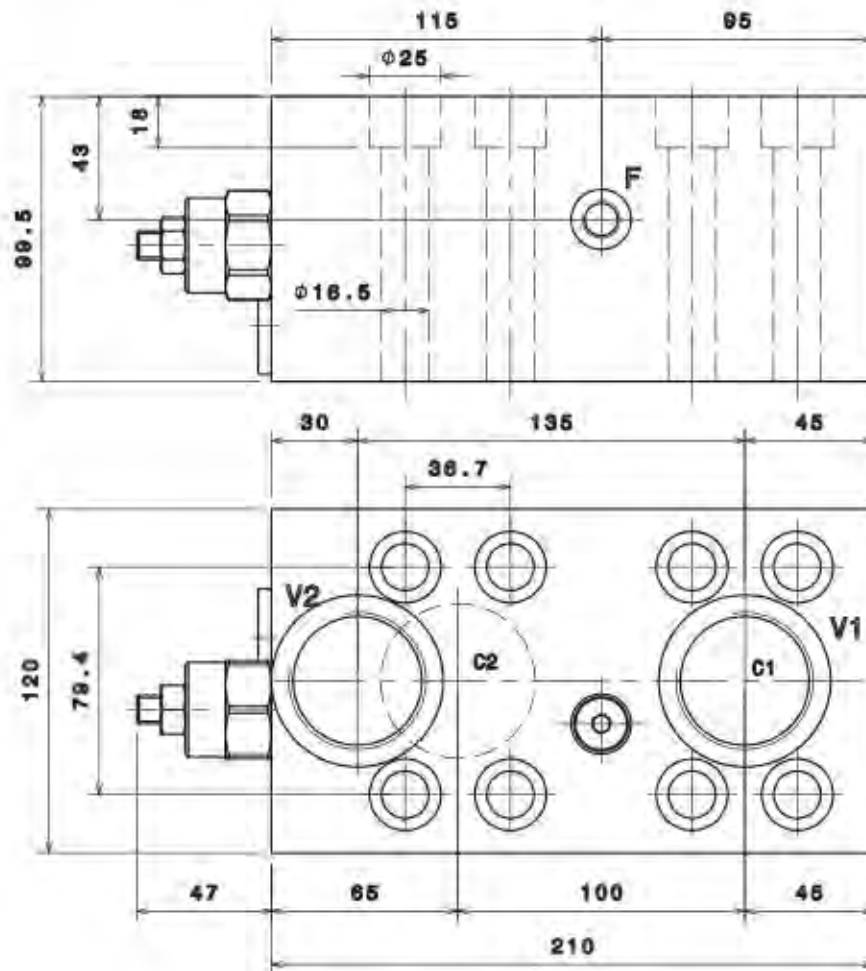

PORTS DIMENSION	
V1,V2	1"1/2 BSPP
C1,C2	O-Ring 2-225
F	1/4" BSPP

TECHNICAL DATA	
Material	Anodized aluminium corrosion resistant
Peak pressure	350 bar
Maximum pressure	300 bar
Maximum flow rate	480 l/min
Pilot ratio	1 3:1
	2 4.25:1
	3 8:1
	4 10:1
Relief valve setting range	A 20-200 bar standard setting 100 bar
	B 50-350 bar standard setting 280 bar

Italgrou distributor fitting

D90

## SIZE AND TECHNICAL DATA

OVDA 160

OVDA SERIES

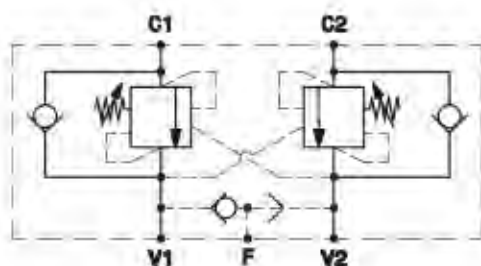
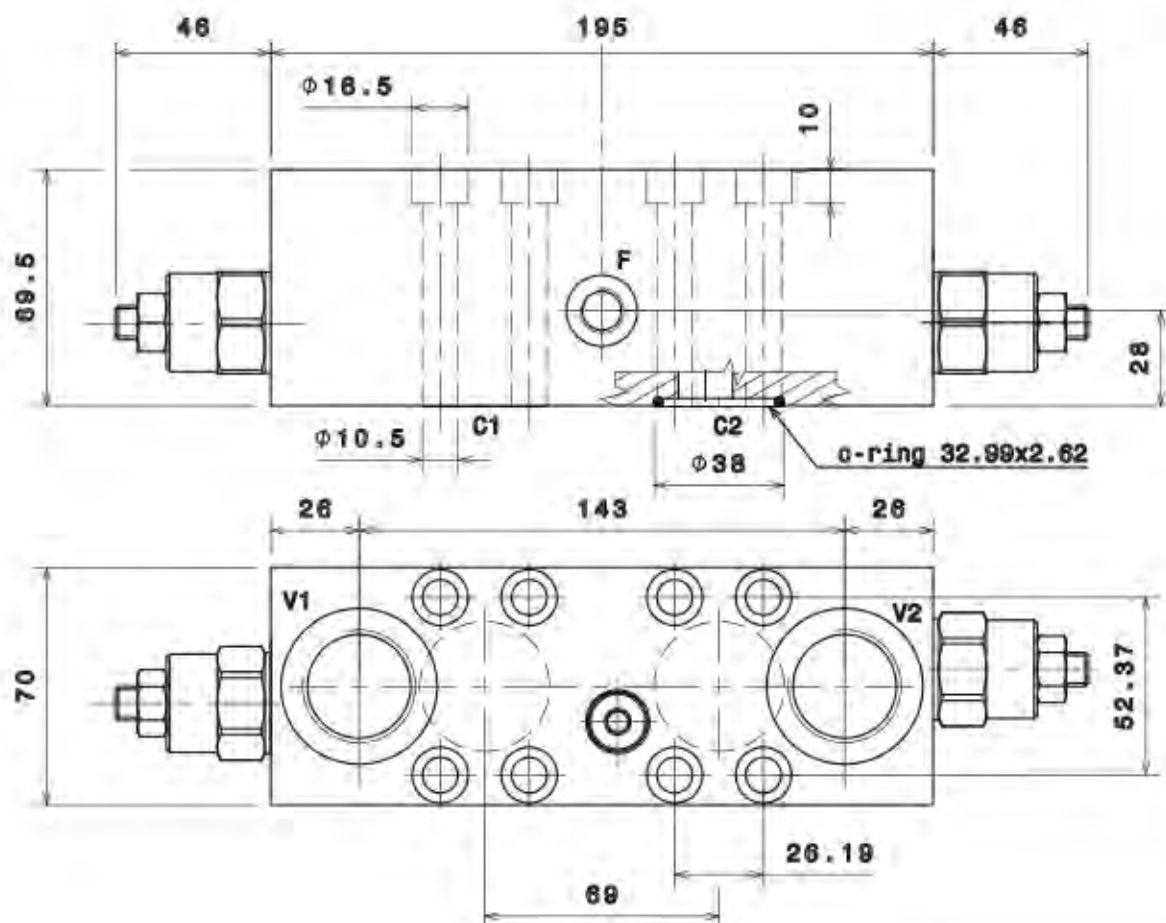

PORTS DIMENSION	
V1,V2	1" BSPP
C1,C2	O-ring 2-125
F	1/4" BSPP

### TECHNICAL DATA

Material	Anodized aluminium corrosion resistant	
Peak pressure	350 bar	
Maximum pressure	270 bar	
Maximum flow rate	150 l/min	
Pilot ratio	1	3:1
	2	4.25:1
	3	8:1
	4	10:1
Relief valve setting range	A	20-200 bar standard setting 100 bar
	B	50-350 bar standard setting 280 bar

Italgrou distributor fitting

**D47**



## SIZE AND TECHNICAL DATA

OVDA 300

OVDA SERIES

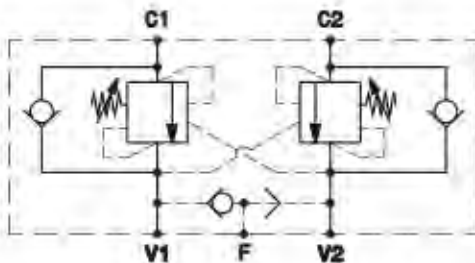
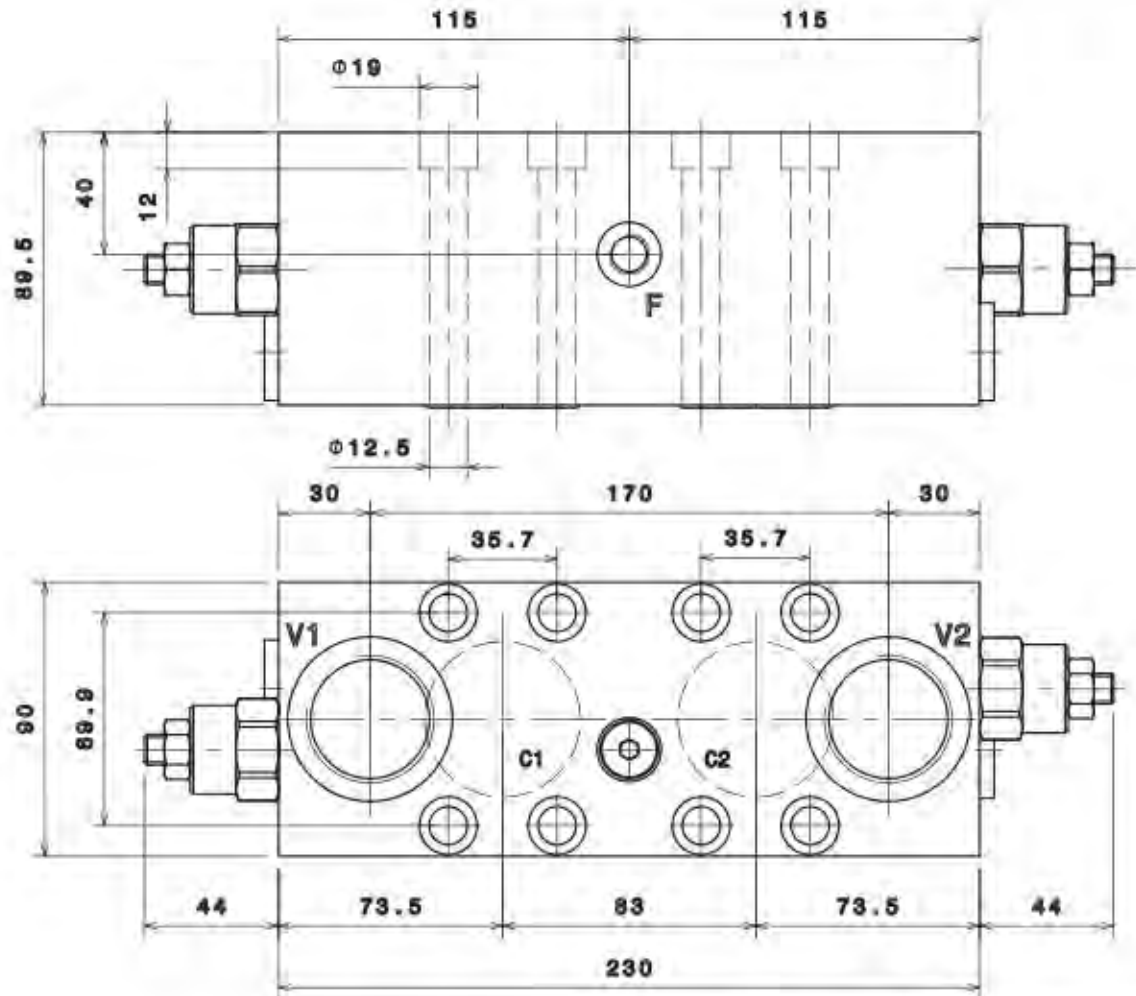

PORTS DIMENSION	
V1,V2	1"1/4 BSPP
C1,C2	O-Ring 2-224
F	1/4" BSPP

### TECHNICAL DATA

Material	Anodized aluminium corrosion resistant	
Peak pressure	350 bar	
Maximum pressure	300 bar	
Maximum flow rate	300 l/min	
Pilot ratio	1	3:1
	2	4.25:1
	3	8:1
	4	10:1
Relief valve setting range	A	20-200 bar standard setting 100 bar
	B	50-350 bar standard setting 280 bar

Italgrou distributor fitting

D75



## SIZE AND TECHNICAL DATA

ORVSA 160

ORVSA SERIES

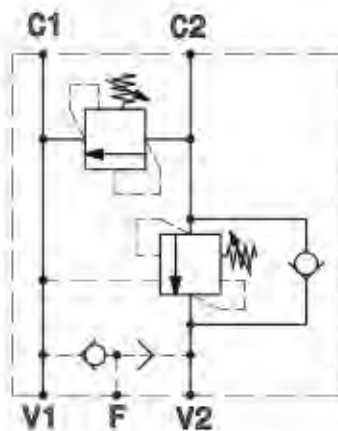
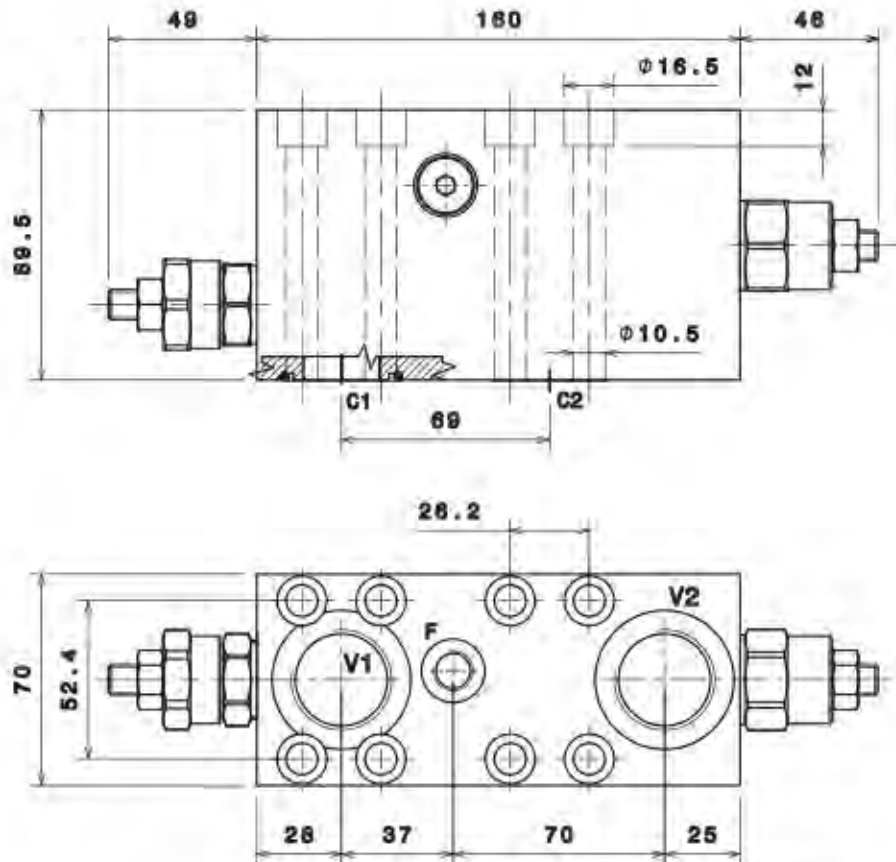

PORTS DIMENSION	
V1,V2	1" BSPP
C1,C2	O-Ring 2-126
F	1/4" BSPP

TECHNICAL DATA	
Material	Anodized aluminium corrosion resistant
Peak pressure	350 bar
Maximum pressure	300 bar
Maximum flow rate	150 l/min
Pilot ratio	1 3:1
	2 4.25:1
	3 8:1
	4 10:1
OVC relief valve setting range	A 20-200 bar standard setting 100 bar
	B 50-350 bar standard setting 280 bar
VLP relief valve setting range	A 20-100 bar standard setting 80 bar
	B 40-250 bar standard setting 180 bar
	C 60-350 bar standard setting 250 bar

Italgrou distributor fitting

D47



## SIZE AND TECHNICAL DATA

ORVSA 300

ORVSA SERIES

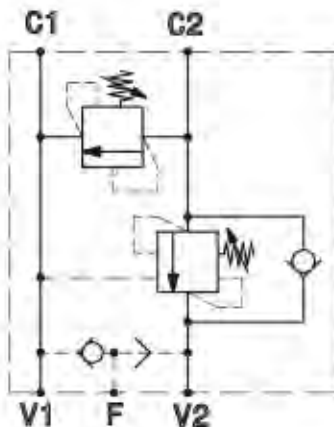
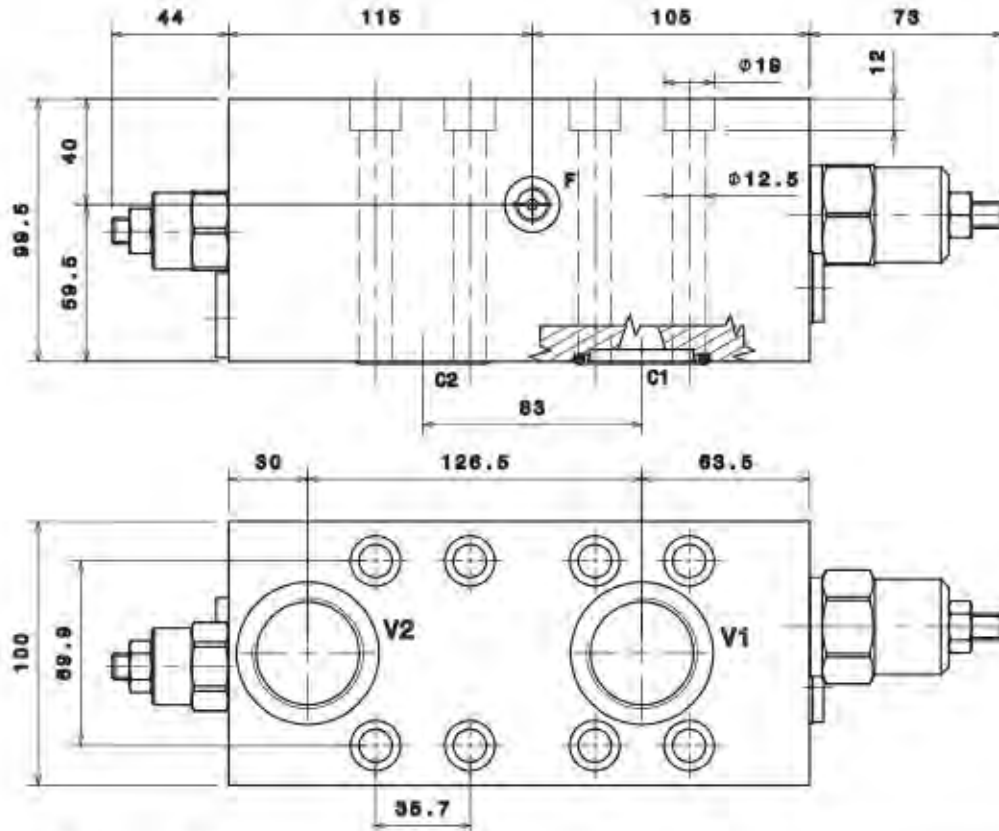

PORTS DIMENSION	
V1,V2	1"1/4" BSPP
C1,C2	O-Ring 2-224
F	1/4" BSPP

TECHNICAL DATA	
Material	Anodized aluminium corrosion resistant
Peak pressure	350 bar
Maximum pressure	300 bar
Maximum flow rate	300 l/min
Pilot ratio	1 3:1
	2 4.25:1
	3 8:1
	4 10:1
OVC relief valve setting range	A 20-200 bar standard setting 100 bar
	B 50-350 bar standard setting 280 bar
VLP relief valve setting range	A 20-100 bar standard setting 80 bar
	B 40-250 bar standard setting 180 bar
	C 60-350 bar standard setting 250 bar

Italgrou distributor fitting

D75

## SIZE AND TECHNICAL DATA

ORVSA 480

ORVSA SERIES

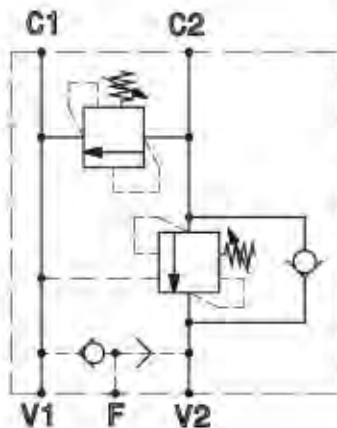
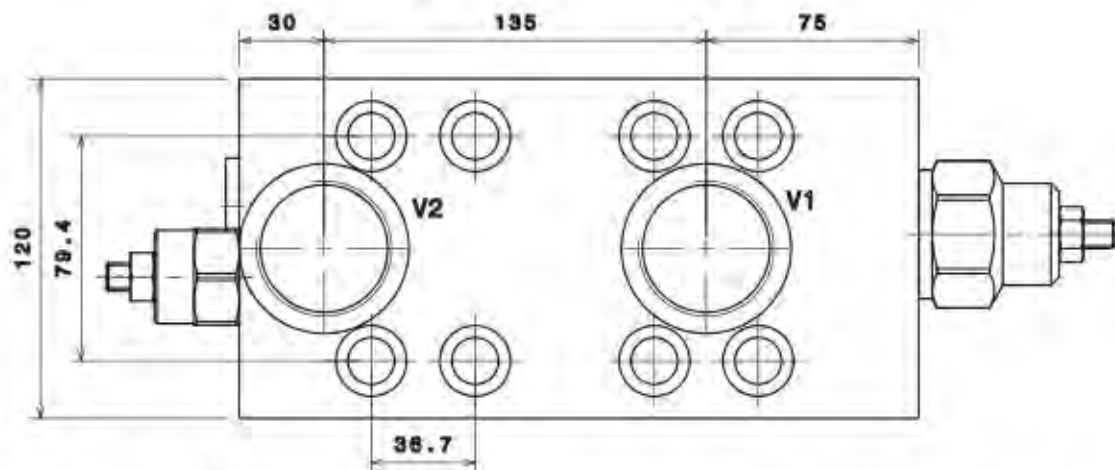
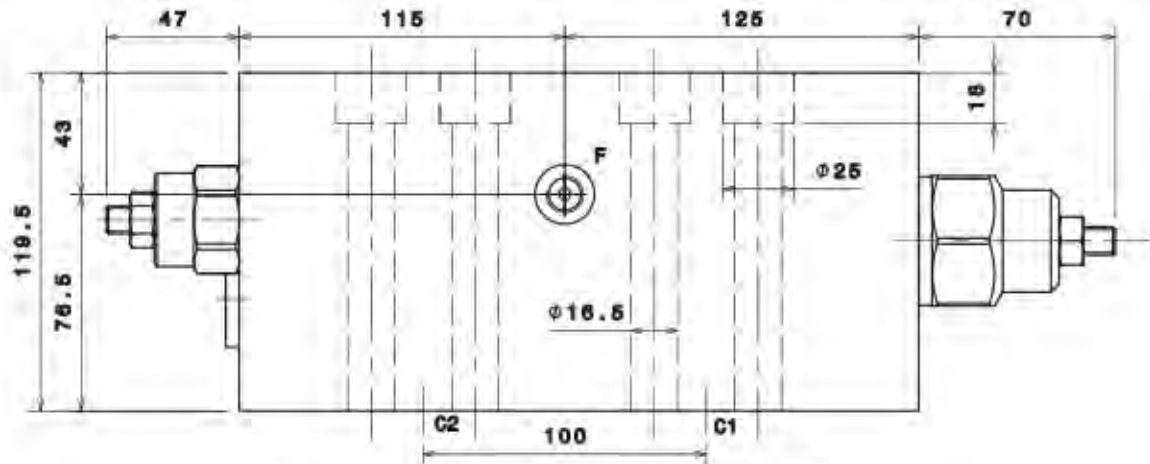

PORTS DIMENSION	
V1,V2	1 1/2" BSPP
C1,C2	O-Ring 2-225
F	1/4" BSPP

TECHNICAL DATA	
Material	Anodized aluminium corrosion resistant
Peak pressure	350 bar
Maximum pressure	300 bar
Maximum flow rate	480 l/min
Pilot ratio	1 3:1
	2 4.25:1
	3 8:1
OVC relief valve setting range	A 20-200 bar standard setting 100 bar
	B 50-350 bar standard setting 280 bar
	C 60-350 bar standard setting 250 bar
VLP relief valve setting range	A 20-100 bar standard setting 80 bar
	B 40-250 bar standard setting 180 bar
	C 60-350 bar standard setting 250 bar

Italgrou distributor fitting

D90

## SIZE AND TECHNICAL DATA

RVDAP 80

RVDAP SERIES

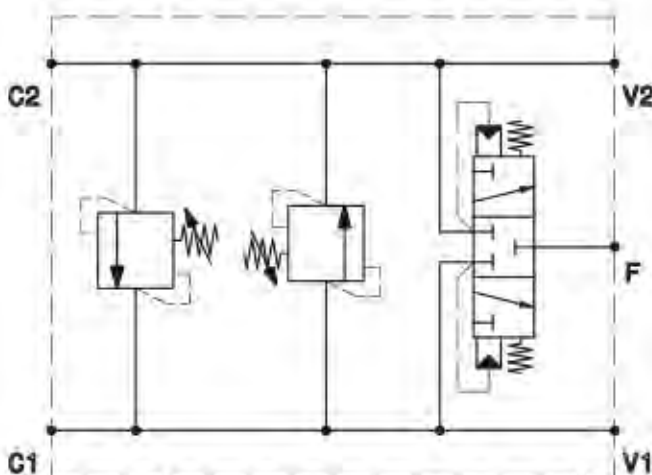
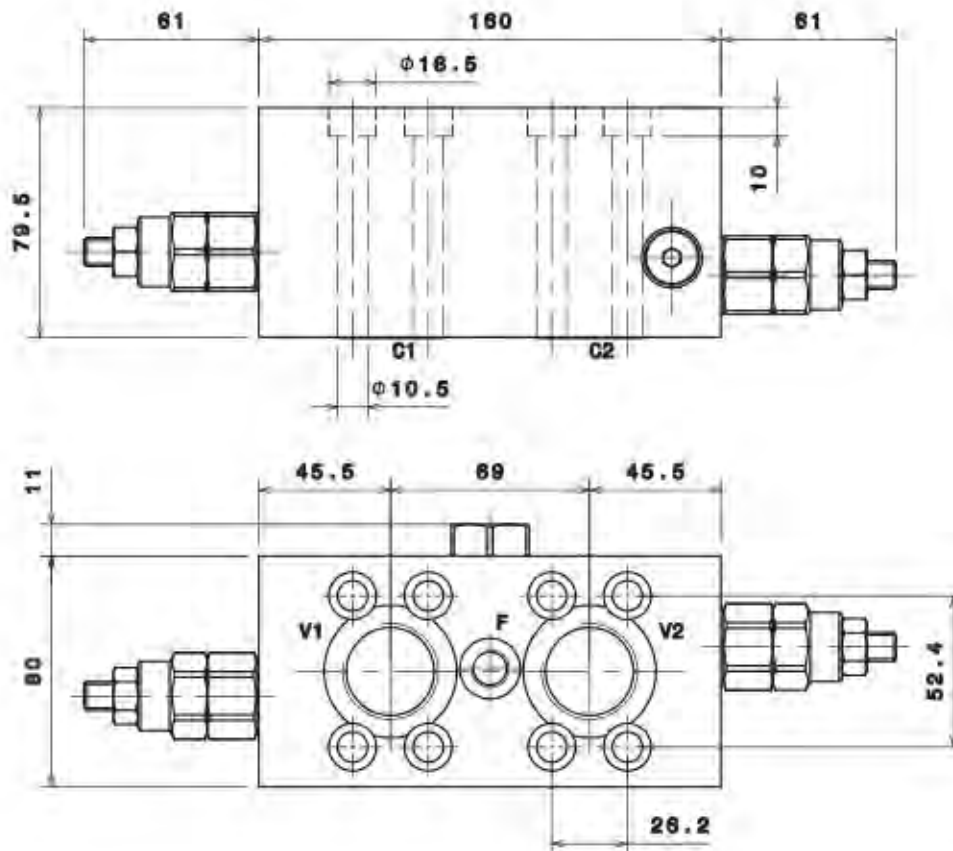

TECHNICAL DATA	
Material	Anodized aluminium corrosion resistant
Maximum pressure	300 bar
Maximum flow rate	80 l/min
Relief valve setting range	A
	20-100 bar standard setting 80 bar
	B
40-250 bar standard setting 180 bar	
C	
60-350 bar standard setting 250 bar	

PORTS DIMENSION	
V1,V2	1" BSPP
C1,C2	O-Ring 2-125
F	1/4" BSPP

Italgrou distributor fitting

D47



# ORDERING INSTRUCTIONS

# VALVES

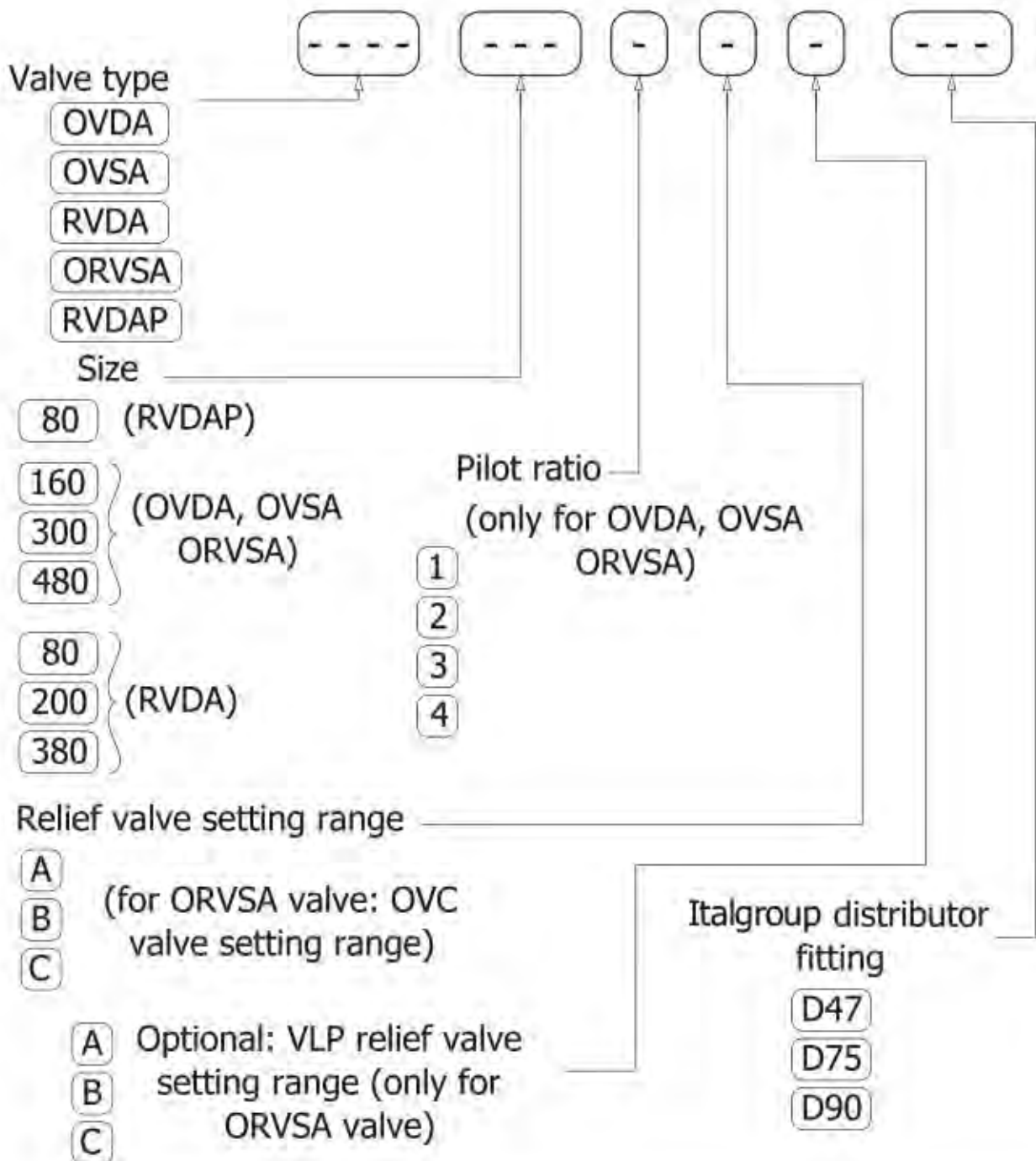

**EXAMPLE:** OVDA.300.1.A.D75  
RVDA.200.C.D75  
OVSA.160.2.B.D47  
OVDA.480.1.A.D90  
ORVSA.160.3.A.B.D47  
RVDAP.80.B.D47

The data specified into the catalogue are for product description purpose only and must not be interpreted as warranted characteristics in legal sense. Italgroup S.r.l. reserves the right to implement modifications without notice. All partial or total reproduction and copy without written authorization of Italgroup S.r.l. is strictly forbidden.

## TACHOMETER

TA

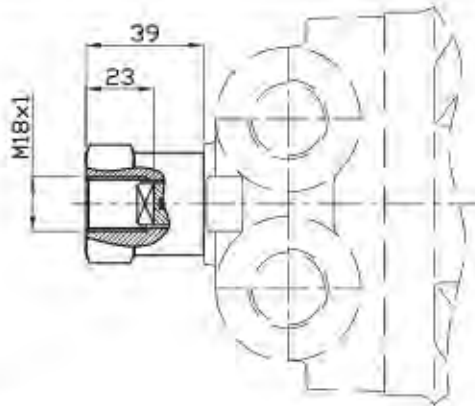

TB

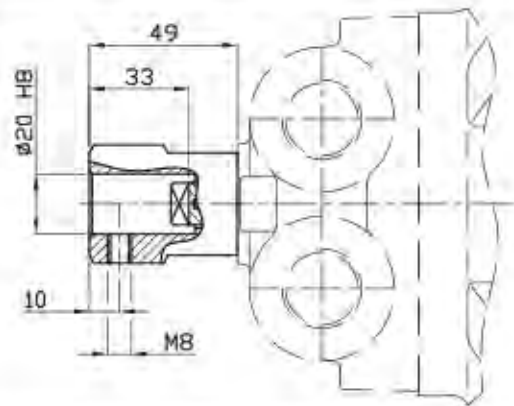

EST

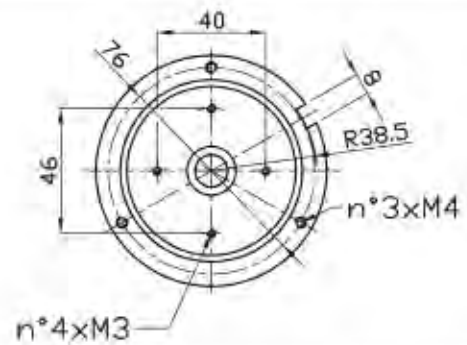
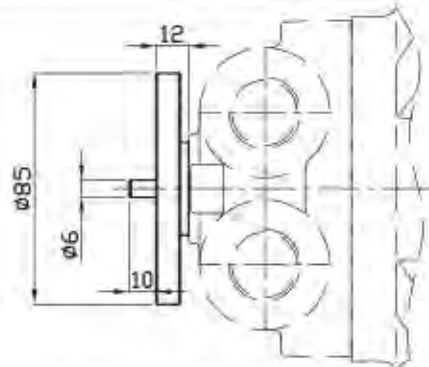

EST.30

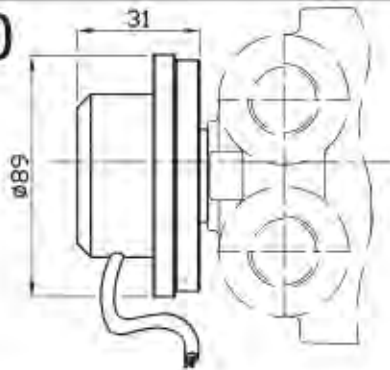

Operating parameters	E-.../3
Power supply (VDC)	10-30
Switching current (mA)	150
Frequency (Hz) 100rpm	50
Impulse/rpm	30
Operating temp. (°C)	-24/+70
Protection degree	IP67
Output	NPN
Motor type	All types

MODEL	Ø5
Torque	1 Nm

Model	Output	Fig.
E-.../...AP/...	PNP	D

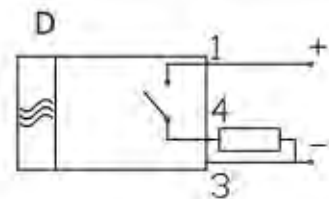

# SPLINE BILLET

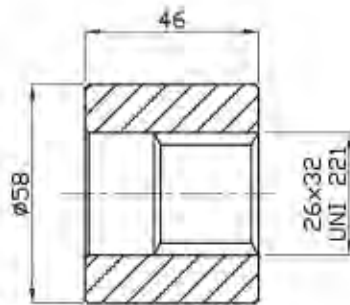
**SB1**

only for:

 IAM 80, 100, 150,175,195 H1 A0  
 IAM 80, 100, 150,175,195 H1 A1

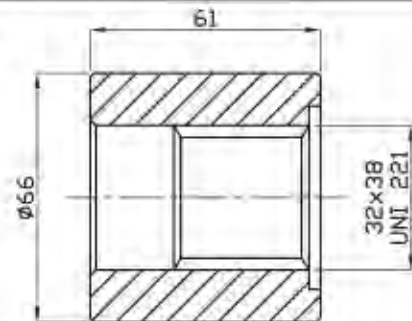
**SB2**

only for:

 IAM 200,250,300 H1 A0  
 IAM 200,250,300,350 H2 A0  
 IAM 190/C H2 A0

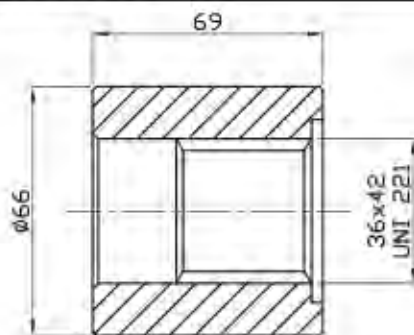
**SB3**

only for:

 IAM 400,500,600 H2 A0  
 IAM 400,450,500,600,650,700 H3 A0

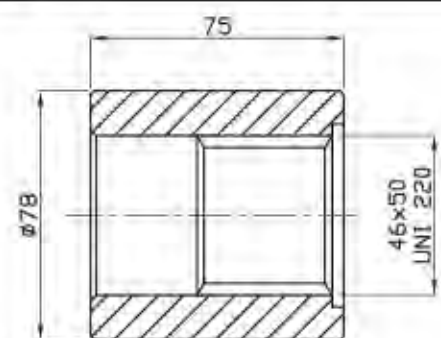
**SB4**

only for:

 IAM 800 H3 A0  
 IAM 800/N H3 A0  
 IAM H4 A0

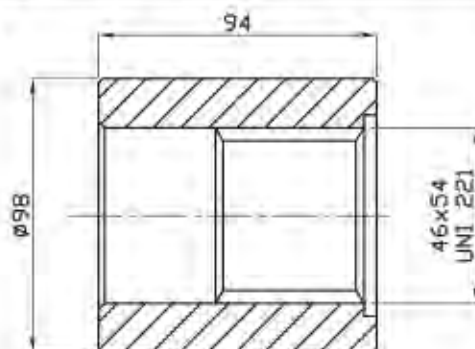
**SB5**

only for:

 IAM 450/C H3 A1  
 IAM H4 A1

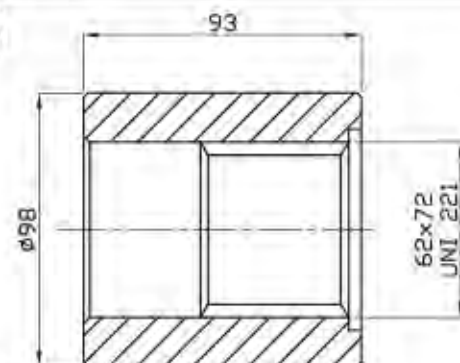
**SB6**

only for:

 IAM H5 A0  
 IAM 1200/C,1400/C,1500/C H5 A0

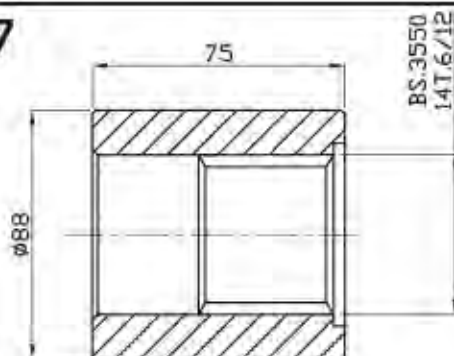
**SB7**

only for:

 IAM H5 A1  
 IAM 1000/B60,1400/B80,1600/B100 H5 A1

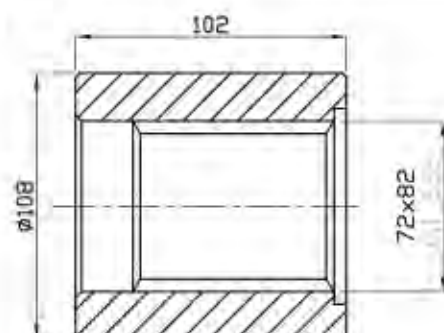
**SB8**

only for:

IAM 1600/C,1800/C,2000/C,2200/C H5 A0



## SB9

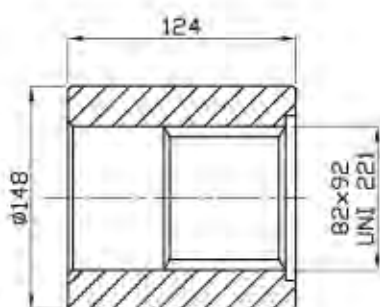

only for:  
IAM H6 A0  
IAM H6/C A0  
IAM 2200/B125,2500/B150,3000/B200 H6 A0

## SB10

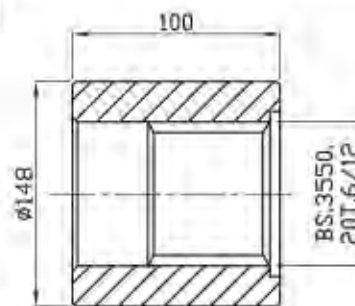

only for:  
IAM H6 A1  
IAM H6/C A1  
IAM 2200/B125,2500/B150,3000/B200 H6 A1  
IAM H7 A1  
IAM H8 A1

## SB11

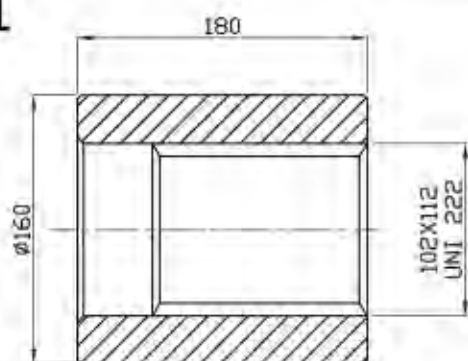

only for:  
IAM H7/C A0

## SB12

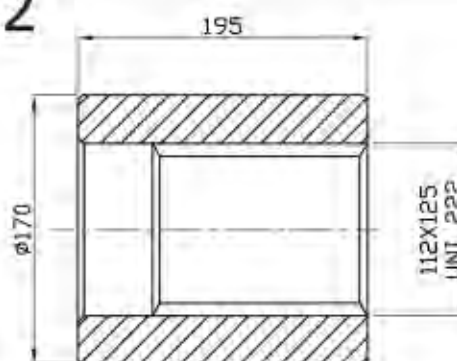

only for:  
IAM H8/C A0

## SB14

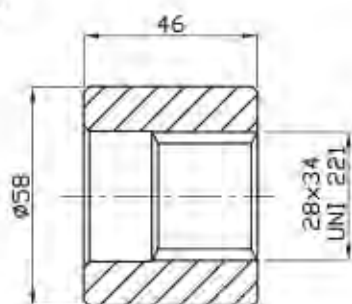

only for:  
IAM H1/GM1  
IAM H1/BH

## SB15

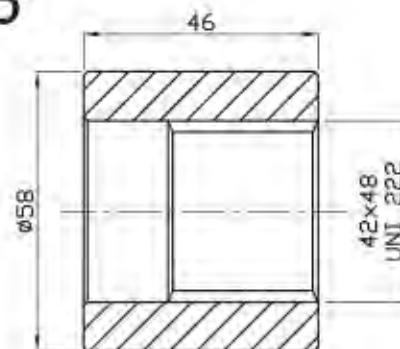

only for:  
IAM 300/C H2 A0

## SB16

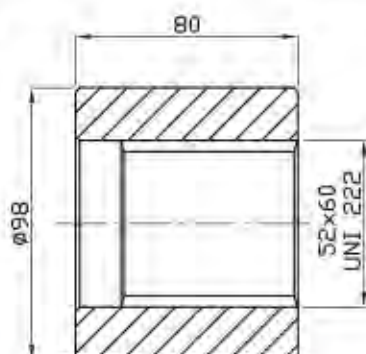

only for:  
IAM 700/C,800/C H4 A0

## SB17



only for:  
IAM H5/GM5 A0  
IAM H5/S A0

## CONVERSION FLANGES

### FL1

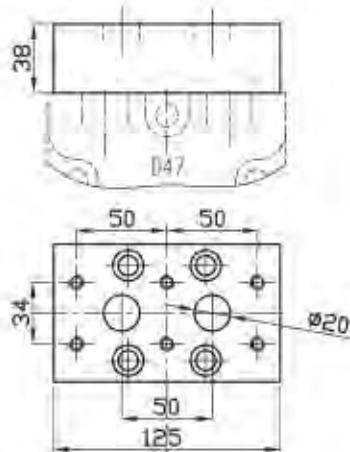

Connection block, fitting D47 distributor, for motor MR 160/190/250/300

### FL2

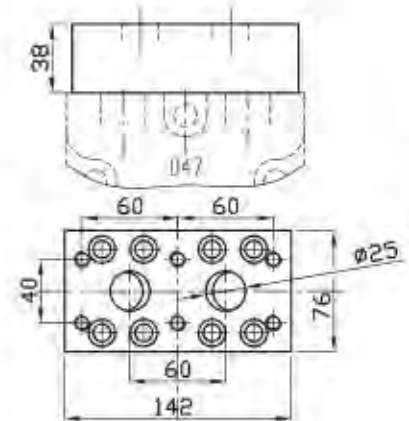

Connection block, fitting D47 distributor, for motor MR 350/450/500/600/700/800

### FL3

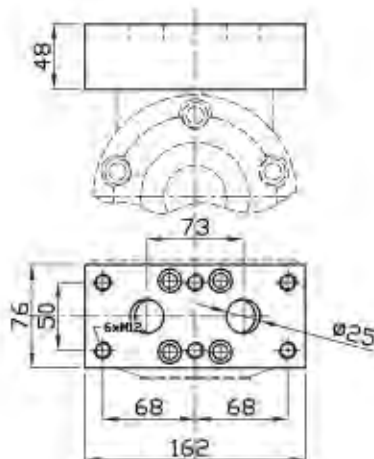

Connection block, fitting D55 distributor, for motor MR 1100/1400/1600/1800/2100

### FL4

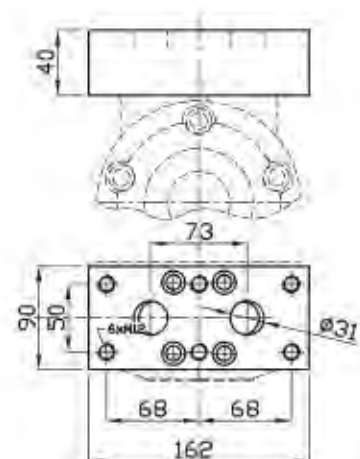

Connection block, fitting D75 distributor, for motor MR 1100/1400/1600/1800/2100

### FL5

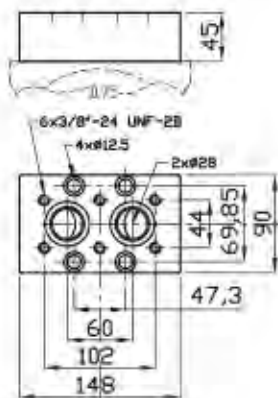

S03 plate for D75

### FL6

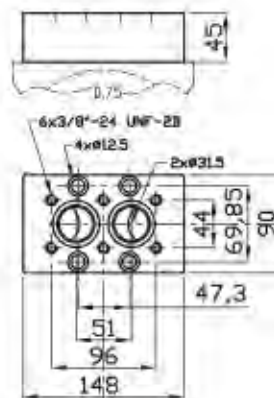

S04 plate for D75

### FL7

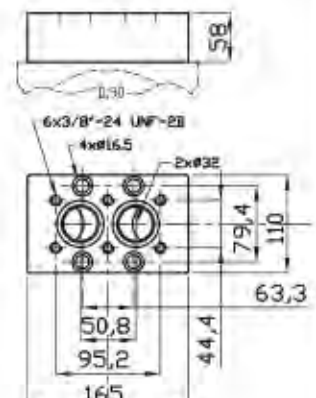

S04 plate for D90

## CONTACT US

Italgroup S.r.l.  
Via Pacinotti 20/22  
41010 - Gaggio di Piano (Modena) – Italy

Tel. +39 059 92 42 57  
Fax +39 059 92 01 13  
e-mail: [italgroup@italgroup.eu](mailto:italgroup@italgroup.eu)  
internet: <http://www.italgroup.eu>

## REACH US







**Europe**

Austria  
 Belgium  
 Croatia  
 Czech Republic  
 Cyprus  
 Denmark  
 Faroe Islands  
 France  
 Finland  
 Germany  
 Greece  
 Iceland  
 Italy  
 Netherland  
 Norway  
 Poland  
 Portugal  
 Russia  
 Slovenia  
 Spain  
 Sweden  
 Switzerland  
 Turkey  
 Ukraina  
 United Kingdom

**Africa**

Egypt  
 South Africa  
 Tunisia

**America**

Argentina  
 Brazil  
 Canada  
 Chile  
 Mexico  
 Peru  
 USA  
 Colombia

**Asia**

China  
 Hong Kong  
 India  
 Indonesia  
 Iran  
 Israel  
 Philippines  
 Russia  
 Belarus  
 Singapore  
 South Korea  
 Thailand  
 Taiwan  
 United Arab Emirates  
 Vietnam

**Oceania**

Australia  
 New Zeland



HYDRAULIC MOTORS

ITALY