

Internal Gear Pumps

Series QX

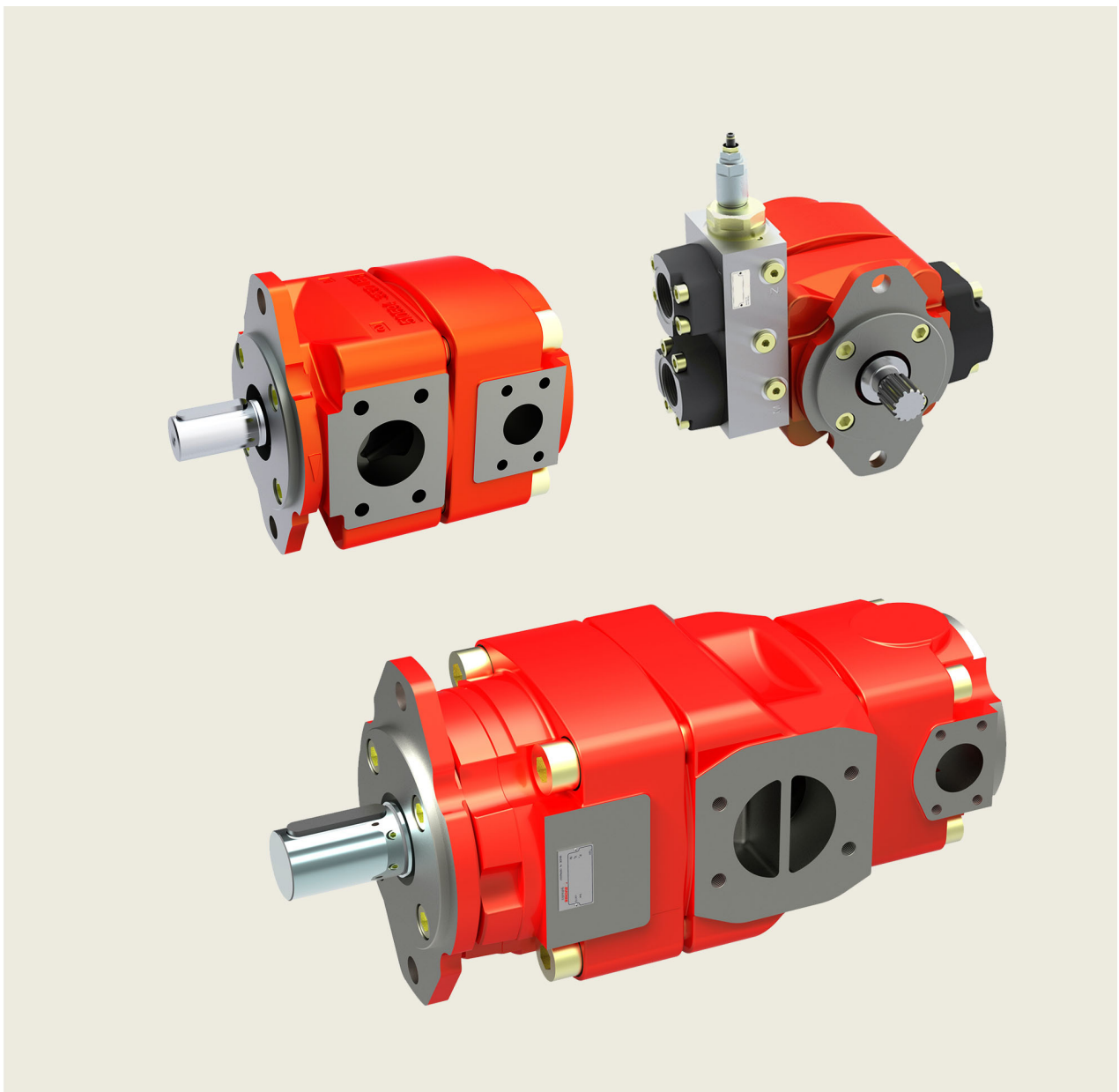

Contents

Page

1	General	5
	1.1 Product description	5
	1.2 Advantages	5
	1.3 ATEX compliant explosion protection	5
2	Technical data	5
	2.1 General (deviating values according manufacturer's specification)	5
	2.2 Main characteristics for pressure range 1	6
	2.3 Main characteristics for pressure range 2	7
	2.4 Main characteristics for pressure range 3	7
3	Performance graphs	8
	3.1 Noise level (Lp)	8
	3.2 Efficiency (η)	8
	3.3 Operation with variable-speed drives	9
4	Single pumps	10
	4.1 Dimensions	10
	4.2 Pressure range 1	11
	4.3 Pressure range 2	11
	4.4 Pressure range 3	12
	4.5 Ordering code for single pumps	12
	4.6 Standard configuration	12
	4.7 Options	12
5	Double pumps	13
	5.1 Selection table	13
	5.2 Dimensions	14
	5.3 Ordering code for double pumps	23
	5.4 Standard configuration	23
	5.5 Options	23
6	Triple pumps	24
	6.1 Selection table	24
	6.2 Ordering code for triple pumps	25
	6.3 Standard configuration	25
	6.4 Options	25
7	Low-flow capability pumps	26
	7.1 General	26
	7.2 Technical data	26
	7.3 Main characteristics	26

7.4	Volumetric efficiency (η)	27
7.5	Single pumps	27
7.6	QX24 pumps combined with other QX-single pumps	28
<hr/>		
8	Fluid	29
<hr/>		
9	Fluid cleanliness class	29
<hr/>		
10	Operational reliability	29
<hr/>		
11	Note	29
<hr/>		
12	Accessories	30
12.1	Bolt-on valves - SAE J518 code 61 / ISO 6162-1 pattern	30
12.2	Pipe flanges - high pressure type (thread flange)	31
12.3	Pipe flanges - low pressure type (welding flange)	31

1 General

1.1 Product description

The QX pumps are the 5th generation of Bucher internal gear pumps, which have proven themselves in thirty years of service around the world. Numerous improvements have been made to the straightforward and robust design.

Advances in the manufacturing process have made it possible without making higher demands on individual components to build pumps that are considerably lighter and more compact.

A new tooth profile, conceived and optimised with the help of CAE, has yielded another significant reduction in noise levels. Large sealing areas result in higher efficiencies.

The internal ring gear is supported by a hydrodynamic / hydrostatic lubrication film, which allows operation at low viscosities or low and high speeds. QX pumps are therefore suitable for use with variable speed drives, where they can provide variable flow rates.

1.3 ATEX compliant explosion protection

The internal gear pumps QX are suitable for application in hazardous areas and complies with the following guidelines:

ATEX directive	94/9/EC
group	II
equipment category	3
atmosphere	G
temperature class	T3 and T4

1.2 Advantages

- extremely long service life
- sound pressure level < 57 dB (A)
- volumetric efficiency up to 98%
- suitable for use with variable speed drivers
- can be used with fire resistant fluids (HFB, HFC and HFD = QXV), fuels, biodegradable and low-viscosity fluids
- certifications by ATEX 2, ABS, DNV, GL, LR, NK, ...
- low flow and pressure pulsations



II 3 G EEx c II T4
 -20°C ≤ Ta ≤ +40°C



II 3 G EEx c II T3
 -20°C ≤ Ta ≤ +80°C

2 Technical data

2.1 General (deviating values according manufacturer's specification)

General characteristics	Unit	Description, value
Installation attitude		unrestricted
Mounting method (standard)		oval 2-hole flange to ISO 3019/1 (SAE): QX 3-6 oval 2-hole flange to ISO 3019/2 (metric) QX 2+8
Direction of rotation		CW, alternatively CCW (but not reversible)
Pump drive method		in-line, through a flexible coupling
Volumetric efficiency η_v		up to 98%
Fluids		HLP mineral oils to DIN 51524, Part 2 HFC fluids to VDMA 24317
Maximum admissible level of contamination of the hydraulic fluid		NAS 1638, Class 9 or ISO 4406, code 20/18/15 (see section 9)
Operating viscosity Starting viscosity	mm ² /s	10 ... 100 * 10 ... 300 * *other values on request
Fluid temperature range	°C	HLP-mineral oils -20 min. / + 80 max. range for max. long life cycle +30 ... +60 (considering viscosity field)

Inlet pressure maximum minimum	bar	1.5 absolute (without external drain connection) 0.5 ... 0.98 absolute (dependent on pump frame size and speed, see example in section 3.3.2)
Startup against pressure	bar	Max. 20 (other values on request)



IMPORTANT: The main characteristics are valid for hydraulic oils DIN 51524 with a viscosity of 20 ... 50mm²/s. The operating pressure at the pump outlet side is specified also for fire-resistant fluids (HFC).

2.2 Main characteristics for pressure range 1

Displacement effective	Flow rate 1450 min ⁻¹ p = 0 bar	Maximum speed	Code	Max. operating pressure at the pump outlet side				Torque	Power consumption
				continuous [bar]		intermittent [bar] ²⁾			
				Mineral oil	HFC	Mineral oil	HFC		
[cm ³ /rev] ¹⁾	[l/min]	[rpm]					[Nm] ³⁾	[kW] ⁴⁾	
10,3	14,9	3600	QX21-010	160	130	210	180	26	4,0
12,6	18,3	3600	QX21-012	125	100	160	135	25	3,8
15,9	23,0	3600	QX21-016	100	80	125	100	25	3,9
20,0	29,0	3000	QX31-020	160	130	210	180	51	7,7
25,3	36,7	3000	QX31-025	125	100	160	135	50	7,7
31,2	45,2	3000	QX31-032	100	80	125	100	50	7,5
40,7	59,0	3000	QX41-040	160	130	210	180	104	15,7
50,3	72,9	2600	QX41-050	125	100	160	135	100	15,2
64,7	93,8	2300	QX41-063	100	80	125	100	103	15,6
78,6	114	2300	QX51-080	160	130	210	180	200	30,4
101,1	146	2100	QX51-100	125	100	160	135	201	30,5
127,3	184	1800 ⁵⁾	QX51-125	100	80	125	100	203	30,8
160,5	232	1800 ⁶⁾	QX61-160	160	130	210	180	409	62,0
202,1	293	1800 ⁶⁾	QX61-200	125	100	160	135	402	61,0
249,7	362	1800 ⁶⁾	QX61-250	100	80	125	100	397	60,4
326,0	472	1750 ⁶⁾	QX81-315	160	130	210	180	830	126,0
402,6	583	1750 ⁶⁾	QX81-400	125	100	160	135	801	121,6
498,5	722	1500 ⁶⁾	QX81-500	100	80	125	100	793	120,5

2.2.1 Suction arrangements for pump types QX61 and QX81



Minimum inlet pressure is 0.95 bar absolute with viscosity 10 ... 100 mm²/s (other values on request)

Type	Speed 1500 rpm Suction height		Speed 1800 rpm Suction height	
	up to 150 mm	over 150 mm	up to 150 mm	over 150 mm
QX61-160	I	I	I	II
QX61-200	I	I	I	II
QX61-250	I	II	II	II
QX81-315	I	II	II	II
QX81-400	II	II	II	-
QX81-500	II	II	-	-

I = standard pump with one suction port

II = model with two suction ports

All pump types coded II can be used without the second suction port up to 1200 rpm

2.3 Main characteristics for pressure range 2

Displacement	Flow rate	Maximum speed	Code	Max. operating pressure at the pump outlet side				Torque	Power consumption
				continuous [bar]		intermittent [bar] ²⁾			
				Mineral oil	HFC	Mineral oil	HFC		
[cm ³ /rev] ¹⁾	[l/min]	[rpm]							
effective	1450 min ⁻¹ p = 0 bar								
5,1 6,3 8,0	7,4 9,1 11,5	3600	QX22-005 QX22-006 QX22-008	210	180	250	210	17 21 27	2,6 3,2 4,0
10,0 12,6 15,6	14,5 18,3 22,6	3400	QX32-010 QX32-012 QX32-016	210	180	250	210	34 42 52	5,1 6,4 7,9
20,4 25,1 32,4	29,5 36,4 46,8	3200	QX42-020 QX42-025 QX42-032	210	180	250	210	68 84 108	10,4 12,7 16,5
39,3 50,6 63,7	56,9 73,2 92,1	2800	QX52-040 QX52-050 QX52-063	210	180	250	210	132 170 213	19,9 25,7 32,3
80,2 101,0 124,8	116 146 181	2500 ⁷⁾ 2300 ⁷⁾ 2000 ⁷⁾	QX62-080 QX62-100 QX62-125	210	180	250	210	268 338 417	40,7 51,2 63,4
163,0 201,3 249,2	236 291 361	1800 ⁷⁾ 1750 ⁷⁾ 1500 ⁷⁾	QX82-160 QX82-200 QX82-250	210	180	250	210	544 672 833	82,7 102,1 126,5

2.4 Main characteristics for pressure range 3

Displacement	Flow rate	Maximum speed	Code	Max. operating pressure at the pump outlet side				Torque	Power consumption
				continuous [bar]		intermittent [bar] ²⁾			
				Mineral oil	HFC	Mineral oil	HFC		
[cm ³ /rev] ¹⁾	[l/min]	[rpm]							
effective	1450 min ⁻¹ p = 0 bar								
5,1 6,3 8,0	7,4 9,1 11,5	3600	QX23-005 QX23-006 QX23-008	320	280	400	350	26 32 41	4,0 4,9 6,2
10,0 12,6 15,6	14,5 18,3 22,6	3400	QX33-010 QX33-012 QX33-016	320	280	400	350	51 64 80	7,7 9,7 12,1
20,4 25,1 32,4	29,5 36,4 46,8	3200	QX43-020 QX43-025 QX43-032	320	280	400	350	104 128 165	15,8 19,4 25,0
39,3 50,6 63,7	56,9 73,2 92,1	2800	QX53-040 QX53-050 QX53-063	320	280	400	350	200 258 321	30,4 39,1 49,3
80,2 101,0 124,8	116 146 181	2500 ⁷⁾ 2300 ⁷⁾ 2000 ⁷⁾	QX63-080 QX63-100 QX63-125	320	280	400	350	409 514 636	62,0 78,1 96,5
163,0 201,3 249,2	236 291 361	1800 ⁷⁾ 1750 ⁷⁾ 1500 ⁷⁾	QX83-160 QX83-200 QX83-250	320	280	400	350	830 1025 1270	126,0 155,7 192,7

1) Due to manufacturing tolerances, there may be slight variations in the displacement.

2) max. 20 second and not more than 10% of the duty cycle

3) theoretical value at the max. permitted continuous pressure for mineral oil

4) theoretical value at the max. permitted continuous pressures for mineral oil at n = 1450 rpm

5) for speeds > 1450 rpm, the min. permissible inlet pressure is 0.95 bar absolute. For HFC application a second suction port may be required

6) max. speed only possible with a second suction port, see section 2.2.1

7) for speeds > 1450 rpm, the min. permissible inlet pressure is 0.95 bar absolute.

3 Performance graphs



The performance graphs shown are valid for the specified pump models.
For other pump sizes, contact Bucher Hydraulics GmbH.

3.1 Noise level (L_p)

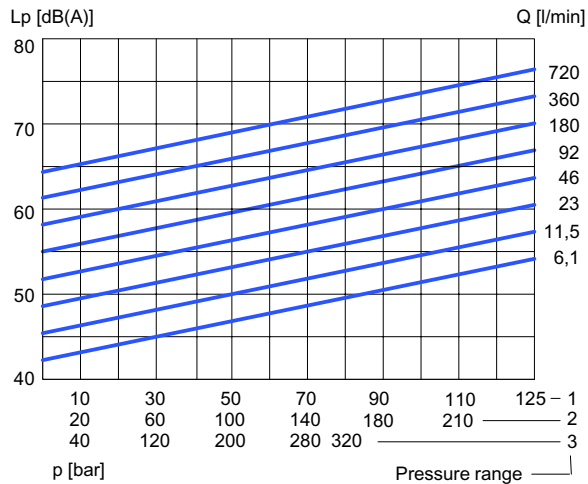

measured to DIN 45635, Part 26, in Stuttgart University's low-echo noise measurement chamber;
measurement distance 1 m; speed $n = 1500$ rpm; viscosity = $42 \text{ mm}^2/\text{s}$

3.2 Efficiency (η)

measured at speed 1450 rpm, viscosity $42 \text{ mm}^2/\text{s}$

3.2.1 Pressure range 1

Volumetric efficiency

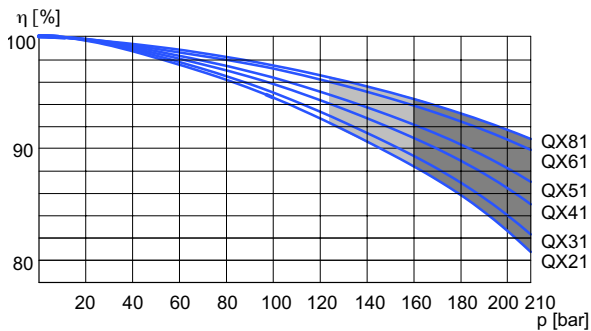

Hydromechanical efficiency

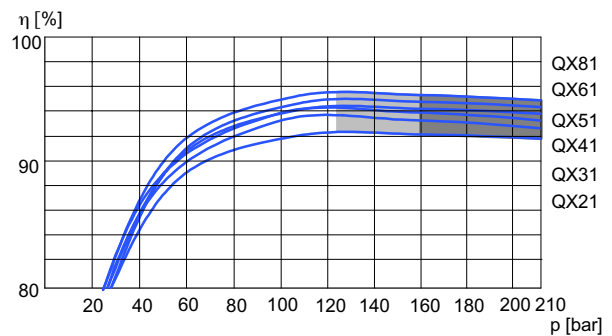

intermittent operating pressure as a function of displacement (see section 2.2)

3.2.2 Pressure range 2

Volumetric efficiency

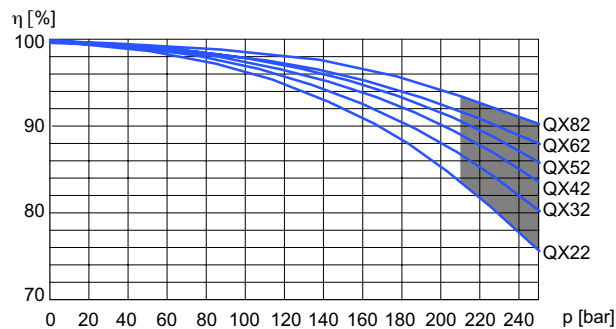

Hydromechanical efficiency

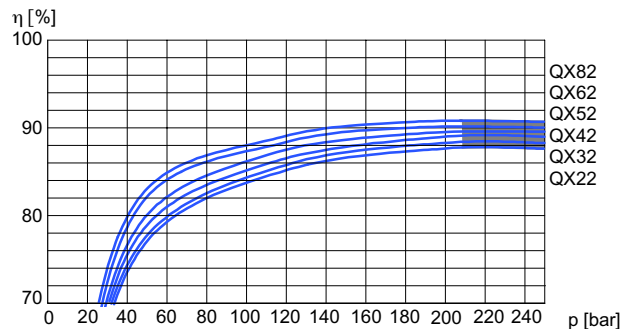

intermittent operating pressure

3.2.3 Pressure range 3

Volumetric efficiency

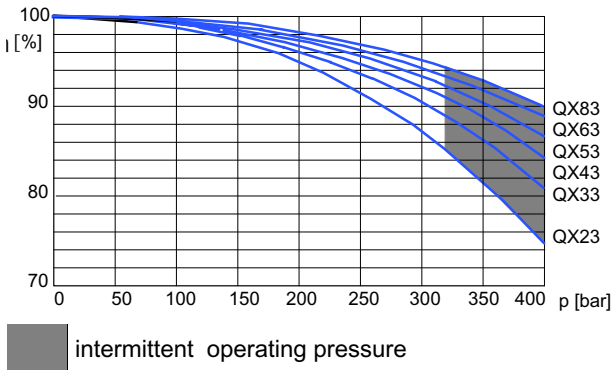

Hydromechanical efficiency

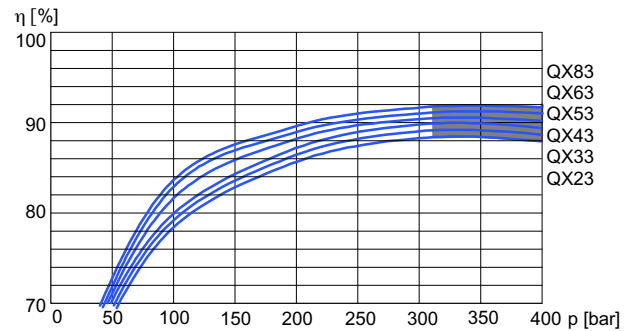

3.3 Operation with variable-speed drives



IMPORTANT:

The following main characteristics are to be understood as examples only. They are valid only for the specified pump models and parameters. We would be very happy to advise you on the layout of your drive. QX pumps with variable-speed drive all contain

an external drain port.

3.3.1 Typical loading cycle for a QX pump with variable-speed drive

Pump QX53-063 with viscosity 20 mm²/s

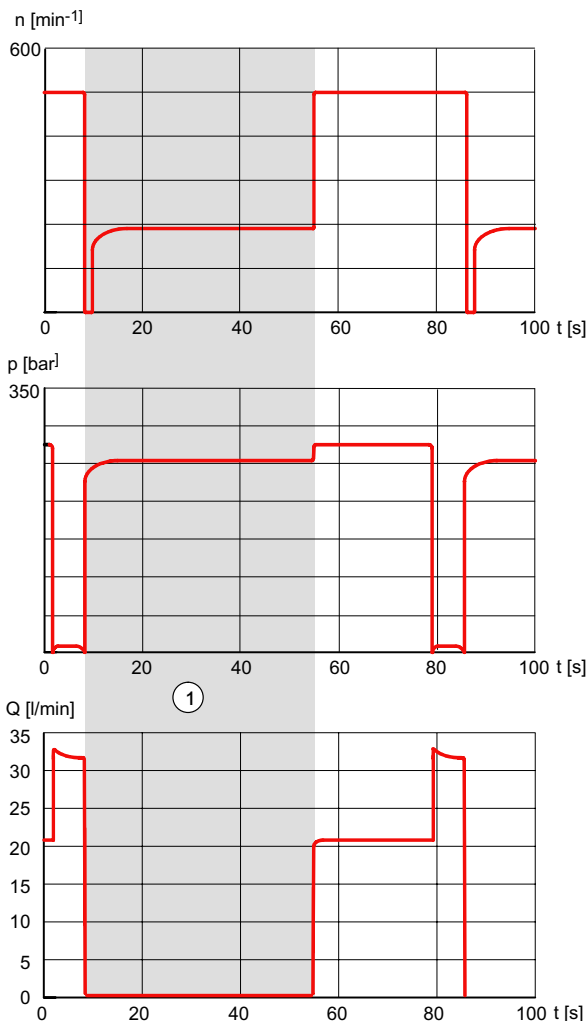

3.3.2 Minimum pressure at suction port as a function of speed

Pump QX53-063 measured: with viscosity 42 mm²/s

p [bar], Inlet pressure absolute

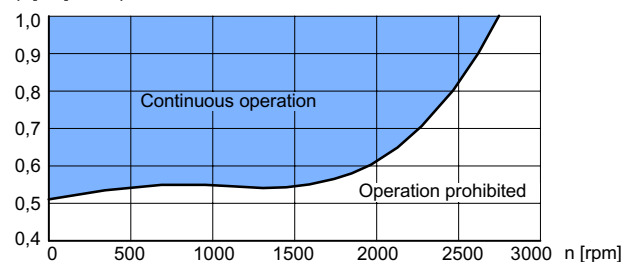

3.3.3 Minimum speed as a function of pressure

Pump QX53-063 measured with viscosity 42 mm²/s

p [bar]

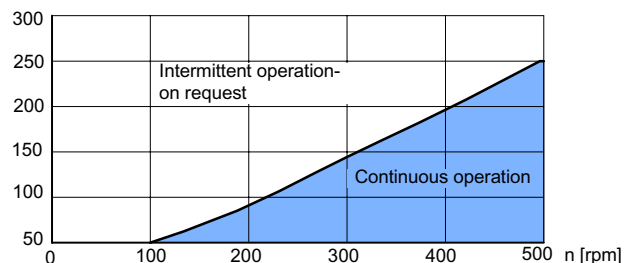

1

pressure-holding operation
Q = 0 l/min for up to 60 s

4 Single pumps

4.1 Dimensions

Frame size		2			3			4			5			6			8		
Pressure range		1	2	3	1	2	3	1	2	3	1	2	3	1	2	3	1	2	3
Suction port: to SAE J518 ¹⁾	S	G1 ³⁾ thread			G1 1/4 ³⁾ thread			1 1/2"			2"			2 1/2"			3"		
Pressure port: to SAE J518 ¹⁾	P	G1/2 ^{3) 4)} thread			G3/4 ^{3) 4)} thread			1"			1 1/4"			1 1/2"			2"		
External drain port (option 06)	①	G1/4"			G1/4"			G1/4"			G1/4"			G3/8 "			G1/2"		
Mounting: oval 2-hole- flange to ISO 3019/1 (SAE) ISO 3019/2 (metric)	A	118			132			170			212			267			330		
	B (SAE)	-			106			146			181			229			-		
	B (Metr.)	100			109			140			180			224			280		
	C	9			11			14			18			22			26		
	N (SAE)	-			82,55 - 0,05			101,6 - 0,05			127 - 0,05			152,4 - 0,05			-		
	N (Metr.)	63 h8			80 h8			100 h8			125 h8			160 h8			200 h8		
	O	8,5			8,5			10,5			12,5			16,5			20		
4-hole flange ISO 3019/2	X (Metr.)	9			9			12			14			18			22		
	Y (Metr.)	85			103			125			160			200			250		
Shaft end: parallel, to ISO/R775 ²⁾	D	20 j6			25 j6			32 j6			40 j6			50 j6			63 j6		
	E	36			42			58			82			82			105		
	F	6			8			10			12			14			18		
	G	22,5			28			35			43			53,5			67		
	I	45			50			68			92			92			117		
Housing	K	38			44			52			60			74			90		
	L	136	118	153	164	144	189	202	176	232	242	210	280	288	248	338	361	331	446
	M	-	55	90	-	70	114	-	87	143	-	102	172	-	119	209	-	151	266
	T1	43			54			67			89			107	110		137	138	
	T2	43			54	60		67	70		89			107	110		137	138	
	Z	100			120			125			156			195	197		250		
	W	80			100			136			165			203			256		
Weight	kg	5	5	6,5	10	9,5	12,5	18	17	22	33	31	40	64	60	76	130	120	160

1) pipe flange dimensions, SAE J518 code 61 / ISO 6162-1
high pressure type up to 420 bar (see section 10.2)
low pressure type for up to 16 bar (see section 10.3)

2) for other shaft ends, contact Bucher Hydraulics GmbH

3) threaded port to DIN 3852, Part 2

4) pressure port to SAE J518 code 61 / ISO 6162-1 can be supplied for pressure ranges 2 + 3

4.2 Pressure range 1

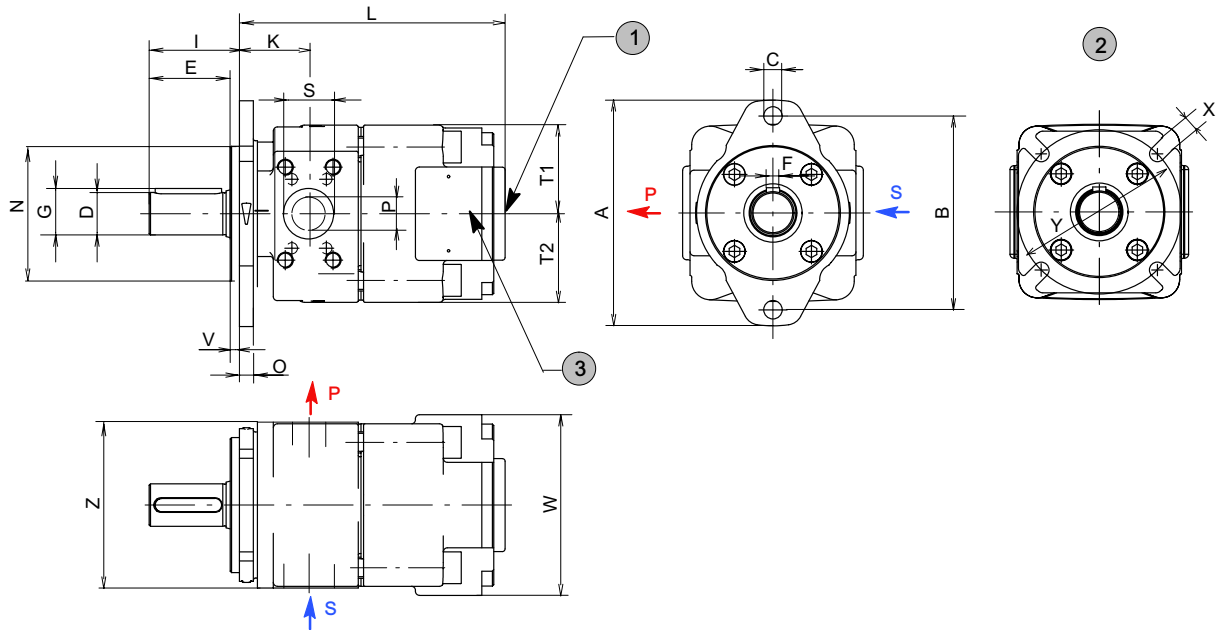

1 external drain port - see special feature 06

2 special model: 4-hole flange ISO 3019/2

3 depending on operating conditions, a second suction port may be required on QX61 (SAE 2") and QX81 (SAE 2 1/2") - see section 2.2.1

4.3 Pressure range 2

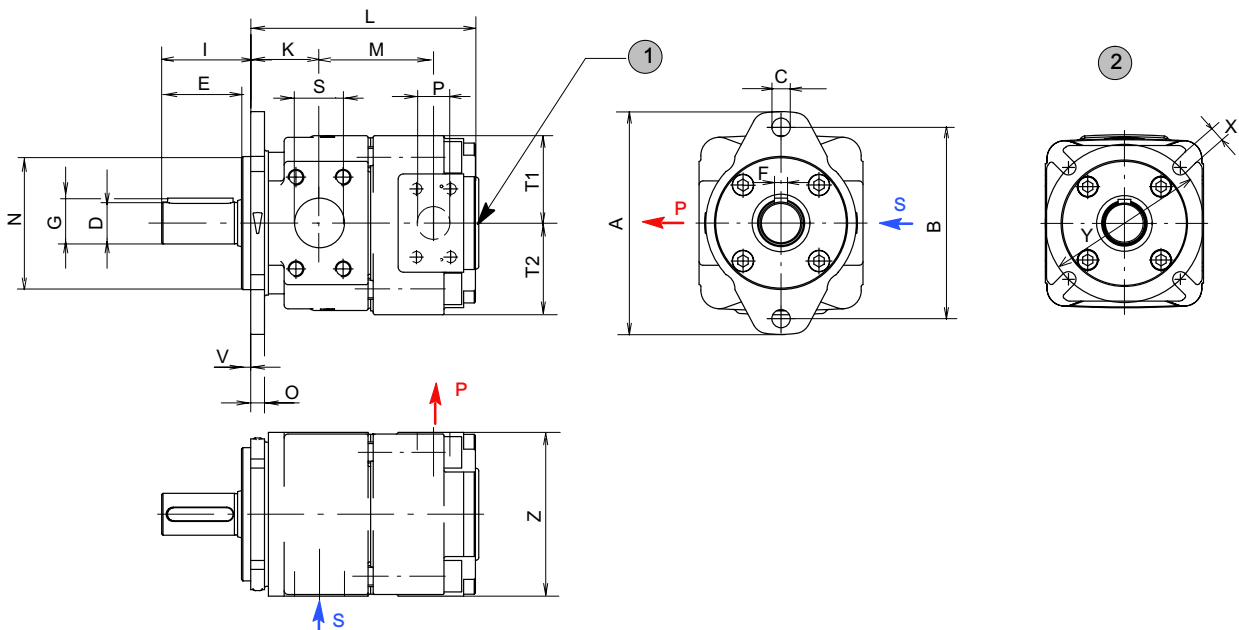

1 external drain port - see special feature 06

2 special model: 4-hole flange ISO 3019/2

4.4 Pressure range 3

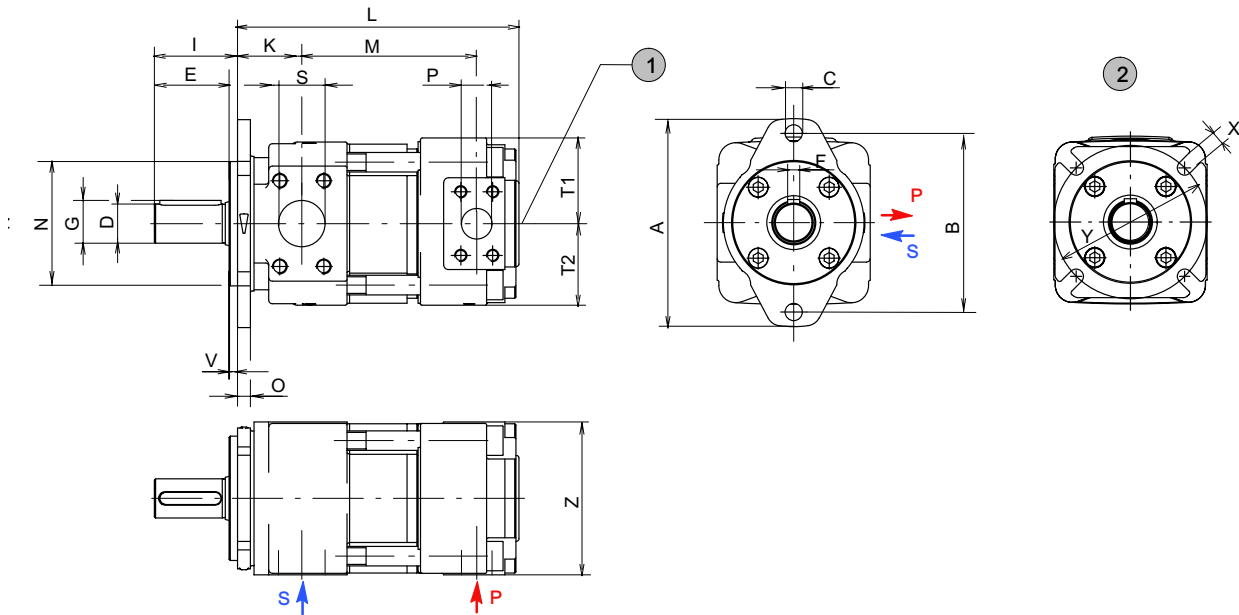

1 external drain port - see special feature 06

2 special model: 4-hole flange ISO 3019/2

4.5 Ordering code for single pumps

Series	= QX	Q	X	5	3	-	0	4	0	R	*	*
Frame size	= 2 / 3 / 4 / 5 / 6 / 8											
Pressure range	= 1 / 2 / 3											
Displacement [cm ³ /rev]	= 005 - 500											
Rotation (viewed from shaft end)	right (CW) = R (standard) left (CCW) = L											
Option	see section 4.7											

Ordering example:

Required: single pump
 Displacement: 40 cm³/rev
 Continuous pressure: 300 bar
 for use with mineral oil
 Ordering code: QX53-040R

4.6 Standard configuration

- direction of rotation - right (CW)
- 2-hole mounting flange to ISO 3019/1 (SAE): sizes QX 3-6
- 2-hole mounting flange to ISO 3019/2 (metr.): sizes QX 2+8
- Nitrile seals
- cylindrical shaft end to ISO R775
- black priming, flange without priming

4.7 Options

- O = without priming
- 06 = external drain port in the pump rear cover
 QX 2-5 = G1/4", QX 6 = G3/8", QX 8 = G1/2"
- 09 = Viton seals and without priming
- 12 = 2-hole mounting flange to ISO 3019/2 (metric): size QX 3-6
- 29 = for HFB and HFC fluids, frame sizes 2-5, without priming
- 66 = 4-hole mounting flange to ISO 3019/2 (metric)
- 83 = second suction port on:
 QX61 = SAE 2", QX81 = SAE 2 1/2"
- 86 = for HFB and HFC fluids, frame sizes 6+8, without priming
- 117 = pressure port to SAE J518 code 61 / ISO 6162-1 can be supplied for frame size 2+3 with pressure ranges 2+3

Further options on request.

5 Double pumps

QX double pumps consist of two single pumps mounted on a common drive shaft. Hydraulically, the two pumps operate independently of one another but they share a common suction port in the pump's centre section. The larger pump of the combination is situated at the shaft end (the drive side) and is referred to as Pump 1. With equal frame sizes, the pump with the larger displacement is situated at the drive side.

Double pumps can be combined as shown in the following table. If a letter is shown at the intersection point of the two pumps, the letter identifies the page in section 5.2 that contains the relevant dimensional drawing. If there is no letter at the intersection point, then that pump combination is not possible.

5.1 Selection table

		Pump 2																				Maximum permissible torque [Nm] drive side					
		Displacement [cm ³ /rev]																									
		5/6/8			10/12/16			20/25/32			40/50/63			80/100/125			160/200/250			315	400		500				
		Maximum intermittent pressure [bar]																									
		250		400		125 160 210		250		400		125 160 210		250		400		125 160 210		250		400		125 160 210			
		QX22...	QX23...	QX21..	QX32...	QX33...	QX31..	QX42...	QX43...	QX41..	QX52...	QX53...	QX51..	QX62...	QX63...	QX61...	QX82...	QX83...	QX81...								
Pump 1	Displacement [cm ³ /rev]	5/6/8	250	QX22..	E																					65	
			400	QX23..	H	I																					
	10/12/16	125/160 210	QX21..	B	C	A																					130
		250	QX32..	E	F	D	E																				
	20/25/32	400	QX33..	H	I	G	H	I																			260
		125/160 210	QX31..	B	C	A	B	C	A																		
	40/50/63	250	QX42..	E	F	D	E	F	D	E																	520
		400	QX43..	H	I	G	H	I	G	H	I																
	80/100/125	125/160 210	QX41..	B	C	A	B	C	A	B	C	A															1050
		250	QX52..	E	F	D	E	F	D	E	F	D	E														
	160/200/250	400	QX53..	H	I	G	H	I	G	H	I	G	H	I													2100
		125/160 210	QX51..	B	C	A	B	C	A	B	C	A	B	C	A												
	315 400 500	160/200/250	250	QX62..				E	F	D	E	F	D	E	F	D	E										2100
			400	QX63..				H	I	G	H	I	G	H	I	G	H	I									
	315 400 500	160/200/250	125/160 210	QX61..				B	C	A	B	C	A	B	C	A	B	C	A								2100
			250	QX82..							E	F	D	E	F	D	E	F	D	E	F	D	E				
	315 400 500	160/200/250	400	QX83..							H	I	G	H	I	G	H	I	G	H	I	G	H	I			2100
			125/160 210	QX81..							B	C	A	B	C	A	B	C	A	B	C	A	B	C	A		

5.2 Dimensions

A Double pumps QX.1/1

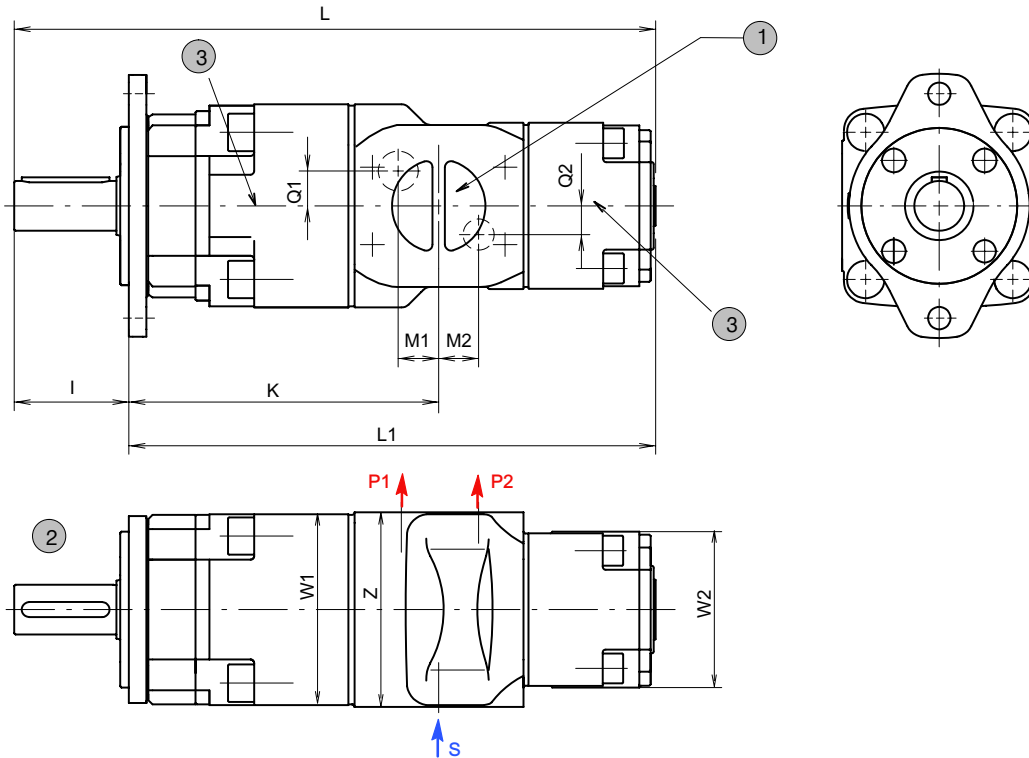

1	S = common suction port
2	shaft and mounting dimensions see section 4

3	depending on operating conditions, a second suction port may be required - see section 2.2.1, QX61 SAE 2", QX81 SAE 2 1/2"
---	--

Typ	L	L1	K	M1	M2	Q1	Q2	I	Z	W1	W2	S	P1	P2
QX21/21	296	251	141	18	18			45	100	80	80	G 1 1/4" ¹⁾	G 1/2" ^{1) 2)}	
QX31/21	343	293	171	26	30			50	120	100	80	G 1 1/2" ¹⁾	G 3/4" ^{1) 2)}	G 1/2" ^{1) 2)}
QX31/31	358	308			26	-	-			G 3/4" ^{1) 2)}				
QX41/21	396	328	201	19	35	15	15	68	125	136	80	SAE 2"	SAE 1"	G 1/2" ^{1) 2)}
QX41/31	411	343			33	23				23	G 3/4" ^{1) 2)}			
QX41/41	449	381	208	26	26	23	23			136	136			SAE 1"
QX51/21	468	376	241	23	43	15	15	92	156	165	80	SAE 2 1/2"	SAE 1 1/4"	G 1/2" ^{1) 2)}
QX51/31	483	391			39	23				23	G 3/4" ^{1) 2)}			
QX51/41	521	429	249	30	32	28	28	92	195	165	136	SAE 3"	SAE 1 1/2"	SAE 1"
QX51/51	547	455			30	28				28	SAE 1 1/4"			
QX61/31	541	449	287	24	47	17	14	92	195	203	100	SAE 3 1/2"	SAE 1 1/2"	G 3/4" ^{1) 2)}
QX61/41	564	472			27	39	26			27	203			136
QX61/51	601	509	292	32	40	35	28	117	250	203	165	SAE 3 1/2"	SAE 1 1/2"	SAE 1 1/4"
QX61/61	628	536			32	35				35	203			203
QX81/41	679	562	359	35	51	25	25	117	250	250	136	SAE 3 1/2"	SAE 2"	SAE 1"
QX81/51	705	588			47	30	30			250	165			SAE 1 1/4"
QX81/61	732	615		38	45	40	40			250	203	SAE 1 1/2"		
QX81/81	774	657				38	40			40	256	256	SAE 2"	

1) threaded port to DIN 3852, Part 2

2) pressure port to SAE J518 code 61 / ISO 6162-1 can be supplied for pressure ranges 2+3

B Double pumps QX.1/2

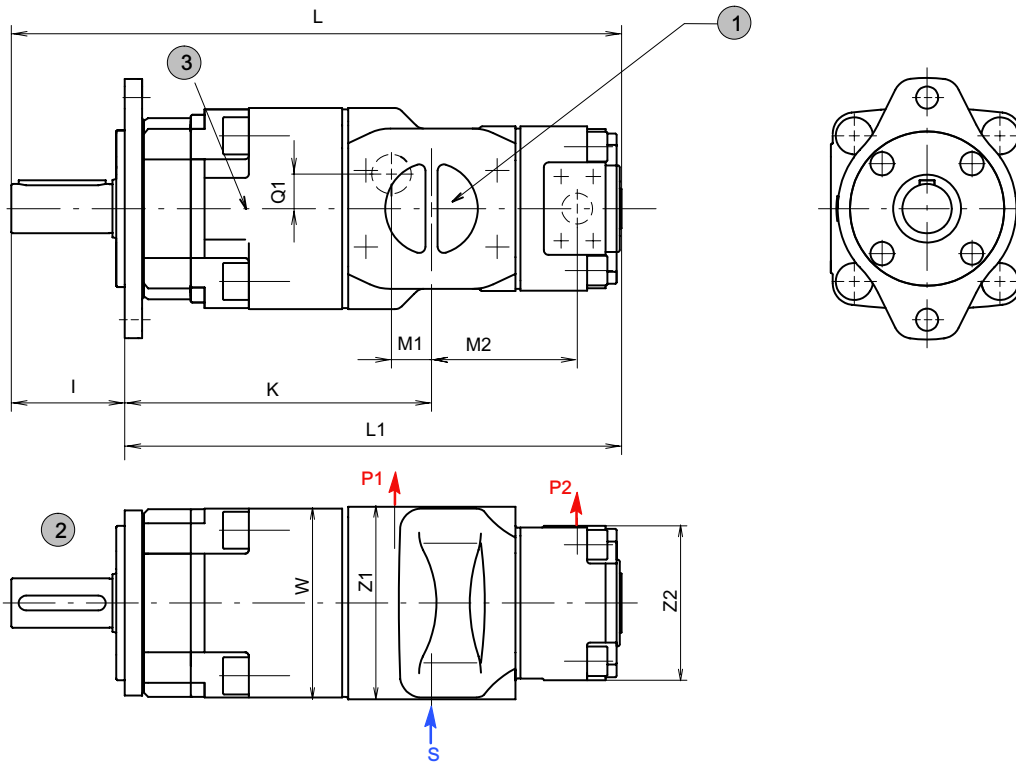

1	S = common suction port
2	shaft and mounting dimensions see section 4

3	depending on operating conditions, a second suction port may be required - see section 2.2.1, QX61 SAE 2", QX81 SAE 2 1/2"
---	--

Typ	L	L1	K	M1	M2	Q1	I	Z1	Z2	W	S	P1	P2	
QX21/22	278	233	141	18	67	-	45	100	100	80	G 1 1/4" ¹⁾	G 1/2" ^{1) 2)}	G 1/2" ^{1) 2)}	
QX31/22	325	275	171	26	79		50	120	100	100	G 1 1/2" ¹⁾	G 3/4" ^{1) 2)}	G 3/4" ^{1) 2)}	
QX31/32	338	288			87	15	68	125	100	136	SAE 2"	SAE 1"	G 1/2" ^{1) 2)}	
QX41/22	378	310	201	19	84	23	68	125	100	136	SAE 2"	SAE 1"	G 1/2" ^{1) 2)}	
QX41/32	391	323			92				120				G 3/4" ^{1) 2)}	
QX41/42	423	355	208	26	111	23	68	125	125	136	SAE 2"	SAE 1"	SAE 1"	
QX51/22	450	358	241	23	92	15	92	156	100	165	SAE 2 1/2"	SAE 1 1/4"	G 1/2" ^{1) 2)}	
QX51/32	463	371			100				120				G 3/4" ^{1) 2)}	
QX51/42	495	403	249	30	118	28	92	156	125	165	SAE 3"	SAE 1 1/4"	SAE 1"	
QX51/52	515	423			127				156				SAE 1 1/4"	
QX61/32	521	429	287	24	112	17	92	195	120	203	SAE 3"	SAE 1 1/2"	G 3/4" ^{1) 2)}	
QX61/42	538	446			27				123				26	125
QX61/52	569	477	292	32	137	35	92	195	156	203	SAE 3 1/2"	SAE 1 1/2"	SAE 1 1/4"	
QX61/62	588	496			149				197				SAE 1 1/2"	
QX81/42	653	536	359	35	141	25	117	250	125	256	SAE 3 1/2"	SAE 2"	SAE 1"	
QX81/52	673	556			150				156				SAE 1 1/4"	
QX81/62	692	575		38	162	40			197				197	SAE 1 1/2"
QX81/82	724	607							179				250	SAE 2"

1) threaded port to DIN 3852, Part 2

2) pressure port to SAE J518 code 61 / ISO 6162-1 can be supplied for pressure ranges 2+3

C Double pumps QX.1/3

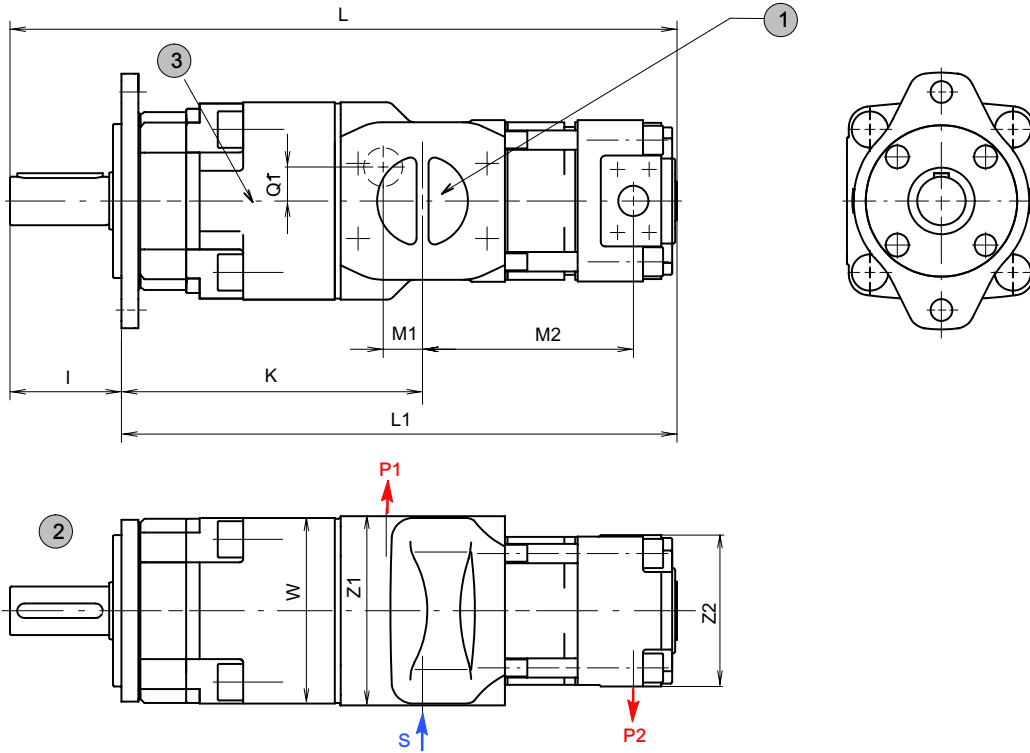

1	S = common suction port
2	shaft and mounting dimensions see section 4

3	depending on operating conditions, a second suction port may be required - see section 2.2.1, QX61 SAE 2", QX81 SAE 2 1/2"
---	--

Typ	L	L1	K	M1	M2	Q1	I	Z1	Z2	W	S	P1	P2
QX21/23	313	268	141	18	102	-	45	100	100	80	G 1 1/4" ¹⁾	G 1/2" ^{1) 2)}	G 1/2" ^{1) 2)}
QX31/23	360	310	171	26	114		50	120	100	100	G 1 1/2" ¹⁾	G 3/4" ^{1) 2)}	G 3/4" ^{1) 2)}
QX31/33	383	333			132		120						
QX41/23	413	345	201	19	119	15	68	125	100	136	SAE 2"	SAE 1"	G 1/2" ^{1) 2)}
QX41/33	436	368			137				120				G 3/4" ^{1) 2)}
QX41/43	479	411			167				125				SAE 1"
QX51/23	485	393	241	23	127	15	92	156	100	165	SAE 2 1/2"	SAE 1 1/4"	G 1/2" ^{1) 2)}
QX51/33	508	416			145				120				G 3/4" ^{1) 2)}
QX51/43	551	459	249	30	174	28	92	156	125	203	SAE 3"	SAE 1 1/2"	SAE 1"
QX51/53	585	493			197				156				SAE 1 1/4"
QX61/33	566	474	287	24	157	17	92	195	120	203	SAE 3"	SAE 1 1/2"	G 3/4" ^{1) 2)}
QX61/43	594	502		27	179	26			125				SAE 1"
QX61/53	637	545	292	32	207	35	92	195	156	256	SAE 3 1/2"	SAE 2"	SAE 1 1/4"
QX61/63	678	586			239				197				SAE 1 1/2"
QX81/43	709	592	359	35	197	25	117	250	125	256	SAE 4"	SAE 2"	SAE 1"
QX81/53	743	626			220				156				SAE 1 1/4"
QX81/63	782	665		252	197	SAE 1 1/2"							
QX81/83	839	722	38	294	40			250					SAE 2"

1) threaded port to DIN 3852, Part 2

2) pressure port to SAE J518 code 61 / ISO 6162-1 can be supplied for pressure ranges 2+3

D Double pumps QX.2/1

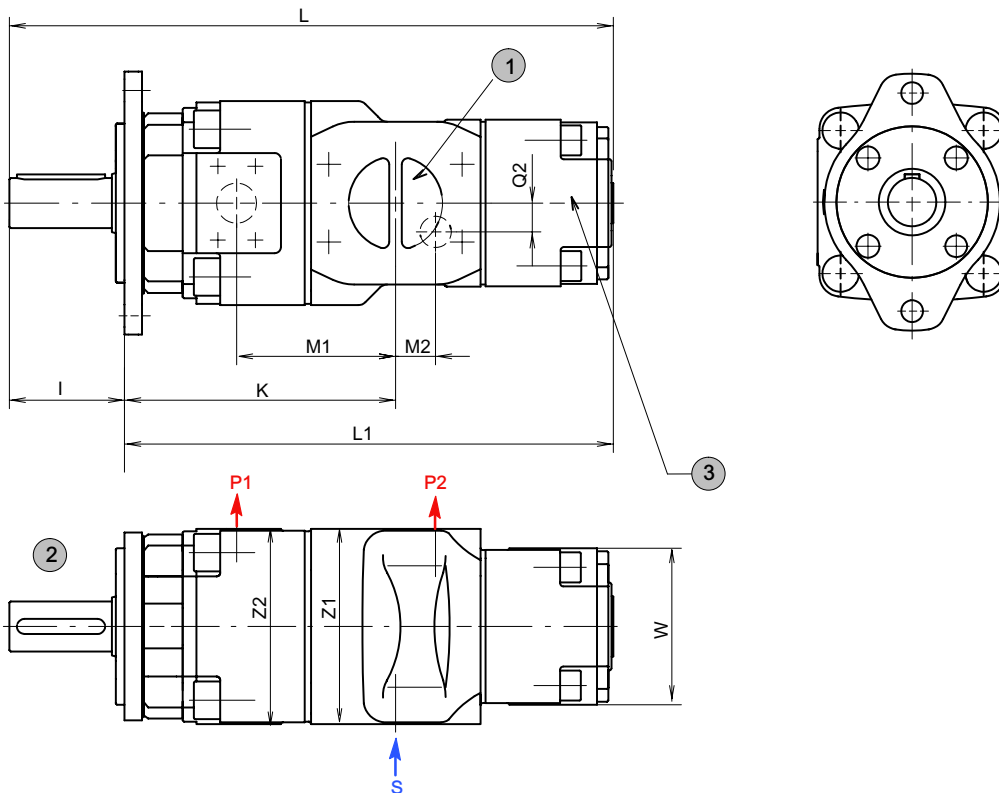

- | | |
|---|---|
| 1 | S = common suction port |
| 2 | shaft and mounting dimensions see section 4 |

- | | |
|---|---|
| 3 | depending on operating conditions, a second suction port may be required - see section 2.2.1, QX61 SAE 2" |
|---|---|

Typ	L	L1	K	M1	M2	Q2	I	Z1	Z2	W	S	P1	P2	
QX32/21	323	273	151	87	30	-	50	120	120	80	G 1 1/2" ¹⁾	G 3/4" ^{1) 2)}	G 1/2" ^{1) 2)}	
QX42/21	370	302	175	103	35	-	68	125	125	100	SAE 2"	SAE 1"	G 3/4" ^{1) 2)}	
QX42/31	385	317			33	15								
QX52/21	436	344	209	120	43	-	92	156	156	80	SAE 2 1/2"	SAE 1 1/4"	G 1/2" ^{1) 2)}	
QX52/31	451	359			39	15							G 3/4" ^{1) 2)}	
QX52/41	489	397	217	127	32	23	92	195	197	136	SAE 3"	SAE 1 1/2"	SAE 1"	
QX62/31	501	409	247	144	47	14							100	G 3/4" ^{1) 2)}
QX62/41	524	432			39	27	92	195	197	136	SAE 3 1/2"	SAE 1 1/2"	SAE 1"	
QX62/51	561	469	252	149	40	28								165
QX82/41	629	512	309	179	51	25	117	250	250	136	SAE 3 1/2"	SAE 2"	SAE 1"	
QX82/51	655	538			47	30							165	SAE 1 1/4"
QX82/61	682	565			45	35							203	SAE 4"

1) threaded port to DIN 3852, Part 2

2) pressure port to SAE J518 code 61 / ISO 6162-1 can be supplied for pressure ranges 2+3

E Double pumps QX.2/2

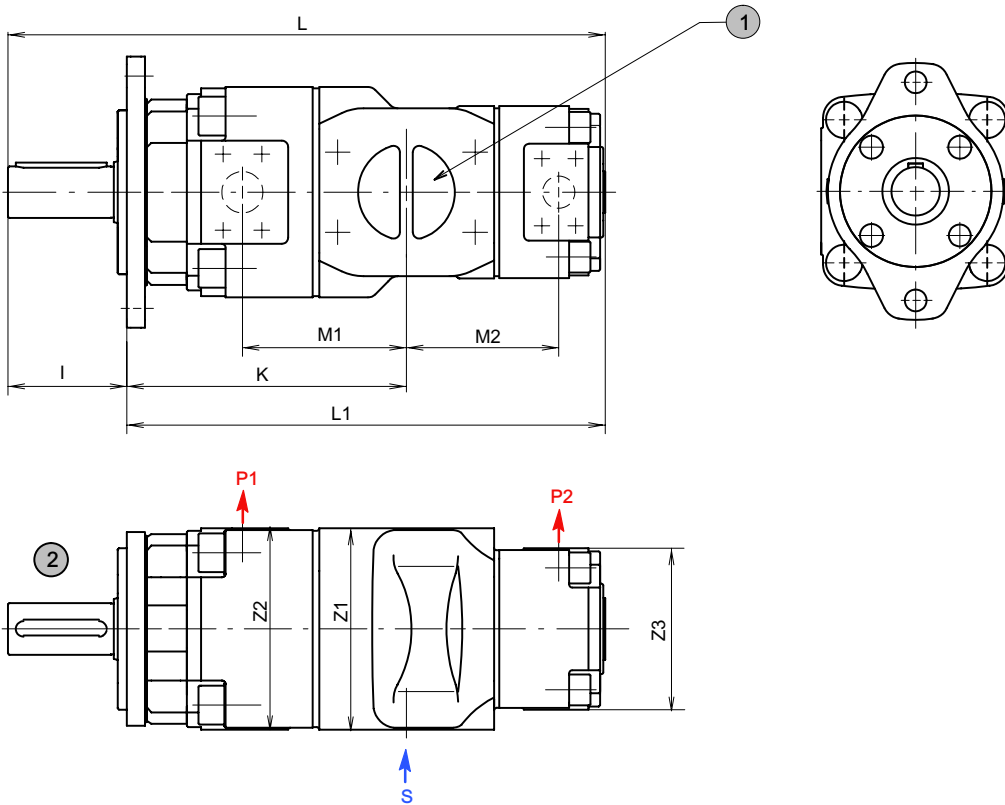

1 S = common suction port

2 shaft and mounting dimensions - see section 4

Typ	L	L1	K	M1	M2	I	Z1	Z2	Z3	S	P1	P2
QX22/22	260	215	123	67	67	45	100		100	G 1 1/4" ¹⁾	G 1/2" ^{1) 2)}	G 1/2" ^{1) 2)}
QX32/22	305	255	151	87	79	50	120		100	G 1 1/2" ¹⁾	G 3/4" ^{1) 2)}	G 3/4" ^{1) 2)}
QX32/32	318	268			87			120				
QX42/22	352	284	175	103	84	68	125		100	SAE 2"	SAE 1"	G 1/2" ^{1) 2)}
QX42/32	365	297			92			120	G 3/4" ^{1) 2)}			
QX42/42	397	329	182	111	111			125	125		SAE 1"	SAE 1"
QX52/22	418	326	209	120	92	92	156		100	SAE 2 1/2"	SAE 1 1/4"	G 1/2" ^{1) 2)}
QX52/32	431	339			100			120	G 3/4" ^{1) 2)}			
QX52/42	463	371	217	127	118			125	125	SAE 3"	SAE 1 1/4"	SAE 1"
QX52/52	483	391			127	156	SAE 1 1/4"					
QX62/32	481	389	247	144	112	92	195	197	120	SAE 3 1/2"	SAE 1 1/2"	G 3/4" ^{1) 2)}
QX62/42	498	406			123				125			SAE 1"
QX62/52	529	437	252	149	137			156	156	SAE 3 1/2"	SAE 1 1/2"	SAE 1 1/4"
QX62/62	548	456			149	197	SAE 1 1/2"					
QX82/42	603	486	309	179	141	117	250		125	SAE 4"	SAE 2"	SAE 1"
QX82/52	623	506			150			156	SAE 1 1/4"			
QX82/62	642	525			162			197	SAE 1 1/2"			
QX82/82	674	557			179			250	SAE 2"			

1) threaded port to DIN 3852, Part 2

2) pressure port to SAE J518 code 61 / ISO 6162-1 can be supplied for pressure ranges 2+3

F Double pumps QX.2/3

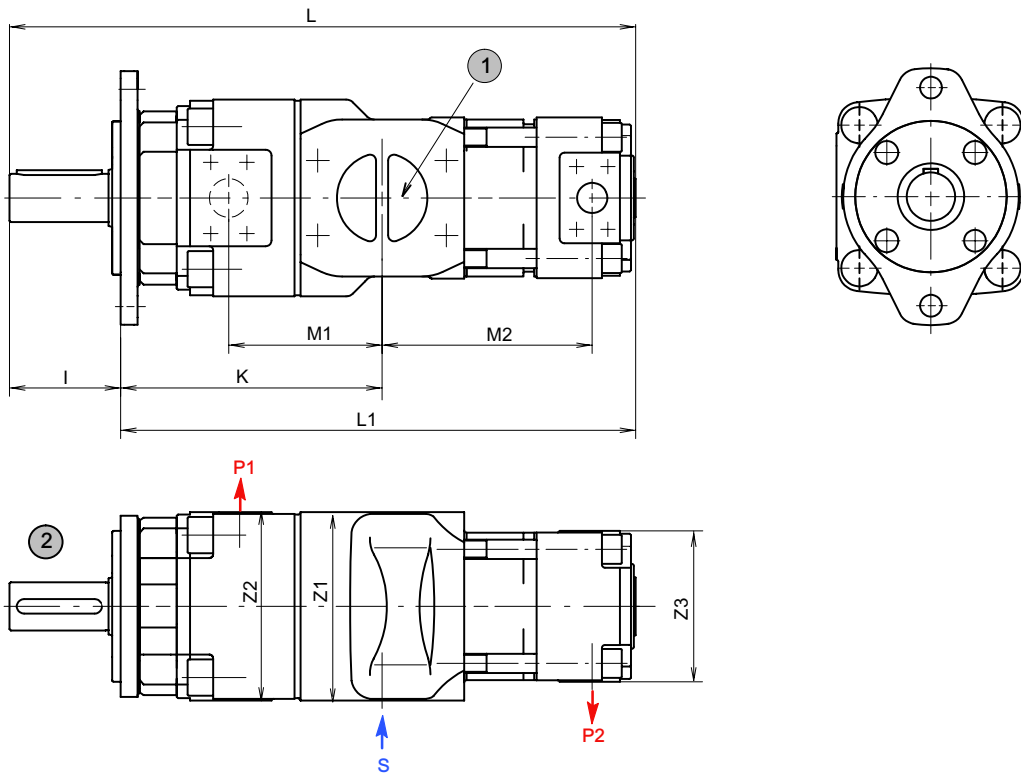

1 S = common suction port

2 shaft and mounting dimensions - see section 4

Typ	L	L1	K	M1	M2	I	Z1	Z2	Z3	S	P1	P2	
QX32/23	340	290	151	87	114	50	120		100	G 1 1/2" ¹⁾	G 3/4" ^{1) 2)}	G 1/2" ^{1) 2)}	
QX42/23	387	319	175	103	119	68	125			SAE 2"	SAE 1"	G 3/4" ^{1) 2)}	
QX42/33	410	342			137				120				
QX52/23	453	361	209	120	127	92	156		100	SAE 2 1/2"	SAE 1 1/4"	G 1/2" ^{1) 2)}	
QX52/33	476	384			145							120	G 3/4" ^{1) 2)}
QX52/43	519	427			217			174	125			SAE 1"	
QX62/33	526	434	247	144	157	92	195	197	120	SAE 3"	SAE 1 1/2"	G 3/4" ^{1) 2)}	
QX62/43	554	462			179								125
QX62/53	599	507			252				207			156	SAE 1 1/4"
QX82/43	659	542	309	179	197	117	250		125	SAE 3 1/2"	SAE 2"	SAE 1"	
QX82/53	693	576			220							156	SAE 1 1/4"
QX82/63	732	615			252				197			SAE 4"	SAE 1 1/2"

1) threaded port to DIN 3852, Part 2

2) pressure port to SAE J518 code 61 / ISO 6162-1 can be supplied for pressure ranges 2+3

G Double pumps QX.3/1

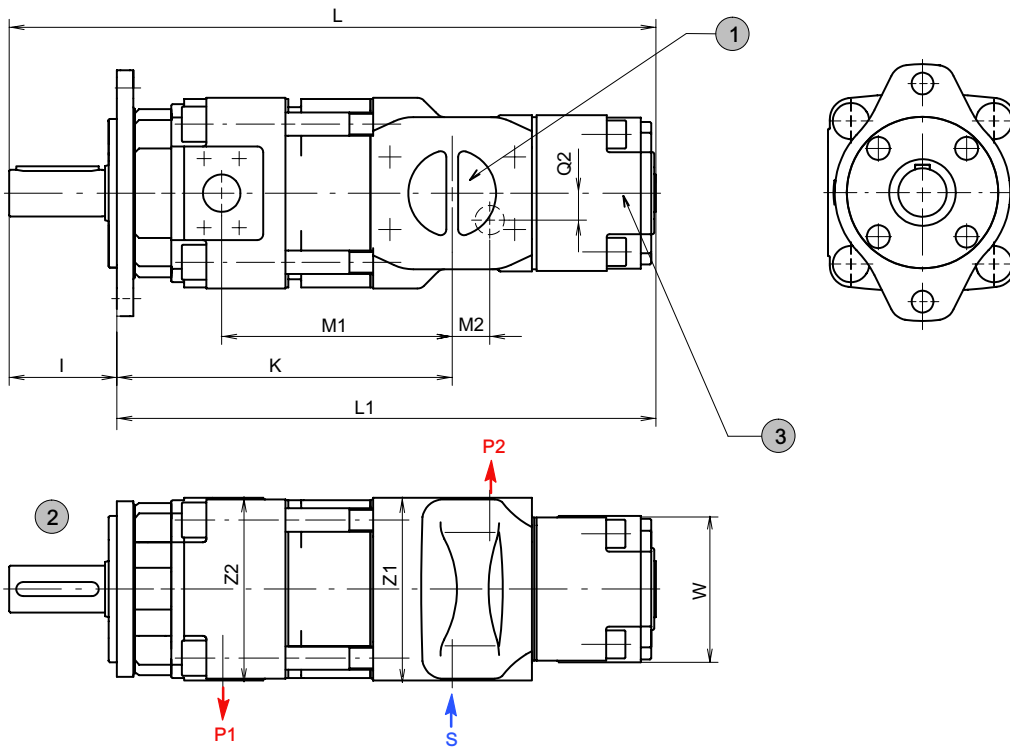

1	S = common suction port
2	shaft and mounting dimensions - see section 4

3	depending on operating conditions, a second suction port may be required - see section 2.2.1 QX61 SAE 2"
---	--

Typ	L	L1	K	M1	M2	Q2	I	Z1	Z2	W	S	P1	P2	
QX33/21	368	318	196	132	30	-	50	120	120	80	G 1 1/2" ¹⁾	G 3/4" ^{1) 2)}	G 1/2" ^{1) 2)}	
QX43/21	426	358	231	159	35	15	68	125	125	100	SAE 2"	SAE 1"	G 3/4" ^{1) 2)}	
QX43/31	441	373			33									
QX53/21	506	414	279	190	43	-	92	156	156	80	SAE 2 1/2"	SAE 1 1/4"	G 1/2" ^{1) 2)}	
QX53/31	521	429			39					15			100	G 3/4" ^{1) 2)}
QX53/41	559	467			287					197			32	23
QX63/31	591	499	337	234	47	14	92	195	197	100	SAE 3"	SAE 1 1/2"	G 3/4" ^{1) 2)}	
QX63/41	614	522			39	27				136			SAE 1"	
QX63/51	651	559			342	239				40			28	165
QX83/41	744	627	424	294	51	25	117	250	250	136	SAE 3 1/2"	SAE 2"	SAE 1"	
QX83/51	770	653			47	30				165			SAE 1 1/4"	
QX83/61	797	680			45	35				203			SAE 4"	SAE 1 1/2"

1) threaded port to DIN 3852, Part 2

2) pressure port to SAE J518 code 61 / ISO 6162-1 can be supplied for pressure ranges 2+3

H Double pumps QX.3/2

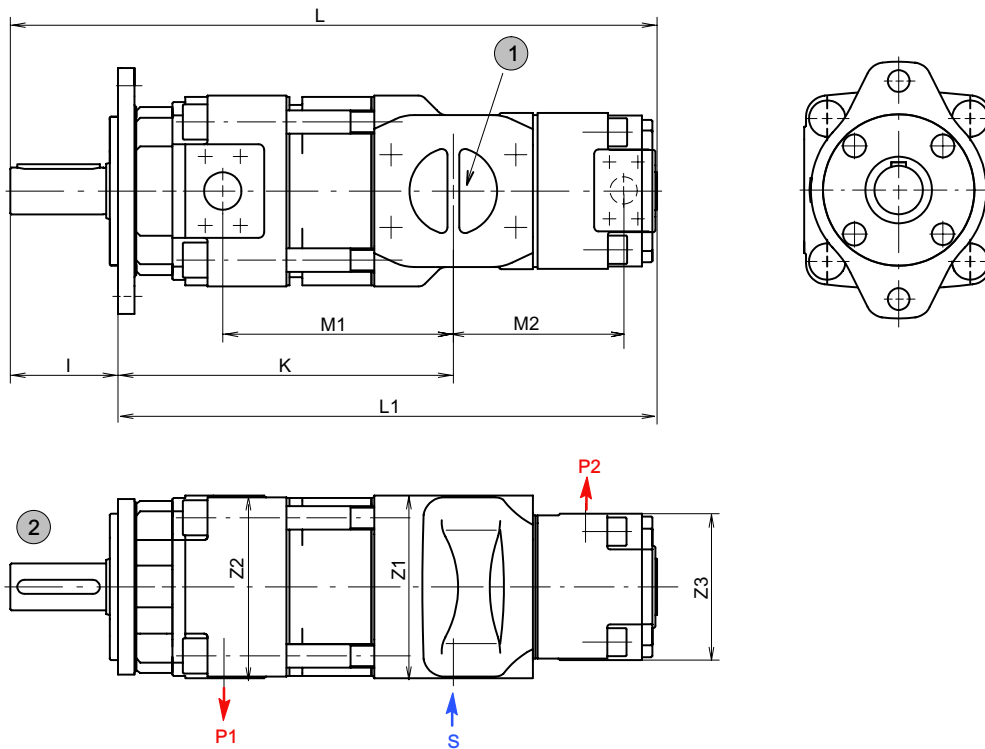

1 S = common suction port

2 shaft and mounting dimensions - see section 4

Typ	L	L1	K	M1	M2	I	Z1	Z2	Z3	S	P1	P2
QX23/22	295	250	158	102	67	45	100		100	G 1 1/4" ¹⁾	G 1/2" ^{1) 2)}	G 1/2" ^{1) 2)}
QX33/22	350	300	196	132	79	50	120		100	G 1 1/2" ¹⁾	G 3/4" ^{1) 2)}	G 3/4" ^{1) 2)}
QX33/32	363	313			87			120				
QX43/22	408	340	231	159	84	68	125		100	SAE 2"	SAE 1"	G 1/2" ^{1) 2)}
QX43/32	421	353			92			120	G 3/4" ^{1) 2)}			
QX43/42	453	385	238	167	111		125		125		SAE 1"	SAE 1"
QX53/22	488	396	279	190	92	92	156		100	SAE 2 1/2"	SAE 1 1/4"	G 1/2" ^{1) 2)}
QX53/32	500	408			100			120	G 3/4" ^{1) 2)}			
QX53/42	533	441	287	197	118			125		SAE 3"	SAE 1 1/4"	SAE 1"
QX53/52	553	461			127	156	SAE 1 1/4"					
QX63/32	571	479	337	234	112	92	195	197	120	SAE 3 1/2"	SAE 1 1/2"	G 3/4" ¹⁾
QX63/42	588	496			123				125			SAE 1"
QX63/52	619	527	342	239	137			156		SAE 3 1/2"	SAE 1 1/2"	SAE 1 1/4"
QX63/62	638	546			149	197	SAE 1 1/2"					
QX83/42	718	601	424	294	141	117	250		125	SAE 4"	SAE 2"	SAE 1"
QX83/52	738	621			150			156	SAE 1 1/4"			
QX83/62	757	640			162			197	SAE 1 1/2"			
QX83/82	789	672			179			250	SAE 2"			

1) threaded port to DIN 3852, Part 2

2) pressure port to SAE J518 code 61 / ISO 6162-1 can be supplied for pressure ranges 2+3

I Double pumps QX.3/3

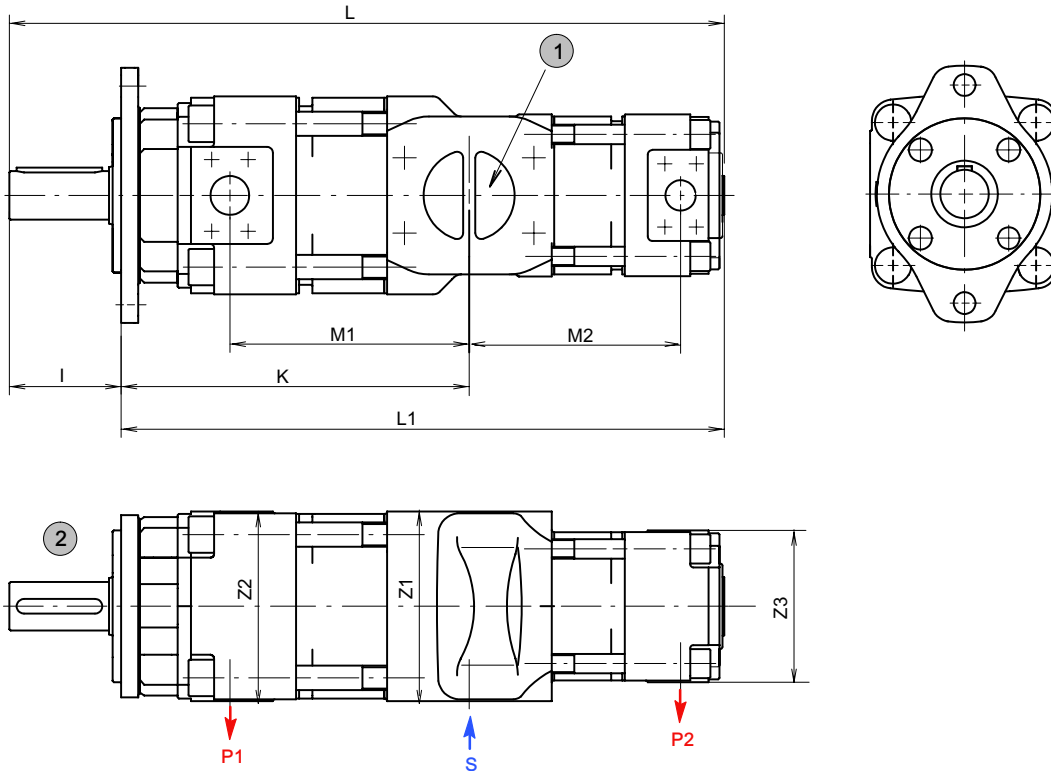

1 S = common suction port

2 shaft and mounting dimensions - see section 4

Typ	L	L1	K	M1	M2	I	Z1	Z2	Z3	S	P1	P2
QX23/23	330	285	158	102	102	45	100		100	G 1 1/4" ^{1) 2)}	G 1/2" ^{1) 2)}	G 1/2" ^{1) 2)}
QX33/23	385	335	196	132	114	50	120			G 1 1/2" ^{1) 2)}	G 3/4" ^{1) 2)}	G 3/4" ^{1) 2)}
QX33/33	408	358			132			120				
QX43/23	442	374	231	159	119	68	125		100	SAE 2"	SAE 1"	G 1/2" ^{1) 2)}
QX43/33	466	398			137			120	G 3/4" ¹⁾			
QX43/43	509	441			167			167	125			SAE 1"
QX53/23	523	431	279	190	127	92	156		100	SAE 2 1/2"	SAE 1 1/4"	G 1/2" ^{1) 2)}
QX53/33	546	454			145			120	G 3/4" ^{1) 2)}			
QX53/43	589	497	287	197	174			125				125
QX53/53	623	531			197	156	SAE 1 1/4"					
QX63/33	616	524	337	234	157	92	195	197	120	SAE 3 1/2"	SAE 1 1/2"	G 3/4" ^{1) 2)}
QX63/43	644	552			179				125			SAE 1"
QX63/53	689	597	342	239	207				156			
QX63/63	728	636			239	197	SAE 1 1/2"					
QX83/43	774	657	424	294	197	117	250		125	SAE 4"	SAE 2"	SAE 1"
QX83/53	808	691			220			156	SAE 1 1/4"			
QX83/63	847	730			252			197	SAE 1 1/2"			
QX83/83	904	787			294			250	SAE 2"			

1) threaded port to DIN 3852, Part 2

2) pressure port to SAE J518 code 61 / ISO 6162-1 can be supplied for pressure ranges 2+3

5.3 Ordering code for double pumps

		Q X 6 3 - 0 8 0 / 3 1 - 0 2 0 R * *
Series	= QX	
Frame size	= 2 / 3 / 4 / 5 / 6 / 8	
Pressure range	= 1 / 2 / 3	
Displacement [cm ³ /rev]	= 005 - 500	
	Frame size = 2 / 3 / 4 / 5 / 6 / 8	
	Pressure range = 1 / 2 / 3	
	Displacement [cm ³ /rev] = 005 - 500	
Rotation (viewed from shaft end)	right (CW) = R (standard) left (CCW) = L	
Option	see section 5.5	

Ordering example:

Required:	double pump
Pump 1	
Displacement:	80 cm ³ /rev
Continuous pressure:	300 bar
Type:	63-080
Pump 2	
Displacement:	20 cm ³ /rev
Continuous pressure:	160 bar
Type:	31-020
for use with mineral oil	
Ordering code:	QX63-080/31-020R

5.4 Standard configuration

- direction of rotation - right (CW)
- 2-hole mounting flange to ISO 3019/1 (SAE): sizes QX 3-6
- 2-hole mounting flange to ISO 3019/2 (metr.): sizes QX 2+8
- Nitrile seals
- parallel shaft end to ISO/R775
- Black priming, flange without priming

5.5 Options

- O = without priming
- 06 = external drain port in the pump rear cover
QX 2-5 = G1/4", QX 6 = G3/8", QX 8 = G1/2"
- 09 = Viton seals and without priming
- 12 = 2-hole mounting flange to ISO 3019/2 (metric): size QX 3-6
- 29 = for HFB and HFC fluids, frame sizes 2-5, without priming
- 66 = 4-hole mounting flange to ISO 3019/2 (metric)
- 83 = second suction port on:
QX61 = SAE 2", QX81 = SAE 2 1/2"
- 86 = for HFB and HFC fluids, frame sizes 6+8, without priming
- 117 = pressure port to SAE J518 code 61 / ISO 6162-1 can be supplied for frame size 2+3 with pressure ranges 2+3

Further options on request.

6 Triple pumps

The following table shows the triple-pump combinations that can be supplied (other triple-pumps on request). The individual pumps 1, 2 and 3 must be specified in accordance with the main characteristics shown in section 2.

The largest pump of the combination is situated at the shaft end and is referred to as Pump 1. For equal frame sizes, the pump with the larger displacement is situated at the drive side. Pumps 2 and 3 have a common suction port.

6.1 Selection table

Frame size of Pump 1

QX2.	QX3.	QX4.	QX5.	QX5.	QX6.	QX8.
QX21/21/21	QX31/21/21	QX41/21/21	QX51/22/23	QX52/52/31	QX61/31/33	QX81/42/23
QX21/21/22	QX31/21/22	QX41/21/23	QX51/23/23	QX52/52/42	QX61/41/21	QX82/42/43
QX21/21/23	QX31/21/23	QX41/22/22	QX52/23/23	QX52/52/43	QX61/41/42	QX82/51/53
QX21/22/22	QX31/22/22	QX41/23/23	QX53/22/22	QX52/52/52	QX61/42/23	QX83/51/53
QX21/22/23	QX31/22/23	QX42/22/22	QX51/31/33	QX52/52/53	QX61/42/43	QX81/61/61
QX21/23/23	QX31/23/22	QX43/22/22	QX51/33/33	QX52/53/31	QX61/43/43	QX81/62/63
QX22/22/22	QX31/23/23	QX43/23/22	QX51/41/23	QX52/53/53	QX62/41/22	QX81/63/33
QX22/22/23	QX32/22/22	QX43/23/23	QX51/41/42	QX53/53/23	QX62/42/42	QX82/61/61
QX23/23/23	QX32/22/23	QX41/31/33	QX51/41/43	QX53/53/33	QX62/43/43	QX82/62/62
	QX32/23/23	QX41/33/22	QX51/42/22		QX63/43/22	QX82/63/31
	QX33/21/22	QX41/33/33	QX51/42/43		QX61/52/53	QX83/61/61
	QX33/21/23	QX42/31/32	QX51/43/21		QX61/53/23	QX83/63/43
	QX33/23/23	QX42/32/32	QX51/43/22		QX61/53/31	QX83/63/61
	QX31/31/21	QX42/33/32	QX51/43/23		QX62/52/32	QX81/81/61
	QX31/31/22	QX43/31/31	QX51/43/43		QX62/52/52	QX81/81/81
	QX31/31/23	QX43/33/33	QX52/42/23		QX62/53/22	QX82/82/52
	QX31/31/31	QX41/41/33	QX52/42/42		QX62/53/23	QX82/82/62
	QX31/31/33	QX41/42/21	QX52/43/22		QX62/53/31	QX82/82/63
	QX31/32/22	QX41/42/23	QX52/43/23		QX62/53/33	QX83/83/53
	QX31/33/33	QX41/42/42	QX52/43/43		QX63/51/51	
	QX32/32/22	QX41/43/21	QX53/41/22		QX63/53/53	
	QX32/32/23	QX41/43/22	QX53/41/23		QX61/61/31	
	QX32/32/32	QX41/43/23	QX53/42/22		QX61/61/33	
	QX32/32/33	QX42/42/22	QX53/42/43		QX61/61/41	
	QX33/33/23	QX42/42/23	QX53/43/23		QX61/61/53	
	QX33/33/33	QX42/42/31	QX51/51/21*		QX61/62/42	
		QX42/42/32	QX51/51/32		QX61/62/63	
		QX42/42/33	QX51/51/33		QX61/63/32	
		QX42/42/42	QX51/52/32		QX61/63/33	
		QX42/42/43	QX51/52/33		QX61/63/41	
		QX43/43/43	QX51/52/42		QX61/63/42	
			QX51/52/43		QX62/62/33	
			QX51/53/22		QX62/62/43	
			QX51/53/23		QX62/62/53	
			QX51/53/31		QX62/62/62	
			QX51/53/33		QX62/62/63	
			QX51/53/41		QX62/63/63	
			QX51/53/43		QX63/63/32	
			QX51/53/52		QX63/63/43	
			QX52/52/23		QX63/63/53	
65	130	260	520	520	1050	2100

Max. permissible drive shaft torque [Nm]

* this pump is used as the ordering example in section 6.2

7 Low-flow capability pumps

7.1 General

The QX24 internal gear pump is a further development of the Bucher internal gear pump. With displacements from

3,3 to 8 cm³/rev, it extends the low-flow capability of the QX range.

7.2 Technical data

General characteristics	Unit	Description, value
Mounting attitude		unrestricted
Mounting method (standard)		oval 2-hole flange to ISO 3019/2 (metric)
Direction of rotation		right, alternatively left (but not reversible)
Pump drive method		in-line, by flexible coupling
Fluids		HLP mineral oils to DIN 51524, Part 2 HFC fluids to VDMA 24317 other fluids - consult Bucher Hydraulics GmbH
Maximum admissible level of contamination of the hydraulic fluid		NAS 1638, class 9 or ISO 4406, code 20/18/15
Operating viscosity	mm ² /s	20 ... 100 *
Starting viscosity		20 ... 300 * *other values on request
Fluid temperature	°C	HLP mineral oils min. -20, max.80. HFC 50 max. range for max. long life cycle +30 ... +60 (considering viscosity field)
Minimum inlet pressure	bar	0.85 absolute
Maximum pressure at drain port		1.5 absolute
External drain port		is always provided

7.3 Main characteristics

Effective displacement	Flow rate 1)	Maximum speed	Type	Maximum operating pressure at the pump outlet side				Torque	Power consumption
				continuous [bar]		Intermittent 2)			
[cm ³ /rev]	[l/min]	[rpm]		Mineraloil	HFC	Mineraloil	HFC	[Nm] 3)	[kW] 4)
3,3	4,8	3600	QX24-003	320	280	400	350	17	2,6
4,2	6,2	3600	QX24-004	320	280	400	350	21,5	3,2
5,1	7,4	3600	QX24-005	360	320	400	350	30	4,5
6,3	9,1	3600	QX24-006	360	320	400	350	36	5,5
8,0	11,5	3600	QX24-008	360	320	400	350	46	7,0



The main characteristics are valid for hydraulic oils as well as fire-resistant and environmentally-friendly fluids with a viscosity of 20 ... 50 mm²/s

1) at speed n = 1450 rpm (theoretical)

2) maximum intermittent pressure for max. 20 sec. but not more than 10% of the duty cycle

3) theoretical value at the max. permitted continuous pressure for mineral oil

4) theoretical value at the max. permitted continuous pressure for mineral oil at n = 1450 rpm

7.4 Volumetric efficiency (η)

measured at speed 1450 rpm; viscosity 42 mm²/s

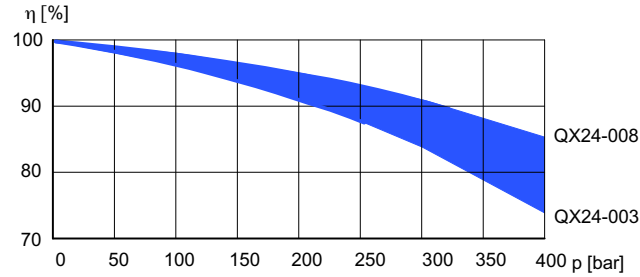

7.5 Single pumps

7.5.1 Dimensions

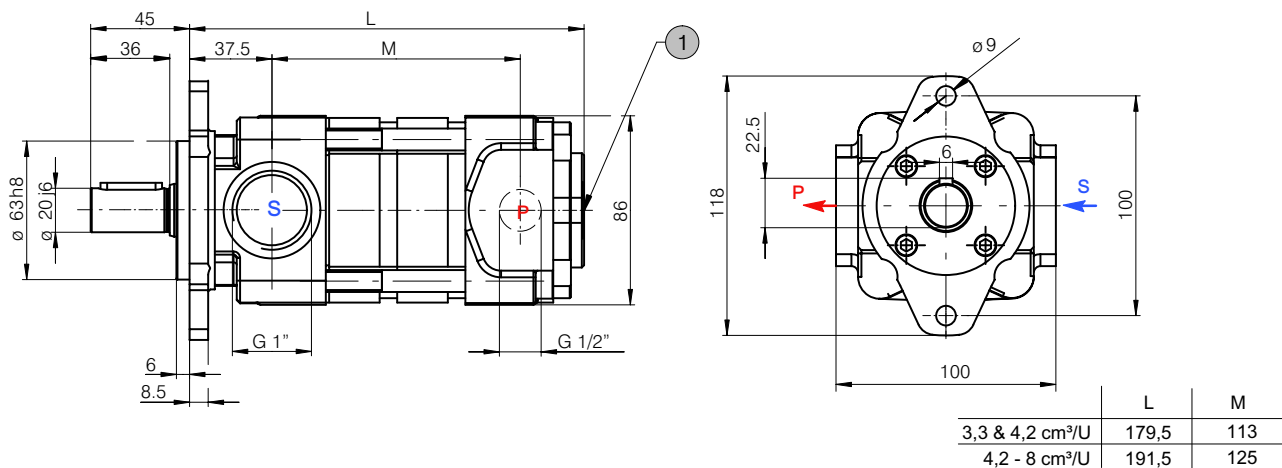

1 external drain port G1/4"

7.5.2 Ordering code

Series	= QX	Q	X							
Size	= 2			2						
Pressure range	= 4				4					
Displacement [cm ³ /rev]	= 003 - 008					0	0	4		
Direction of rotation (viewed from shaft end)	right (CW) = R left (CCW) = L								R	
Option	= External drain port									06

7.5.3 Standard configuration

- direction of rotation "right"
- 2-hole mounting flange to ISO 3019/2 (metric)
- nitrile seals
- cylindrical shaft end to ISO R775
- separate drain port G 1/4 in rear cover of the pump
- black priming, flange without priming

7.6 QX24 pumps combined with other QX-single pumps

7.6.1 Dimensions

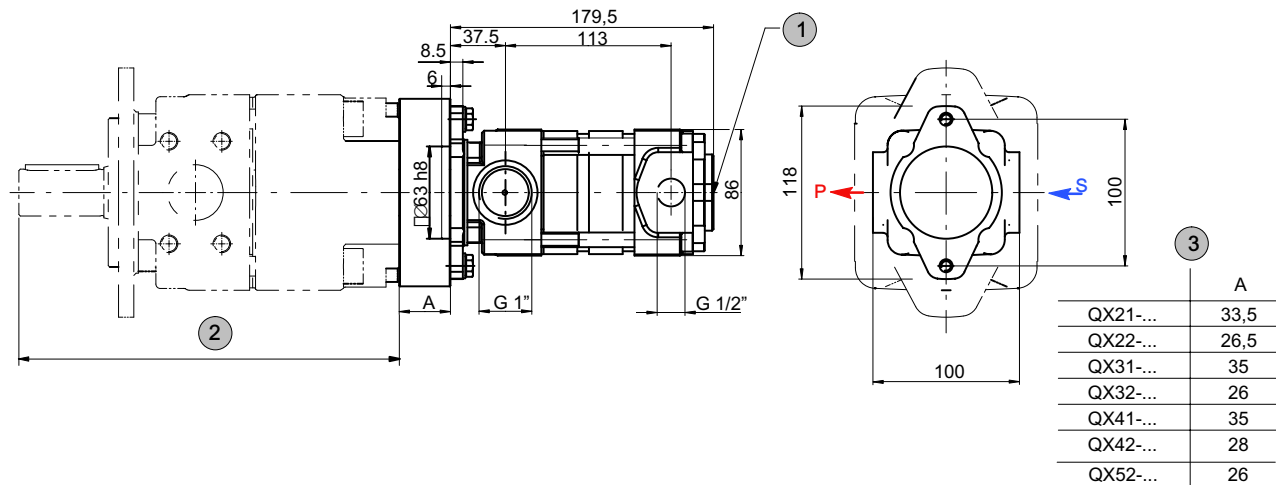

1	external drain port G 1/4"
2	dimensions see section 4

3	dimension A depends on the driving QX pump model (2)
---	--

7.6.2 Ordering code

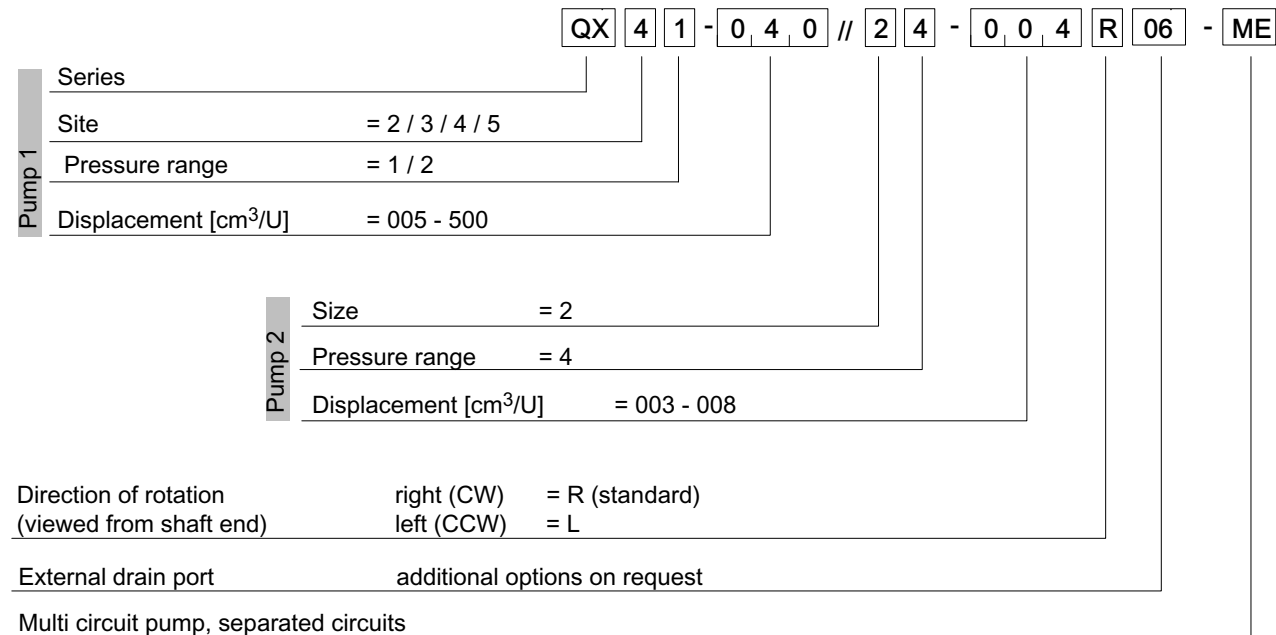

see section 4.7 for a selection

Ordering example:

Required:	Double pump	Pump 2	
Pump 1		Displacement:	4 cm ³ /rev
Displacement:	40 cm ³ /rev	Continuous pressure:	250 bar
Continuous pressure:	160 bar	Type:	24 - 004
Type:	41 - 040	For use with mineral oil:	
		Ordering code:	QX41-040//24-004R 06-ME

8 Fluid

QX pumps require fluid with a minimum cleanliness level of NAS 1638, Class 9 or ISO 4406, code 20/18/15.

HLP hydraulic oils to DIN 51524, Part 2, can be used without any special restriction as long as they remain within the specified temperature and viscosity ranges. HFC fire-resistant fluids to DIN 51502 can be used. Note that all fire-resistant fluids require special versions of the pumps or motors and must be approved by Bucher Hydraulics GmbH. We recommend the use of fluids that contain anti-wear additives for mixed-friction operating conditions. Fluids without appropriate additives can reduce the service life of pumps and motors. The user is responsible for maintaining, and regularly checking, the fluid quality. Bucher Hydraulics recommends a load capacity of $\geq 30 \text{ N/mm}^2$ to Brugger DIN 51347-2.

9 Fluid cleanliness class

Cleanliness class (RK) onto ISO 4406 and NAS 1638

Code ISO 4406	Number of particles / 100 ml			
	$\leq 4 \mu\text{m}$	$\leq 6 \mu\text{m}$	$\leq 14 \mu\text{m}$	NAS 1638
23/21/18	8000000	2000000	250000	12
22/20/18	4000000	1000000	250000	-
22/20/17	4000000	1000000	130000	11
22/20/16	4000000	1000000	64000	-
21/19/16	2000000	500000	64000	10
20/18/15	1000000	250000	32000	9
19/17/14	500000	130000	16000	8
18/16/13	250000	64000	8000	7
17/15/12	130000	32000	4000	6
16/14/12	64000	16000	4000	-
16/14/11	64000	16000	2000	5
15/13/10	32000	8000	1000	4
14/12/9	16000	4000	500	3
13/11/8	8000	2000	250	2

10 Operational reliability

To guarantee the reliable operation and a long service life of the pump, a maintenance schedule must be prepared for the power unit, machine or system. The maintenance schedule must make sure that the provided or permissible operating conditions of the pump are adhered to over the period of use.

In particular, compliance with the following operating parameters must be ensured:

- required oil cleanliness
- operating temperature range
- fluid level

Moreover, the pump and the system must be inspected at regular intervals for changes in the following parameters:

- Vibration
- Noise
- Differential temperature of pump – fluid in the tank
- Foaming in the tank
- Leak tightness

Changes in these parameters indicate wear of components (e.g. drive motor, coupling, pump, etc.). The cause must be immediately pinpointed and eliminated.

To provide high operational reliability of the pump in the machine or system, we recommend continuous, automatic checks of the above parameters and an automatic shut-down in the case of changes that exceed the usual fluctuations within the provided operating range.

11 Note

This catalogue is intended for users with specialist knowledge. The user must check the suitability of the equipment described here in in order to ensure that all of the conditions necessary for the safety and proper functioning of the system are fulfilled. If you have any doubts or questions concerning the use of these pumps, please consult Bucher Hydraulics GmbH.

12 Accessories

12.1 Bolt-on valves - SAE J518 code 61 / ISO 6162-1 pattern

Pressure relief valve A $\frac{S}{G}$ DF	Pressure relief valve solenoid control A $\frac{S}{G}$ DA	Accumulator charging valve AGSF
<p>Technical data sheet 100-P-000123</p>	<p>Technical data sheet 100-P-000119</p>	<p>Technical data sheet 100-P-0000124</p>

12.1.1 Examples for Bolt-on valves, mounted on QX Internal Gear Pumps

Bolt-on valve with threaded ports AGDF	Bolt-on valves with pipe flanges SAE ¹⁾ ASDF+RF	Bolt-on valve with pipe flanges SAE + RVSAE ²⁾ ASDF+RF+RVSAE+DPSAE+ZPSAE

1) Rohrflansche siehe Kapitel 7.3

1) Pipe flange see section 12.2

2) Please ask Bucher Hydraulics GmbH for check valves



IMPORTANT: For detailed informations on Bolt-on valves see www.bucherhydraulics.com

12.2 Pipe flanges - high pressure type (thread flange)

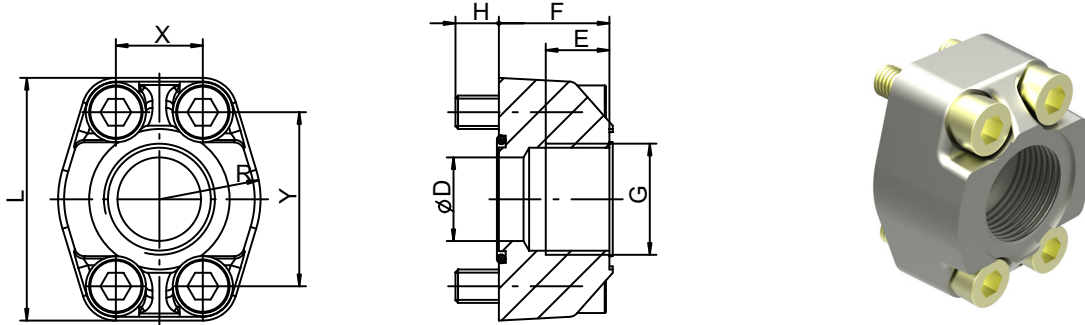

- Max. operating pressure 420 bar
- Flange size SAE J518 code 61 / ISO 6162-1

Threaded pipe flanges are spot-faced for DIN 2353 pipe fittings
Material: ST37 / for Viton seals, contact Bucher Hydraulics GmbH

Ordering-number	Ordering code	Size	DØ	E	F	H	L	R	X	Y	Viton seal 90 Shore A	Retaining screws DIN912-12.9 / [Nm]	
100037000	RF 01-R08	G 1/2"	12,5	16	27	13	54	23	17,5	38	20,24x2,62	M8x30	30
100037010	RF 02-R10	G 3/4"	20	18	30	12	65	26	22,2	47,6	26,65x2,62	M10x30	60
100037020	RF 03-R11	G 1"	25	20	34	13	70	29	26,2	52,4	32,99x2,62	M10x35	60
100037030	RF 04-R12	G 1 1/4"	32	22	38	14	80	36	30,2	58,6	40,86x3,53	M10x40	60
100037040	RF 05-R13	G 1 1/2"	38	24	41	19	94	41	35,7	70	44,04x3,53	M12x45	120
100037050	RF 06-R14	G 2"	50	26	45	20	102	48	42,9	77,8	59,92x3,53	M12x50	120
100055470*	RF 07-R16	G 2 1/2" *	63	30	50	18	114	57	50,8	89	72,62x3,53	M12x45	120

* at RF07 only to 210 bar be allowed

12.3 Pipe flanges - low pressure type (welding flange)

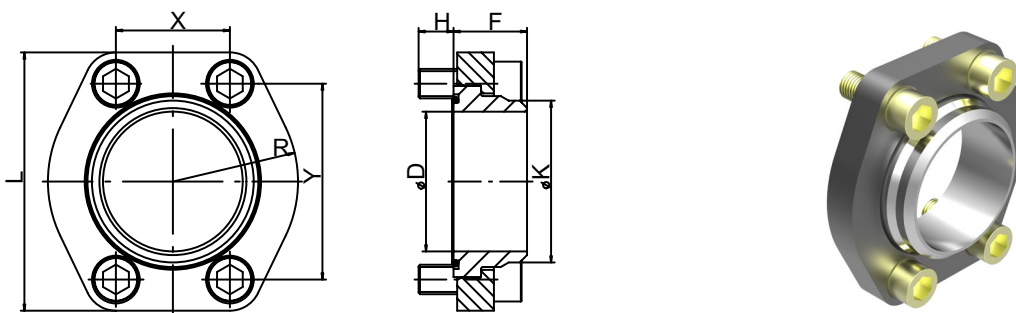

- Max. operating pressure 16 bar
- Flange size SAE J518 code 61 / ISO 6162-1

Material: HST37 / for Viton seals, contact Bucher Hydraulics GmbH

Ordering number	Ordering code	SAE flange Size	D	K	F	H	L	R	X	Y	Viton seal 90 Shore 'A'	Retaining screws DIN 912-8.8 Torque [Nm]		pipe ¹⁾ O/dia. approx.
100062450	RN 07-S	2 1/2"	63	75	35	14	120	57	51	89	69,44x3,53	M12 x 30	70	75
100063880	RN 08-S	3"	76	88			140,5	68	62	106,5	85,32x3,53	M16 x 40	180	88
100063890	RN 09-S	3 1/2"	89	100	40	19	158,5	73	70	120,3	98,02x3,53	M16 x 40	180	100
100063900	RN 10-S	4"	103	115			168	79	78	130	110,72x3,53	M16 x 40	180	115

1) We recommend the use of seamless precision steel tube to DIN 2391 with wallthick. max 6 mm

mail

web

cop

All rights reserved.

Data is provided for the purpose of product description only, and must not be construed as warranted characteristics in the legal sense. The information does not relieve users from the duty of conducting their own evaluations and tests. Because the products are subject to continual improvement, we reserve the right to amend the product specifications contained in this catalogue.

Classification: 410.100. 000